

# Sun Shade

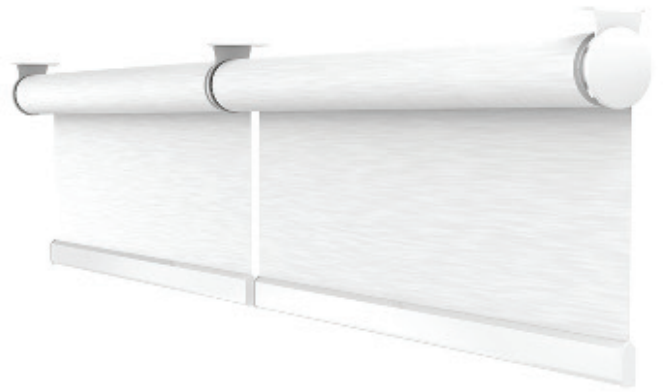

## Coupled Shade

Installation

**Nice**

# Coupled Shade Installation

## Tools Needed

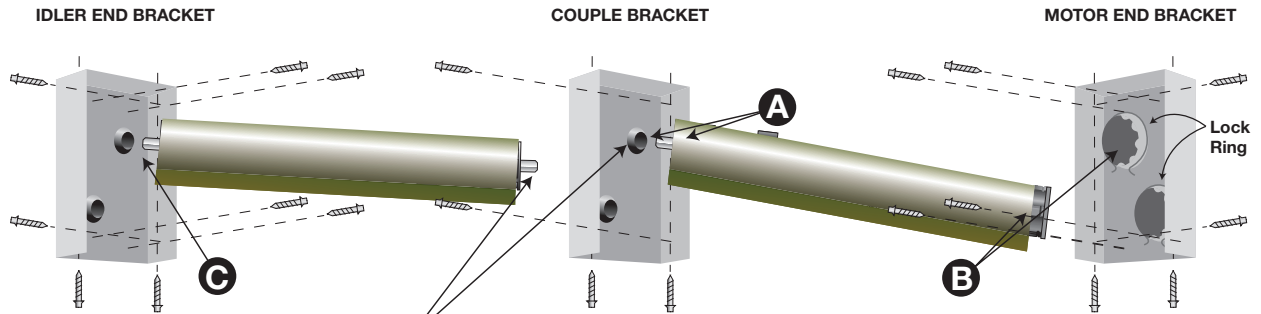
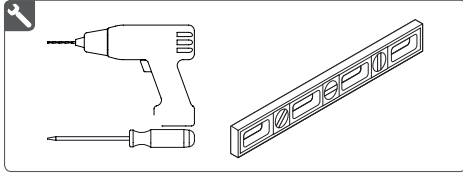

- A.** Insert the coupled end of Motorized Shade.
- B.** Insert the Motor End. Remove the lock ring prior to inserting Motor End of shade. Re-install the lock ring after the shade is fully assembled into bracket.
- C.** Insert the Idler End of coupled shade.
- D.** Insert the coupled end of Coupled Shade. Mate the pin of this end into the pin of the opposing shade. The pins are male/female.

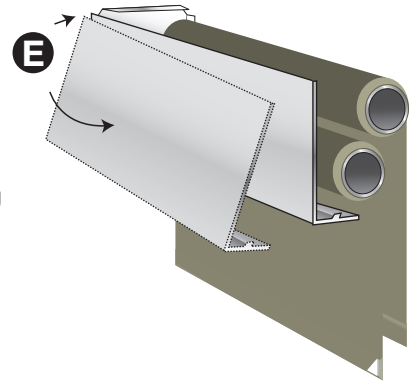

Test by running the shade system up and down. If the hem bars are not lined up, follow the *Leveling Hem Bar* steps below to align them.

- E.** Snap on Fascia Panel. Hook fascia to top of brackets, then snap in the bottom edge.

## Coupler Assembly - Leveling Hem Bars

To level the coupled shade hem bar with the motorized shade hem bar, follow the below steps:

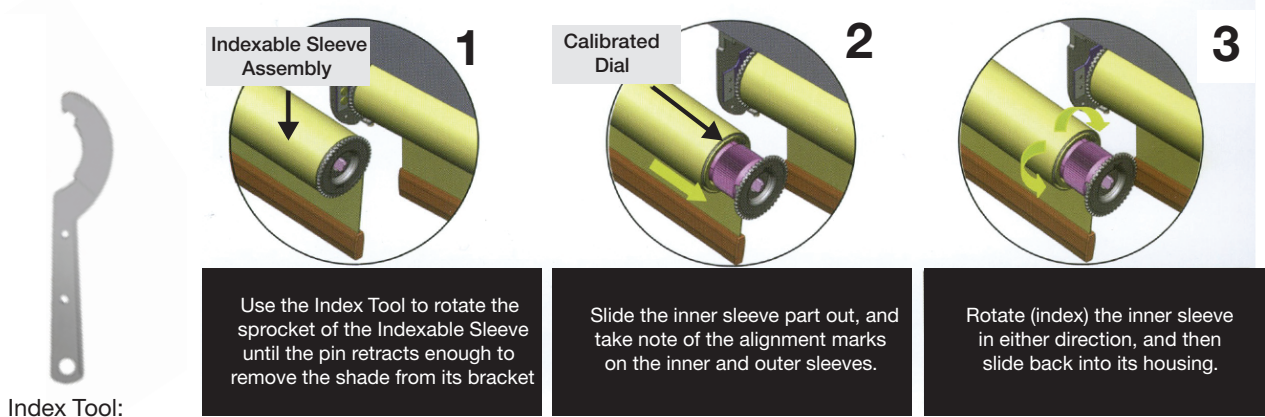

Index Tool:

- 4** Re-align the pin of the Indexable Sleeve assembly with the bearing/hole in the bracket. Use the Index Tool to rotate the sprocket so that the pin extracts itself once again from the Indexable Sleeve assembly and locks with the female pin of the mating roller.

**NOTE:** If you lack an indexing tool, you can also easily use your fingers to rotate the sprocket dial.

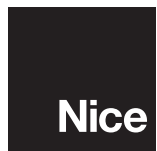

Niceforyou.com

©2023 Nice North America LLC.  
All rights reserved.

**Technical Support:**  
800-421-1587

**Technical Support Hours:**  
M - F, 6am - 4pm PST

**Nice North America**  
c/o Customer Service  
5919 Sea Otter Place, Ste. 100  
Carlsbad, CA 92010