

Pro-GT



Automation for industrial sectional overhead doors

Instructions and warnings for installation and use

Nice

Contents

Warranty	3	NICE N-4 Photocell (MK00650)	27
Verification of Operator and Hardware	4	Wall installation	27
PRO-GT Specifications	5	For Nice Nema-1 photobeams:	28
Important Safety Instructions	6	FRABA N-4/4 Thru-Beam Photocell (MK00697)	29
Important Installation Instructions	6	Clutch Adjustment	30
Installation Instructions	7	Brake Adjustment	30
Preparation	8	Emergency Manual Operation	31
Wall Mounting Bracket and Operator Installation	9	Operator Maintenance	32
Electrical Connections	11	Trolley Operator Pro-GT Diagram	33
SECTION A: PRO-GT	12	Trolley Operator Pro-GT Parts List	34
Connection of Power Supply and Control Station	12	MS100-WW 1-Phase Wiring Diagram	36
Limit Switch Adjustment	12	MS100-IM-WW 1-Phase Wiring Diagram	37
Connection of a Reversing Edge Device and Control Accessories	13	MSL100-110V-WW 1-Phase Wiring Diagram	38
SECTION B: PRO-GT Relay Logic Controls with Interface Module	14	MSL100-220V-WW 1-Phase Wiring Diagram	39
Connection of Power Supply and Control Station	14	MSLC100-WW 1-Phase Wiring Diagram	40
Operator Electrical Connections and Start-up Instructions	14	MS300-WW 3-phase Wiring Diagram	41
SECTION C: PRO-GT(E): Full Feature Logic Board Smart 10.0	17	MS300-IM-WW 3-Phase Wiring Diagram	42
Connection of External Single-Button Device	19	MSL300-WW 3-Phase Wiring Diagram	43
Modes of Operation	19		
Programming Instructions	21		
Run-Timer Setup	21		
Mid-Stop Setup	22		
Timer to Close Setup	22		
Delay on Close Setup (only for use with optional apartment board)	22		
On-Board Receiver Programming	22		
Installing the Antenna	22		
Programming the On-Board Radio Receiver	23		
Operation	23		
To Erase all Learned Transmitters	23		
Replacing Remote Control Batteries	23		
Dip-Switch Setup	24		
Status LED	24		
SECTION D: For all Operator Control Types	25		
Limit Switch Adjustment	25		
SECTION E: For Operators with Interface Modules or Logic boards	26		
Installation of Nice N-1 or N-4 Photocells	26		
Installation Safety Precautions	26		
Wall installations	26		

Warranty

NICE NORTH AMERICA warrants that materials and workmanship are free from defects for a period of four (4) years or 100,000 cycles, whichever comes first. The start of the warranty will be determined by the date of invoice. Materials returned to Nice deemed defective after examination will be returned at the option of Nice with repaired, new, or re-manufactured parts.

NICE NORTH AMERICA will not be responsible for any charges incurred in the process of returning defective material. All returned material must be received pre-paid, or it will not be accepted.

This warranty is limited, and in lieu of all other warranties expressed or implied. There is no expressed liability due on the part of the seller.

MP00041-44	#40 Drive Chain
*	#50 reduction chain and sprockets
MP00045	Cast-iron Pillow block bearings on drive
PRO-GTW__	Waterproof Modification
PRO-GT4X__	Corrosion Proof Modification
PRO-GTX__	Explosion Proof Modification
MP00007*	115 Volt Control Circuit
MP00061**	1.5 Sec Time Delay on Reverse
MP00001**	Timer to Close
PRO-PL	Separate Control Panel
MP00036	Trolley hoist Disconnect
MP00030,78-80	Dual Trolley Assembly
MP00035	Minimum Depth modification

* Not available for logic board controls

** Standard feature with logic board controls

WARNING





DO NOT CONNECT TO ELECTRICAL POWER DURING
INSTALLATION OR SERVICING OF OPERATOR.

IMPORTANT

FOR ANY QUESTIONS CONCERNING THE SAFETY OR OPERATION OF THIS OPERATOR PLEASE CONTACT NICE AT 1-877-888-1116. SAVE THESE INSTRUCTIONS

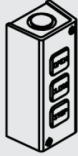
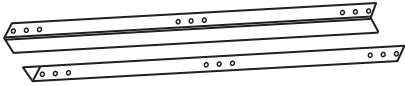
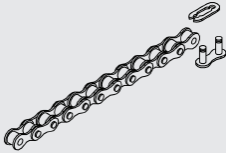
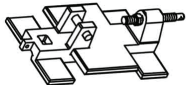
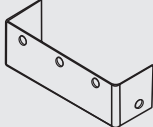
Verification of Operator and Hardware

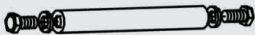
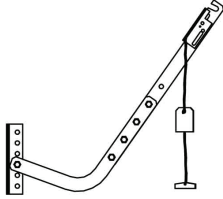
Upon delivery of your Nice heavy-duty trolley door operator, please inspect the unit carefully for damage. Verify that operator horsepower, voltage, phase and amperage correspond to available power supply and door application. Check that along with your operator you have received the following standard hardware.

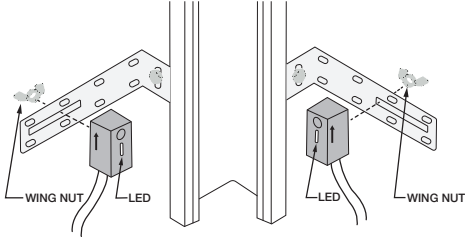
1 x OPEN /CLOSE/STOP 3-button control station	
1 x Set of trolley tracks (door height + 2'6")	
1 x Drive chain package (door height x 2 + 5' 6" (1.65m) c/w connecting link	
1 x Trolley carriage and 3/8 take-up bolt assembly	
1 x Trolley track end bracket	
1 x Front idler	
2 x Trolley spreader bars	
1 x Trolley arm assembly	
1 x Warning sign	
1 set of Nice photocells (supplied when operator ordered with interface module or logic board controls)	

PRO-GT Specifications

PRO-GT heavy-duty gearhead trolley operator is designed for standard lift overhead sectional garage doors.

Standard Operator Weight	95-150 Lbs				
Motor					
• Horsepower	1/2 HP	3/4 HP	1 HP	1.5 HP	2 HP (3-phase only)
•	Continuous duty 1725 RPM industrial type motor. Full overload protection.				
•	Built-in overload protection (3-phase) or separate full overload protection (1-phase)				
• Voltage	115V 1-phase (60Hz)	230V 3-phase (60 Hz)	220V 1-phase (50Hz)		
	230V 1-phase (60Hz)	460V 3-phase (60Hz)	380V 3-phase (50Hz)		
	575V 3-phase (60Hz)				
Reduction	Primary: Heavy duty worm gear reducer 20:1 (standard) or 40:1 reduction Secondary : #41 chain and sprockets				
Output Shaft Speed	86 RPM				
Door Speed	10"/second				
Brake	Solenoid actuated drum and brake shoe braking system to prevent coasting and maintain door position.				
Wiring Type (3 Options)	<p>Option 1: Full Feature logic board Smart 10.0 (UL325 (2010) compliant). NOTE: Nice compatible primary entrapment device must be connected for B2, T or TS (momentary or timer activation on close) feature.</p> <p>Option 2: Relay logic controls with Interface Module (UL325 (2010) compliant). C2 Standard factory wiring (constant pressure on close, momentary contact on open and stop). If momentary contact on close (B2) wiring is desired, move "white" wire from terminal #6 to terminal #3. NOTE: Nice compatible primary entrapment device must be connected for B2 (momentary activation on close) or for T (timer to close) feature.</p> <p>Option 3: Standard relay logic controls (not UL325 (2010) compliant, not available in US) C-2 Wiring constant pressure on close, momentary contact on open and stop. NOTE: If momentary contact on close (B2) wiring is desired, move "white" wire from terminal #5 to terminal #3.</p>				
Transformer	24VAC control circuit, supplies power to drive control relays with 15VA power available for external devices.				
Limit Adjustment	4 micro switches that control door travel. These limit switches are activated by fully adjustable screw type cams.				
Emergency Disconnect	Quick release disconnect door arm to allow person to disengage operator drive chain from door for manual operation.				
Clutch	Adjustable in-line friction clutch to minimize damage to door operator, door or vehicles.				

Other Dimensions:

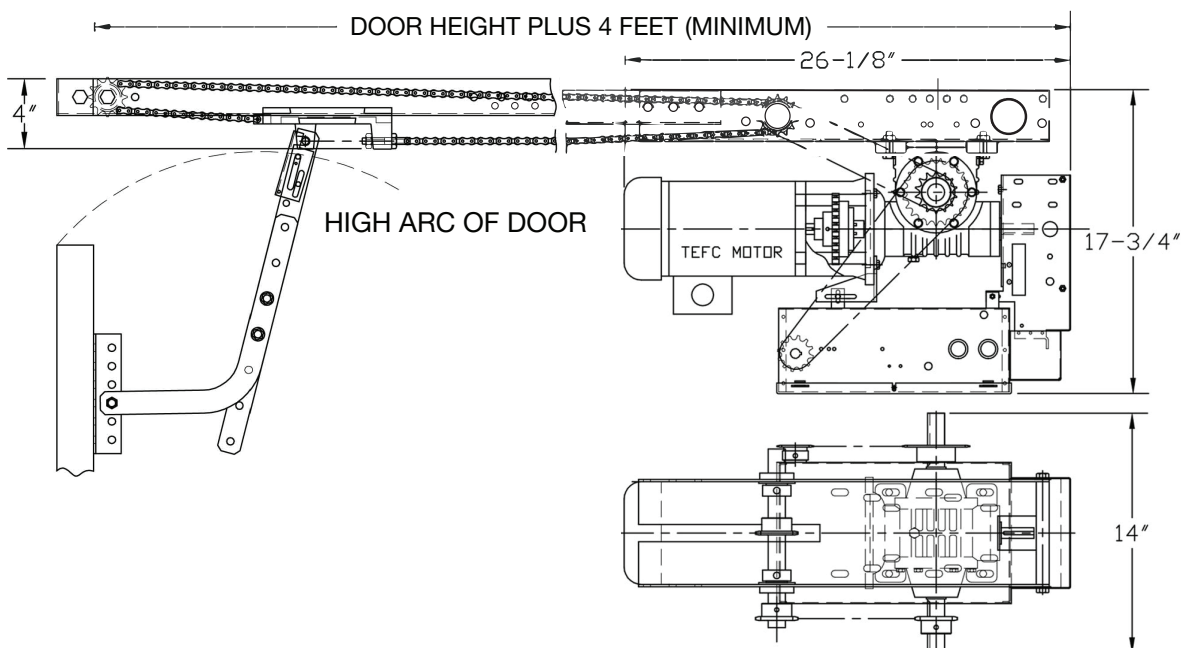

Important Safety Instructions

WARNING

TO REDUCE THE RISK OF INJURY OR DEATH:

- READ AND FOLLOW ALL INSTRUCTIONS
- Never allow children to operate or play with door controls. Keep the remote control (where provided) away from children.
- Personnel should keep away from a door in motion and keep the moving door in sight until it is completely closed or opened. **NO ONE SHOULD CROSS THE PATH OF A MOVING DOOR.**
- Test the door's safety features at least once a month. After adjusting the limit of travel, retest the door operator's safety features. Failure to adjust the operator properly may cause severe injury or death.
- For products having a manual release, if possible, use the manual release only when the door is closed. Use caution when using this release when the door is open. Weak or broken springs may cause the door to fall rapidly, causing severe injury or death.
- **KEEP DOORS PROPERLY OPERATING AND BALANCED.** See Door Manufacturer's Owner's Manual. An improperly operating or balanced door could cause severe injury or death. Have trained door systems technician make repairs to cables, spring assemblies, and other hardware.
- Press the "OPEN" device or use emergency disconnect mechanism if a person is trapped under the door.
- **SAVE THESE INSTRUCTIONS.** The owner or users must understand the safety and operation of door system. Insure that this installation manual be located close to the door system.

Important Installation Instructions

- READ AND FOLLOW ALL INSTALLATION INSTRUCTIONS
- Commercial door operators are never to be installed on a residential installation
- Install only on a properly operating and balanced door. A door that is operating improperly could cause severe injury. Have qualified service personnel make repairs to cables, spring assemblies, and other hardware before installing the operator.
- Remove all pull ropes and remove, or make inoperative, all locks (unless mechanically and/or electrically interlocked to the power unit) that are connected to the door before installing the operator.
- Install the door operator at least 8 feet or more above the floor if the operator has exposed moving parts.
- Do not connect the operator to the source of power until instructed to do so.
- Locate the control station: (a) within sight of the door, (b) at a minimum height of 5 feet so that small children cannot reach it, and (c) away from all moving parts of the door.
- Install the Entrapment Warning Placard next to the control station in a prominent location.
- For products having a manual release, instruct the end user on the operation of the manual release.
- Install non-contact entrapment protection devices (photocells) and/or contact entrapment protection devices (reversing edges). **NOTE:** photocells should be installed at no more than 6" from the floor. Edges should be installed on the leading edge of the door.

Installation Instructions

⚠ WARNING ⚠

DO NOT INSTALL THIS OPERATOR BEFORE READING THIS MANUAL CAREFULLY.

NOTE:

- Installation of operator must be done by a qualified installer. Door must be properly installed and working smoothly. Remove all door locks prior to installation.
1. Install control station away from all moving door parts, within sight of the door and a minimum of 5 ft (1.5 m) from the ground.
 2. Install entrapment warning sign next to control station.



3. Do not remove emergency release tag attached to disconnect handle.

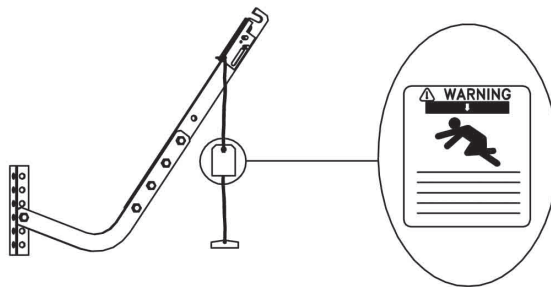

Preparation

1. Lay out operator and trolley tracks on ground in front of door with door operator motor facing away from door.
2. Install track spacers evenly to track assembly.
3. Install 3/8" take-up bolt to carriage using two 3/8" hex nuts and lock washer provided.
4. Slide trolley carriage through end of tracks towards operator with take-up bolt facing operator.
5. Install front idler assembly to the second set of holes end of trolley tracks.
6. Bolt the rail assembly to the operator frame using the four 3/8" x 3/4" bolts and the 3/8" serrated hex nuts provided.

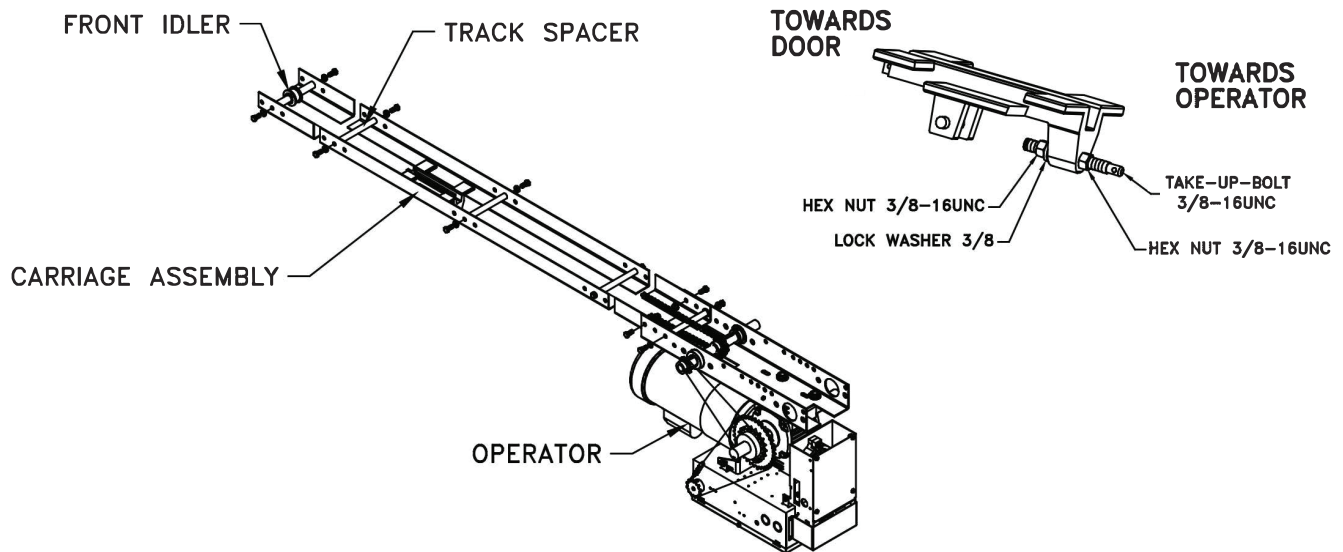

7. Attach one end of drive chain to carriage using connecting link provided. Run chain around front idler, over the track spacers, around drive sprocket and connect to take-up-bolt using connecting link provided. Adjust take-up-bolt so that chain sags approximately 3" (7.5 cm) at midpoint of tracks. Remove links from drive chain if necessary to make proper adjustment.

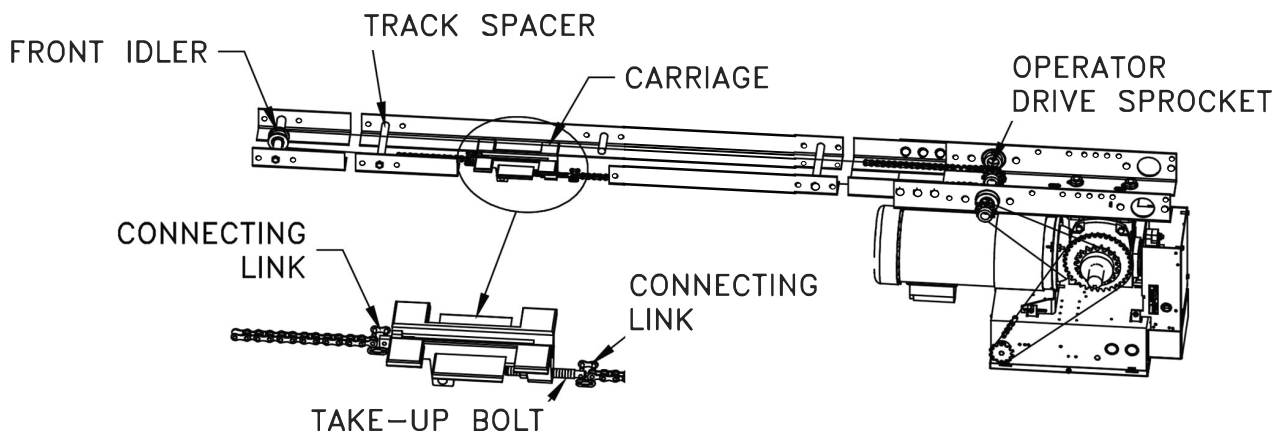

Wall Mounting Bracket and Operator Installation

NOTE : Trolley type operators should generally be mounted directly over the center of the door and the trolley tracks should clear the tracks by 2-1/2" (6.5 cm). However, if interfering structures or other reasons do not allow for centered mounting, it is possible to install it up to 18" off-center for torsion spring doors.

1. Locate the center of door by measuring door width and mark a vertical line above the door.
2. Determine the highest point of door travel by manually opening the door. Using a carpenter's level, project a line from where the top section of door reaches its highest point. Mark the spot where this line (high arc) intersects with the vertical line drawn earlier.

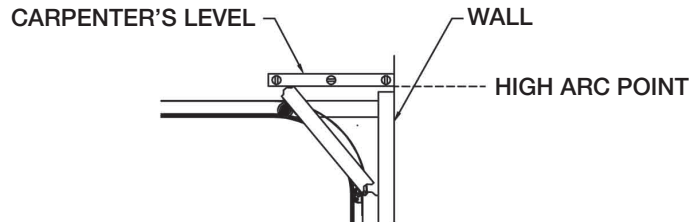

3. Mount a wood block or angle iron to the wall above the door opening as shown below. The wall mounting bracket has 3 holes for anchoring to wood block or angle iron. Bracket should be centered with door and positioned so that these holes are 2-1/2" (6.5 cm) above the high arc line of door. Secure wall mounting bracket using suitable hardware.

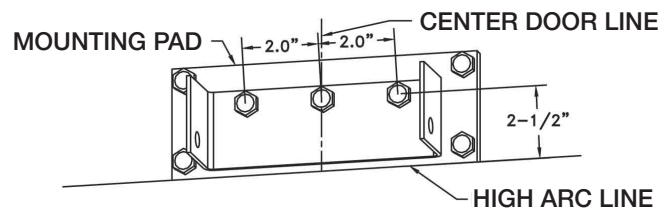

4. While allowing motor to rest on floor, raise front end of track assembly and secure (but not tighten) to wall mounting brackets with 3/8" bolts and nuts provided.

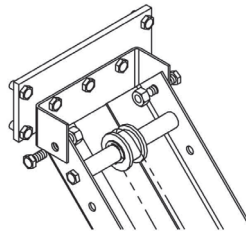

5. Swing the operator and track assembly above the level of the door tracks and temporarily secure in place with rope or chain. Carefully open door. Align operator and rails with center of door. Using the door as support, shim the operator so that there is 3" (7.5cm) clearance between door and bottom of operator. Tighten wall mounting bracket bolts.

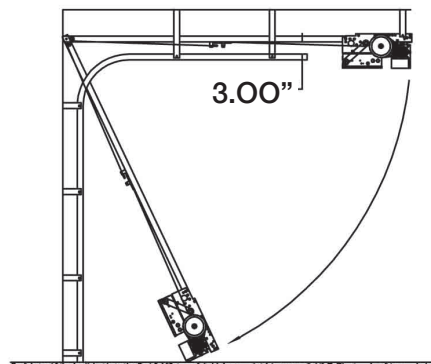

- Install hanging brackets (braces) from ceiling or structure to any of the five 3/8" holes located on operator frame. For tracks over 14' long it is recommended to install braces to the tracks at 4' (1.2m) to 5' (1.5m) from operator.

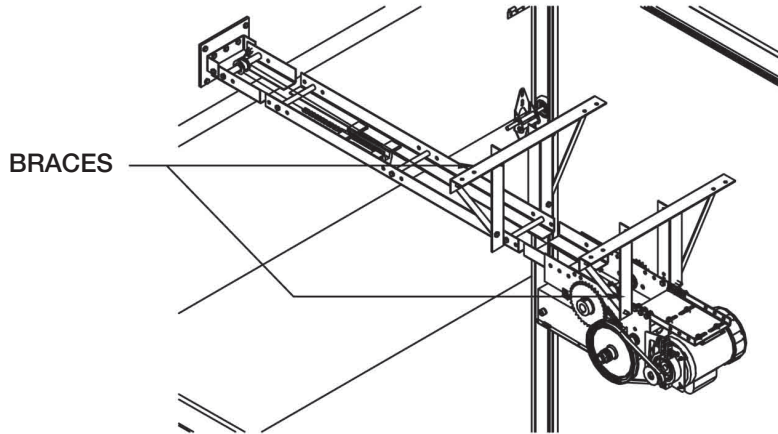

TROLLEY ARM INSTALLATION

- Manually close door to fully closed position. Slide trolley carriage towards front idler and latch trolley arm to carriage spring pin by pulling on rope. When installed the open side of notch should face the door.
- Using 3/8" bolts and nuts provided, align the mounting holes of straight arm and curved arm so that pivot bolt on door bracket is in line with the top rollers of the door. Align door bracket with centerline of door and secure to door using suitable hardware.

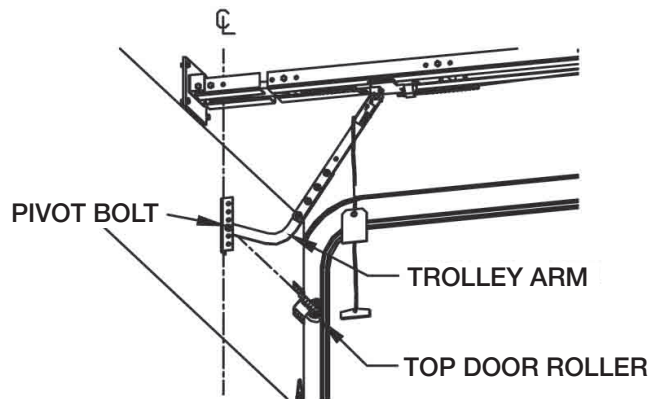

- When properly installed the door arm should lean slightly away from door when door is fully closed.

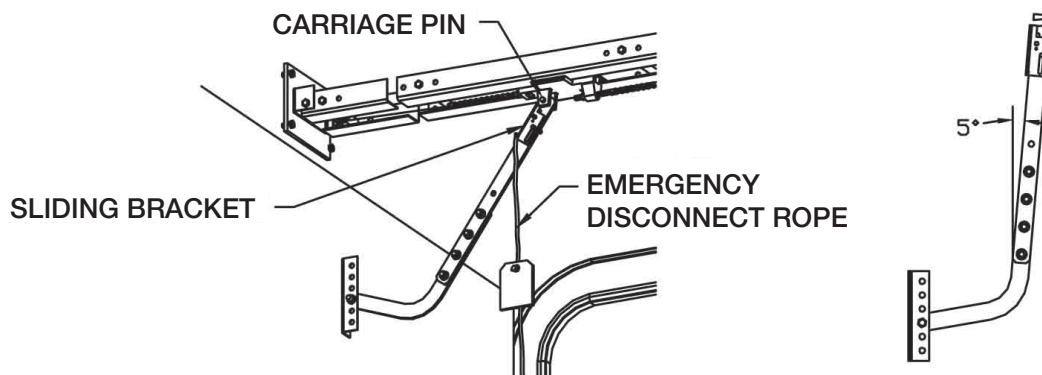

- At this time, check all bolts for tightness.

Electrical Connections

These are 3 possible electrical control configurations for this operator:

- A) Standard relay logic controls (not UL325 (2010) compliant, not available in US or Canada). Refer to Section A for electrical connections. Refer to electrical drawings inside your operator control box or generic drawings MS100-WW or MS300-WW in the electrical drawings section at the end of this manual.
- B) Relay logic controls with Interface Module (UL325 (2010) compliant). Refer to Section B for electrical connections. Refer to electrical drawings inside your operator control box or generic drawings MS100-IM-WW or MS300-IM-WW in the electrical drawings section at the end of this manual.
- C) Full Feature logic board Smart 10.0 (UL325 (2010) compliant). Refer to Section C for electrical Connections and logic board instructions. Refer to electrical drawings inside your operator control box or generic drawings MSL100-110V-WW, MSL100-220V-WW, MSLC100-WW, MSL300-WW or MSLC300-WW in the electrical drawings section at the end of this manual.

IMPORTANT

- EACH INDIVIDUAL COMMERCIAL DOOR OPERATOR MUST HAVE IT'S OWN DEDICATED POWER SUPPLY
- NICE HIGHLY RECOMMENDS THAT EACH INDIVIDUAL COMMERCIAL DOOR OPERATOR HAVE AN EXTERNAL CIRCUIT BREAKER OR FUSED DISCONNECT

⚠ WARNING ⚠

COMPARE AVAILABLE POWER SUPPLY VOLTAGE TO OPERATOR NAMEPLATE PRIOR TO ELECTRICAL CONNECTION. FAILURE TO CONNECT APPROPRIATE POWER SUPPLY VOLTAGE MAY CAUSE SERIOUS DAMAGE TO OPERATOR.

Refer to electrical diagrams inside control box cover or at the end of this manual prior to connection of power supply or control station.

⚠ WARNING ⚠

TO REDUCE THE RISK OF INJURY OR DEATH:
ALL ELECTRICAL CONNECTIONS SHOULD BE MADE BY A QUALIFIED SERVICE PERSON
DO NOT ATTEMPT TO MAKE ELECTRICAL CONNECTIONS TO OPERATOR UNLESS POWER SUPPLY HAS BEEN DISCONNECTED AT FUSE BOX.
OPERATOR MUST BE CONNECTED IN ACCORDANCE TO LOCAL ELECTRICAL CODES AND GROUNDED TO GREEN GROUND LUG LOCATED INSIDE CONTROL BOX.

SECTION A: PRO-GT

Standard relay logic controls (not UL325 (2010) compliant, not available in US or Canada)

Connection of Power Supply and Control Station

Power Wiring: Use 1-1/8" (2.85 cm) diameter holes for all power wiring.

1. **Single Phase:** Connect single phase power supply to terminals L/L1 (line) and N/L2 on three-pole power terminal strip.
2. **Three Phase:** Connect three phase power supply to terminals L1, L2 and L3 on three-pole power terminal strip.

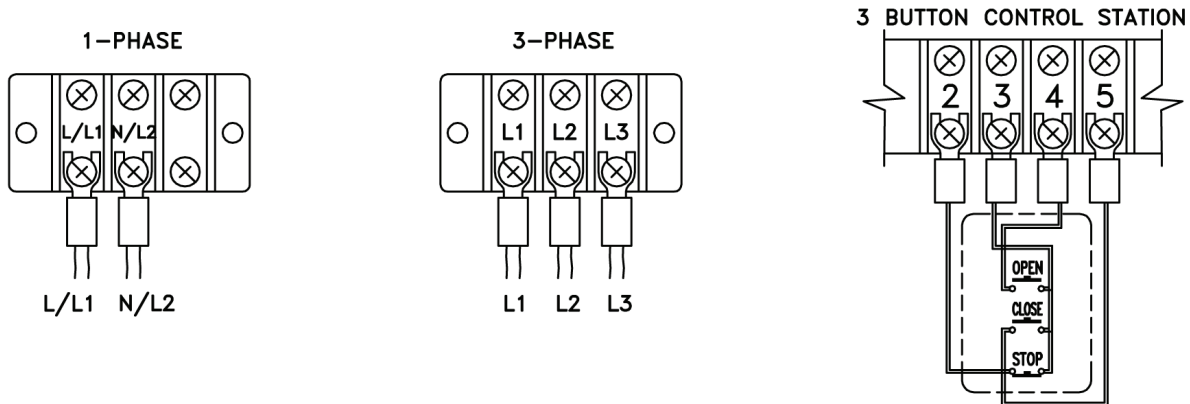

CONTROL WIRING: Use 7/8" (2.22 cm) diameter holes for all control wiring.

NOTE: Do not run control wires and power wires in same conduit.

- Install control station within clear sight of door but away from all moving parts of door or hardware. Install Entrapment warning sign next to control station. Connect 3-button (open/close/stop) push button station to terminals 2, 3, 4 and 5. Refer to electrical diagram for connection of two 3-button stations.

NOTE: After electrical connections are made, manually move door to mid-position and, using the control station press the "Open" button for several seconds and then press the "Stop" button. If door did not move in correct direction verify wiring control station. For 3-phase operators, if door still moves in wrong direction reverse any two of the three incoming power supply leads to correct rotation.

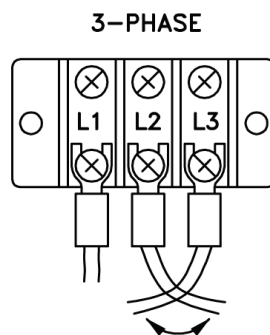

Limit Switch Adjustment

See Limit Switch Adjustment, page 25.

Connection of a Reversing Edge Device and Control Accessories

1. **Reversing Edge device (must be normally open contact):**

NOTE: If the door is controlled by any device or wired in such a manner that the door is not controlled by constant pressure on close then an appropriate reversing edge must be installed.

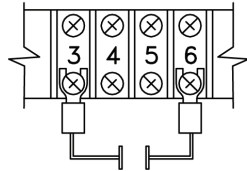

2. **External interlock:** Remove jumper between terminals 1 and 2 and wire a N.C. interlock contact between these two terminals.

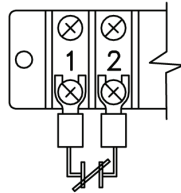

3. **Radio control receiver:** Wire standard radio receiver to separate radio strip on side of control box or to terminals 7, 8 and 9 on control terminal strip inside control box.

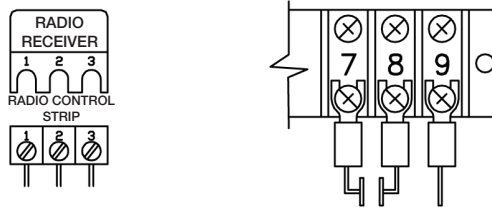

4. **Single button open/close device:** Wire to terminals 7 and 8 on control terminal strip.

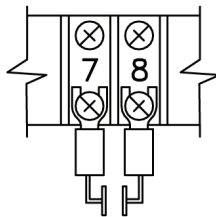

5. **Loop detectors, standard photocells (with a N.O. contact) and other reversing devices:** Wire to terminals 3 and 6 on control terminal strip.

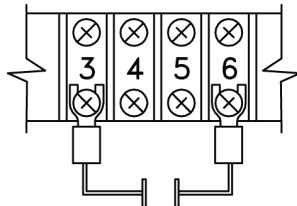

6. **24 Volt power:** Wire to terminals 1 and 9 on control terminal strip.

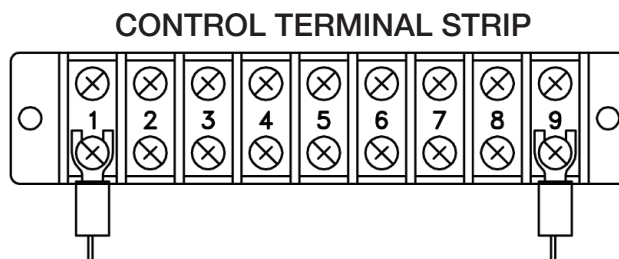

SECTION B: PRO-GT Relay Logic Controls with Interface Module

[UL325 (2010) Compliant]

Connection of Power Supply and Control Station

Operator Electrical Connections and Start-up Instructions

NOTE: THIS OPERATOR COMES WITH AN INTERFACE MODULE INTEGRATED INTO THE CONTROL CIRCUIT. THE PURPOSE OF THE INTERFACE MODULE IS TO ALLOW FOR FAILSAFE MONITORING OF A NICE COMPATIBLE SAFETY DEVICE AS PER UL 325 (2010) REQUIREMENTS.

Important: Follow these steps carefully and in the order shown:

1) Connect Power supply

Single Phase: Connect single phase power supply to terminals L/L1 and N/L2 on the 3-pole power terminals strip. **3-phase:** Connect 3-phase power supply to terminals L1, L2 and L3 on the 3-pole power terminal strip.

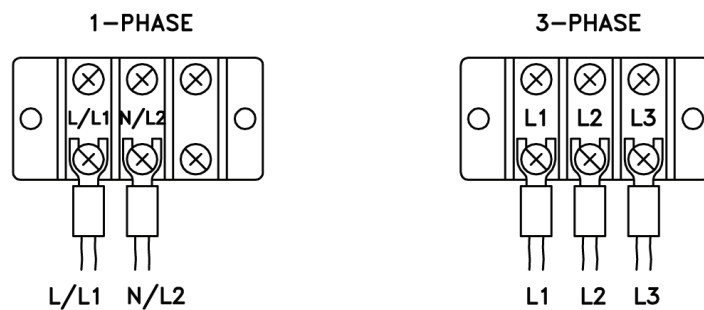

2) Connect Push-button station for installation purposes (single phase or 3-phase)

Connect open/close/stop push button station to terminals T2 (stop), T3 (common), T4 (open) and T6 (temporary CP on close).

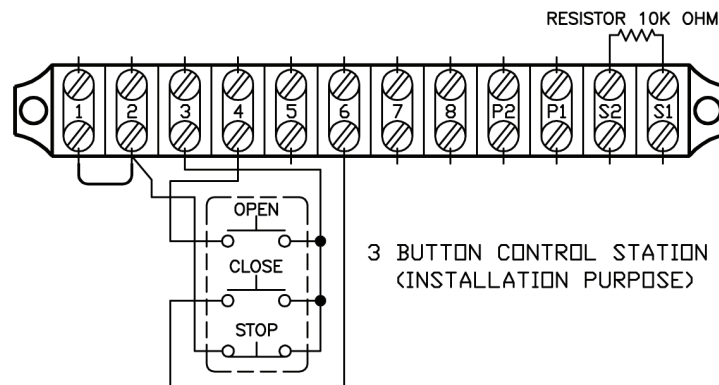

3) Verify Motor Direction

After the electrical power connections are made and push button station is connected, manually move the door to mid-position. Press Close button for several seconds and then press stop button. If door did not move in correct direction (or if limit cams not moving in correct direction towards the close limit switch) see below:

Single Phase Operators: The operators leave the factory with correct motor and limit shaft direction according to standard door installations. However, for special fire door, thru-wall mounting or other special door applications, the motor direction and limit switch direction may need to be reversed. To reverse the motor rotation, interchange black and white wires going to motor on the reversing contactor.

3-Phase Operators: If door moves in wrong direction, turn off incoming power and reverse any two of the three incoming power supply leads to correct rotation. Press the open button and then activate the open limit to ensure door stops. If door does not stop, interchange gray and red wires on open and close limits. Interchange white and gray wires on advanced open and advanced close limits. Remove blue wire from advanced open limit and place it on N.O. pin of advanced close limit.

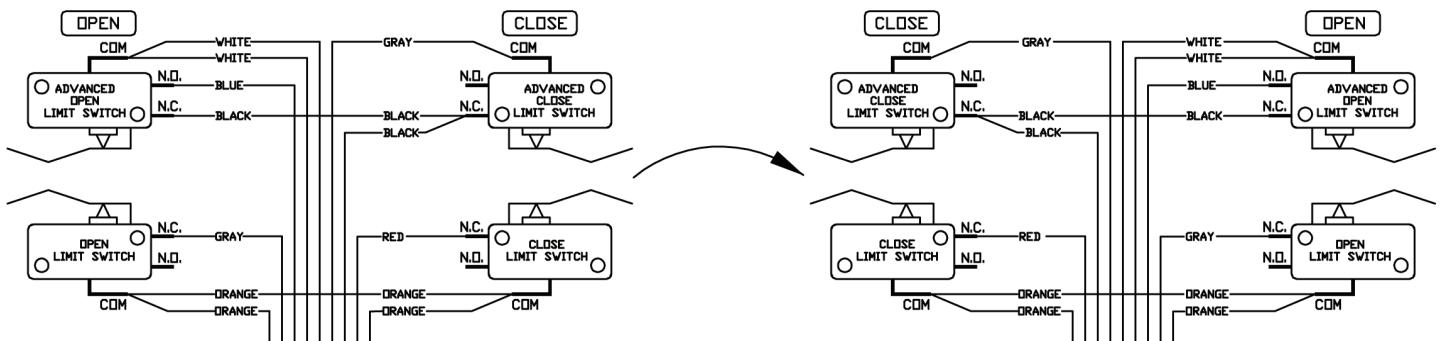

4) Adjust Limit Switch Cams

Using the open/close/stop push button station move door to fully closed and fully open positions and set limit cams to correct position. (See Limit adjustment section D further in this manual for complete detail on the end of travel limit adjustments).

5) Activate Interface Module

After adjusting the open and close limits and verifying the motor rotation, open the door to the full-open position using the open push button (Figure below on left).

At this point the close pushbutton wire must now be moved from terminal T6 to T5. Now connect the black wire (with blue label) to terminal T1 as shown in figure below on right.

NOTE: Ensure the door is in the full open position before connecting the black wire. If door is not in full open position and monitored photo-eyes or safety edge are not connected and operational then door will immediately move in the open direction.

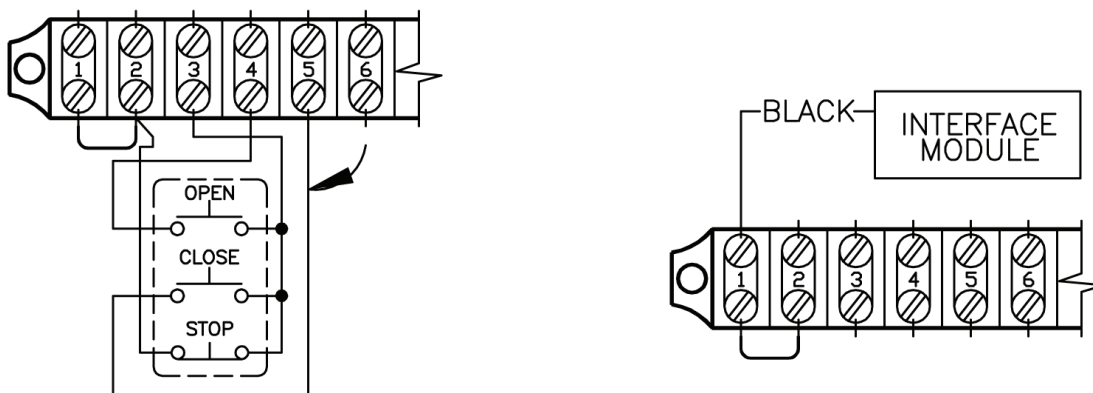

6) Connect Safety Devices

Failsafe Feature: A monitored failsafe safety feature is built into the operator. The operator has provisions to connect one primary monitored safety device as well as one or more non-monitored safety device(s).

Primary monitored safety device:

Nice monitored failsafe photo beams or Nice compatible monitored failsafe devices must be connected to terminals P1 and P2 if momentary close on pushbutton is required (B2 mode). If not connected, door can only be closed by constant pressure on close pushbutton. If constant pressure on close pushbutton is removed before door reaches full closed position, then door reverses to full open.

NOTE: Only one monitored failsafe safety device can be connected across terminals P1 and P2.

NOTE: See section E for complete installation instructions for the Nice N-1 or the Fraba photocells.

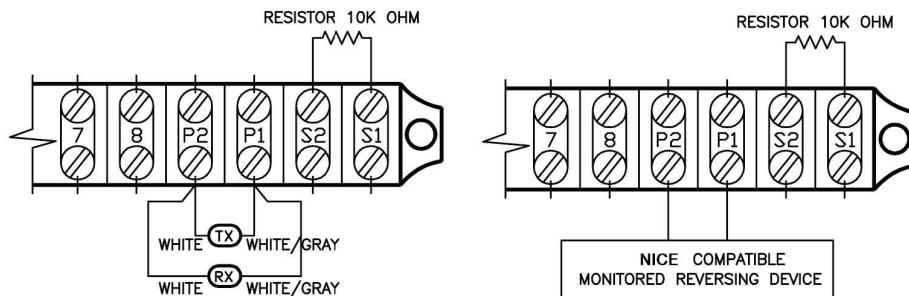

Secondary Non-Monitored Safety Device(s):

A standard 2-wire safety edge, non-monitored reflective or thru-beam photo eye or any other non-monitored reversing devices with a N.O dry contact can be connected to terminals S1 and S2.

NOTE: More than one secondary non-monitored safety device can be connected to terminals S1 and S2.

IMPORTANT: Do not remove resistor that is factory installed across terminals S1 and S2 unless installing a 4-wire electric edge.

4-Wire Electric Edge Connection

A standard 4-wire electric edge can be connected across S1 and S2 terminals as a secondary safety device. Remove the factory installed resistor across terminals S1 and S2, and install resistor across the black and white pair of wires from the electric edge and connect the remaining black and white wire to the S1 and S2 terminals.

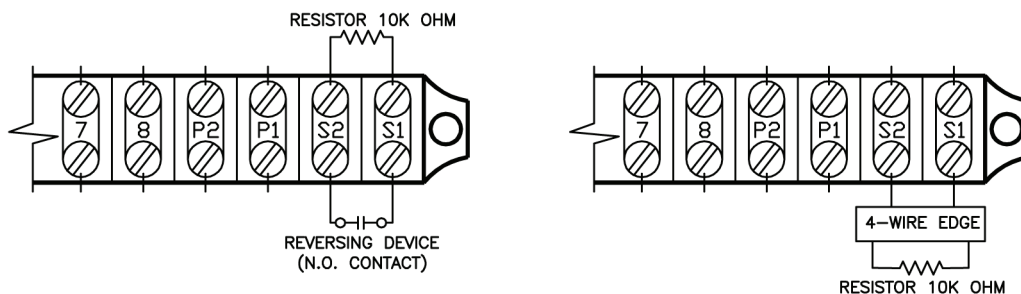

7) Select Mode of Operation

C2 mode of operation (momentary on open, constant pressure on close):

The operator is wired at the factory for momentary on open and constant pressure on close. For commercial operators, white wire is connected to terminal T6.

B2 mode of operation (momentary on open, momentary on close):

If momentary on close is required: For commercial operators, remove the white wire from terminal T6 and place it on terminal T3.

The operator functions in B2 mode only when the primary monitored safety device is connected and functioning properly. If it is not connected, operator will go into fault mode and door can only be closed by constant pressure on close and if constant pressure on close is removed before door reaches full close position, door reverses to full open.

SECTION C: PRO-GT(E): Full Feature Logic Board Smart 10.0

[UL325 (2010) Compliant]

NOTE: The operator is shipped from the factory in the D1 mode setting (constant pressure open and close). The operator should remain in this mode until all connections and limit switch adjustments are completed.

Power Wiring Instructions

Connect primary power supply directly to the separate power terminal strip supplied using any of the 1-1/8" (2.85 cm) diameter holes provided on control box. Do not connect power supply directly to the circuit board.

Single Phase: Connect single-phase power supply to terminals L/L1 and N/L2 on three-pole power terminal strip (110V or 220V 1-phase).

Three-Phase: Connect three-phase power supply to terminals L1, L2 and L3 on three-pole power terminal strip (208V, 230V, 380V, 460V or 575V).

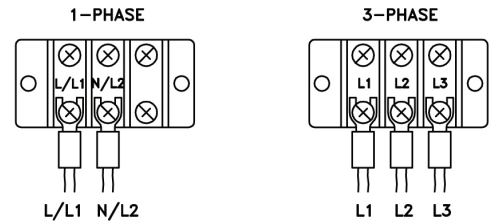

On Board O/C/S PBS Instructions

On-board Open, Close and Stop buttons are provided directly on the board for installation and troubleshooting purposes. In order to operate unit by on-board Open, Close, Stop buttons, the factory installed jumper (#1) between the COM and STOP terminals on the terminal strip must remain connected.

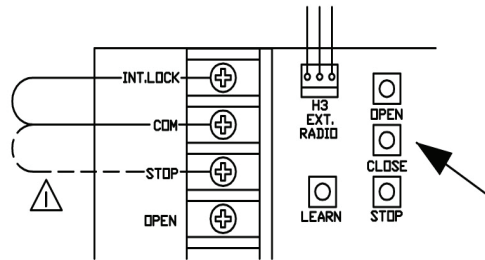

Motor Direction Verification

Make sure the mode of operation is selected to D1.

After electrical power connections are made, manually move door to mid-position. Using the on-board buttons press the "Open" button for several seconds and then press the "Stop" button. If door did not move in correct direction (or if limit cams not moving in correct direction towards the open limit switch) see below:

For Single-Phase Operators: The operators leave the factory with correct motor and limit shaft direction according to standard door installations. However, for special fire door, through wall mounting or other special door applications, the motor direction and limit switch direction may need to be reversed. A dipswitch (Dip #1) is provided to reverse direction of motor and limit switch direction. If motor direction is reversed, the open and close limit switches are automatically reversed. However, the advanced close limit switch needs to be manually changed. Disconnect the 2 wires from the advanced closed limit switch and re-connect to the auxiliary limit switch provided.

NOTE: Ensure that when the on-board open button is depressed and the door moves in the correct open direction that activation of the open limit switch illuminates the "OPEN LIMIT" LED and stops the door.

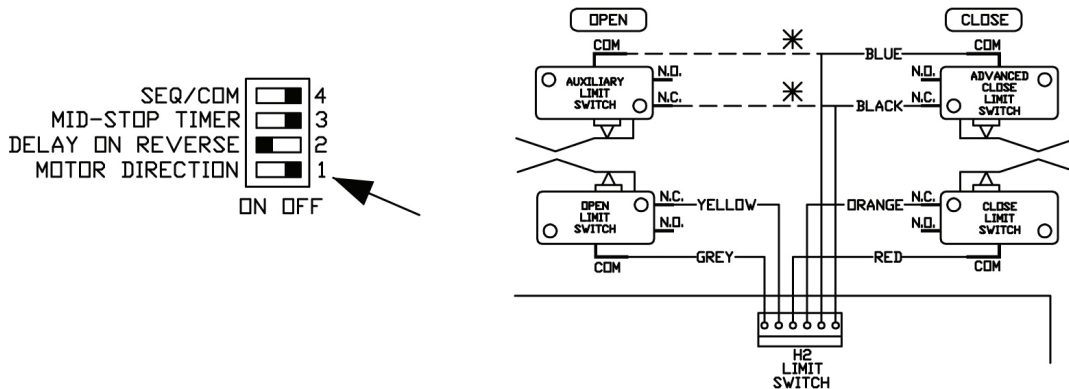

For 3-Phase Operators: If door moves in wrong direction, turn off incoming power and reverse any two of the three incoming power supply leads to correct rotation. Press the on board open button again. If door is going in the correct open direction, activate the open limit switch to ensure door stops. If door does not stop, turn off incoming power and interchange any two incoming power lines once again and slide dipswitch #1 to reverse motor direction. If motor direction is reversed, the open and close limit switches are automatically reversed. However, the advanced close limit switch needs to be manually changed. To do this, disconnect the 2 wires from the advanced limit switch and re-connect to the auxiliary limit switch provided.

NOTE: Ensure that when the on-board open button is depressed and the door moves in the correct open direction that activation of the open limit switch illuminates the "OPEN LIMIT" LED and stops the door.

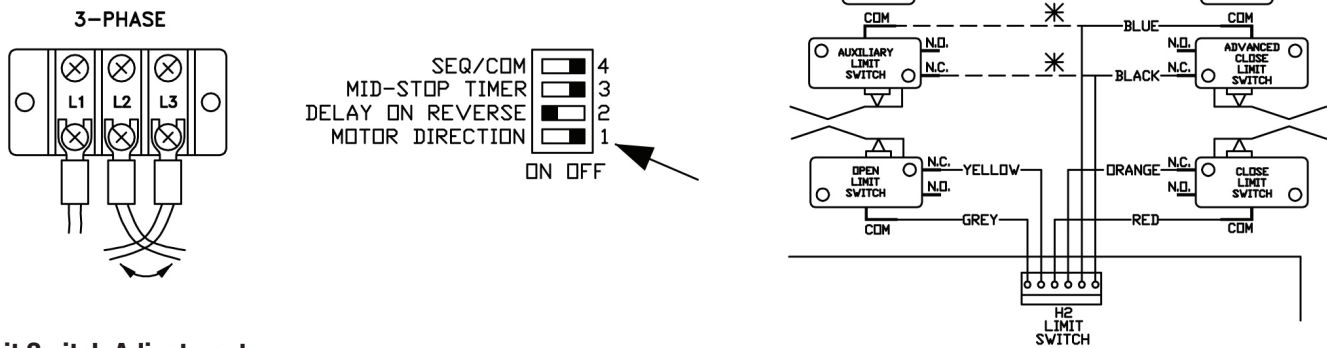

Limit Switch Adjustments

Once the motor rotation and limit cam direction have been verified, adjust the limit cam settings. Please note that when each limit switch is activated the corresponding LED will light up. Refer to operator installation manual for complete limit switch adjustment instructions.

Connection of External O/C/S PBS

Connect O/C/S PBS as shown in diagram.

NOTE: Jumper #1 must be removed after the external O/C/S PBS has been installed.

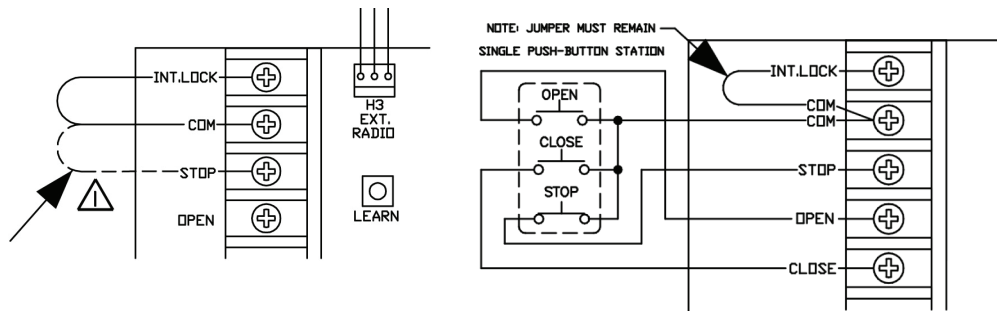

Failsafe Feature

A safety device failsafe feature is built into the logic board. The logic board has provisions to connect one primary monitored safety device as well as 1 or more secondary non-monitored safety device(s).

Primary monitored safety device

Nice monitored failsafe photo beams or Nice compatible monitored failsafe devices must be connected to terminals P1 and P2 as primary monitored safety device. Primary monitored safety device must be connected if momentary activation on close is required in B2, T and TS modes. If it is not connected in B2, T and TS modes, door can only be closed by constant pressure on close and if constant pressure is removed before door reaches full close position, door reverses to full open.

NOTE: Only one monitored failsafe device can be connected to terminals P1 and P2.

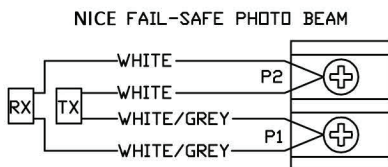

IMPORTANT!
NICE MONITORED SAFETY DEVICES MUST BE CONNECTED IF MOMENTARY ACTIVATION ON CLOSE IS REQUIRED.

Secondary Non-Monitored Safety Device(s):

A standard 2-wire safety edge, non-monitored photo beams or any other non-monitored reversing devices with a N.O contact can be connected to terminals S1 and S2 as secondary non-monitored safety device.

NOTE: More than one secondary non-monitored safety device can be connected to terminals S1 and S2.

IMPORTANT: Do not remove the resistor that is factory installed across terminals S1 and S2 unless installing a 4-wire electric edge.

4-wire electric edge:

A standard 4-wire electric edge can be connected across S1 and S2 terminals as a secondary safety device.

Remove the factory-installed resistor across terminals S1 and S2 when using a 4-wire electric edge.



Connection of External Single-Button Device

Connect an external single-button as shown in diagram. Please refer to “Modes of Operation” for the functionality of single-button.

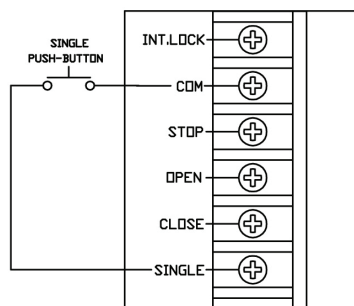

Modes of Operation

All operators leave the factory in the D1 mode setting; please read all modes of operation and determine which operational mode is desired.

B2 (Momentary on open and close):

- **Open Button:** Momentary activation opens the door. When door is closing, momentary activation reverses the door (OPEN OVERRIDE). Momentary contact from mid-stop opens the door to full open position. Constant activation when door is opening, bypass mid-stop if enabled.
- **Close Button:** Momentary on close.
- **Stop Button:** Momentary activation stops the door.
- **Single Button Device and Single Channel Transmitter, 3-Channel (1,2,3) Transmitter:**
 - » **SEQUENTIAL FUNCTION:** Open/Stop/Close/Reverse.
 - » **COMMERCIAL FUNCTION:** Open/Close/Reverse.
- **3-Button O/C/S Radio Transmitter:** Same as open, close and stop buttons.
- **Safety Devices:** When door is closing, momentary activation reverses the door.
- **Timer to Close:** N/A

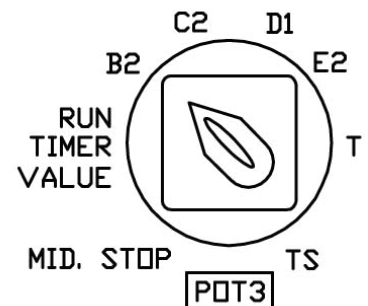

C2 (Momentary open, constant pressure close):

- **Open Button:** Momentary activation opens the door. When door is closing, momentary activation reverses the door (OPEN OVERRIDE). Momentary contact from mid-stop opens the door to full open position. Constant activation when door is opening, bypass mid-stop if enabled.
- **Close Button:** Constant pressure on close. Door will stop when button is released
- **Stop Button:** Momentary activation stops the door.
- **Single Button device:**
 - » **SEQUENTIAL FUNCTION:** Open/Stop/Constant pressure on close/stop.
 - » **COMMERCIAL FUNCTION:** Open/Constant pressure on close/stop.
- Single channel transmitter, 3-channel (1,2,3) transmitter and 3-button O/C/S radio transmitter. Momentary activation opens the door. Momentary contact of OPEN button on 3-button (O/C/S) radio transmitter from mid-stop opens the door to full open position. Cannot close the door.
- **Safety Devices:** When door is closing, momentary activation reverses the door.
- **Timer to Close:** N/A

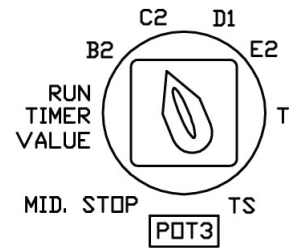

D1 (Constant pressure on open and close):

- **Open Button:** Constant pressure opens the door. Door stops when constant pressure is released. Constant pressure from mid-stop opens the door to full open position.
- **Close Button:** Constant pressure on close. Door will stop when button is released
- **Single Button device, single channel transmitter, 3-channel (1,2,3) transmitter and 3-button (O/C/S) radio transmitter:** N/A
- **Safety Devices:** When door is closing, momentary activation reverses the door.
- **Timer to Close:** N/A

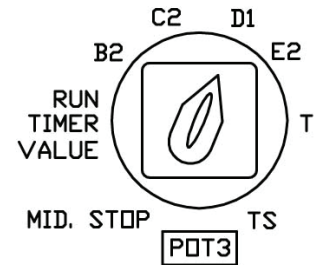

E2: (Momentary on open, constant pressure on close with roll-back feature)

- **Open Button:** Momentary activation opens the door. When door is closing, momentary activation reverses the door. Momentary contact from mid-stop opens the door to full open position. Constant activation when door is opening, bypass mid-stop if enabled.
- **Close Button:** Constant pressure on close. Door reverses to full open when button is released.
- **Single Button:**
 - » **SEQUENTIAL FUNCTION:** Open/Stop/Constant pressure on close/stop.
 - » **COMMERCIAL FUNCTION:** Open/Constant pressure on close/reverse.
- **Single channel device, 3-channel (1,2,3) transmitter and 3-button (O/C/S) radio transmitter:** Momentary activation opens the door. Momentary contact of OPEN button on 3-button (open/close/stop) radio transmitter from mid-stop opens the door to full open position. Cannot close the door.
- **Safety Devices:** When door is closing, momentary activation reverses the door.
- **Timer to Close:** N/A

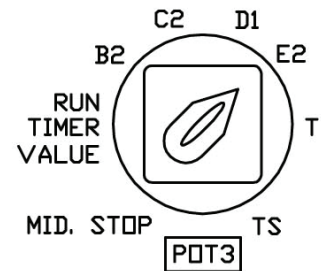

T: (Momentary on open and close, timer to close, SAFETY ACTIVATION & STOP BUTTON DISABLE TIMER)

- **Open Button:** Momentary activation opens the door. When door is closing, momentary activation reverses the door. Momentary contact from mid-stop opens the door to full open position. Momentary contact at full-open refreshes the timer if enabled at full open. Momentary contact at full open position re-activates the timer if timer is disabled previously by stop button or safety device. Constant activation when door is opening, bypass mid-stop if enabled.
- **Close Button:** Momentary on close.
- **Single Button:** If door is opening or closing, momentary activation stops the door. Momentary activation while timer is counting at mid-stop or full open deactivates the timer.
- **Single button device, single channel and 3-channel (1,2,3) radio transmitter:**
 - » **SEQUENTIAL FUNCTION:** Open/Stop/Close/Reverse.
 - » **COMMERCIAL FUNCTION:** Open/Reverse/Refresh timer.
- **3-button (O/C/S) Transmitter:** Same as open, close, stop buttons.
- **Safety Devices:** When door is closing, momentary activation reverses the door to full open AND DISABLES TIMER.

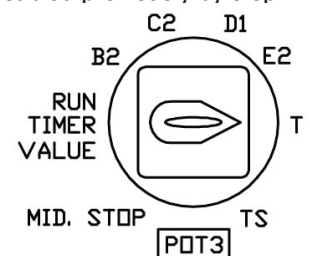

- **Timer to Close:** Closes the door from mid-stop or full open. Momentary activation of stop button will deactivate the timer. When door is closing, momentary activation of safety devices will reverse the door to mid-stop (if enabled) or full open and deactivates the timer. Timer resumes its normal operation upon momentary activation of open push button or once the close cycle is completed. If mid-stop is enabled and “Timer from mid-stop only” dip-switch is ON, timer is enabled only from mid-stop and disabled from full open. If mid-stop is enabled and “Timer from mid-stop only” dip-switch is OFF, timer is enabled from full open and mid-stop.

TS: (Momentary on open and close, timer to close secure, STOP BUTTON DISABLES TIMER)

- **Open Button:** Momentary activation opens the door. When door is closing, momentary activation reverses the door. Momentary contact from mid-stop opens the door to full open position. Momentary contact at full open refreshes the timer if enabled at full open. Momentary contact at full open position re-activates the timer if timer has been disabled previously by stop button. Constant activation when door is opening, bypass mid-stop if enabled.
- **Close Button:** Momentary on close.
- **Stop Button:** If door is opening or closing, momentary activation stops the door. Momentary activation while timer is counting at mid-stop or full open deactivates the timer.
- **Single button device, single channel transmitter and 3-channel (1,2,3) radio transmitter:**
 - » **SEQUENTIAL FUNCTION:** Open/Stop/Close/Reverse.
 - » **COMMERCIAL FUNCTION:** Open/Reverse/Refresh timer.
- **3-button O/C/S radio transmitter:** Same as open, close, stop buttons.
- **Safety Devices:** When door is closing, momentary activation reverses the door. Momentary activation refreshes the timer to close.
- **Timer to Close:** Closes the door from mid-stop or full open. Momentary activation of stop button will deactivate the timer. Timer resumes its normal operation upon momentary activation of open push button or once the close cycle is completed. If mid-stop is enabled and “Timer from mid-stop only” dip-switch is ON, timer is enabled only from mid-stop and disabled from full open. If mid-stop is enabled and “Timer from mid-stop only” dip-switch is OFF, timer is enabled from full open and mid-stop.

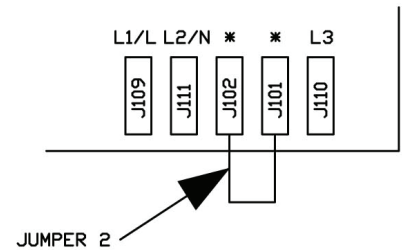
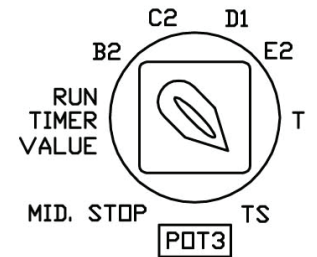

WARNING: When replacing the logic board in a single-phase operator. Make sure that Jumper 2 is installed properly before operating the door. Failure to do this will damage the logic board.

Programming Instructions

NOTE: ALL PROGRAM FUNCTIONS CAN BE INITIATED BY TURNING SELECTOR SWITCH TO THE DESIRED SETTING AT ANY POINT DURING OPERATION EXCEPT FOR THE MID STOP and RUN TIMER MODE. PROGRAMMING MUST START FROM THE FULL CLOSED POSITION.

Run-Timer Setup

Run-timer is the maximum amount of time the motor will run upon receiving an open or close command. The factory default value for run-timer is 45 seconds.

NOTE: Limits must be set prior to setting run-timer.

Modify the run-timer from factory default:

1. Close the door to full close position.
2. Set the selector dial to “Run-timer” position. The “Delay On Close Timer”. LED should blink.
3. Press open button. Wait until door reaches full open position. The run timer value is set to the time taken for the door to travel from full close position to full open position plus 5 seconds.
4. Set the selector dial to the desired mode of operation.

Modify the run-timer to factory default:

1. Close the door to full close position.
2. Set the selector dial to “Run-timer” position.
3. Press **Stop Button**. The run-timer is modified to the factory default value. Then set the selector dial to the desired mode of operation.

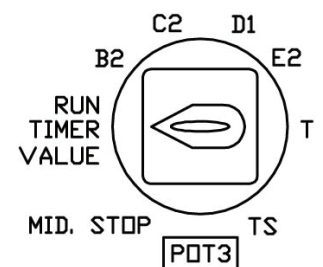

Mid-Stop Setup

Mid-Stop feature can be used to open the door to a preset point prior to full open position.

NOTE: Limits must be set prior to setting mid-stop position.

To Activate Mid-Stop:

1. Close the door to full close position.
2. Set the selector dial to “Mid-Stop” position. “Mid-Stop” LED starts blinking.
3. Press open push button. Door opens. Once the door reaches the desired mid-stop position, stop the door by activating stop push button.
4. Set the selector dial to the desired mode of operation.

NOTE: When door opens to the programmed mid-stop position, “Mid-Stop” LED will illuminate.

To De-activate the Mid-Stop position:

1. Close the door to full close position.
2. Set the selector dial to “Mid-Stop” position.
3. Press the stop button, Mid-Stop is deactivated.

Modify mid-stop position:

To modify the current mid-stop position, follow the same steps to activate mid-stop. The new mid-stop position will override the old mid-stop position.

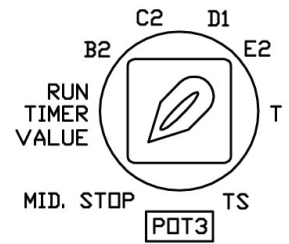

Timer to Close Setup

Timer to close is enabled only in TS and T modes of operation. To adjust the timer value turn POT1 clockwise to the desired value. The minimum value for timer to close is 3 seconds and the maximum value is 300 seconds.

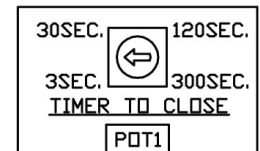

Delay on Close Setup (only for use with optional apartment board)

Delay on close timer can be used to delay the closing of the door in B2 and TS modes of operation. This timer is deactivated in C2, D1, E2 and T modes of operation. Delay on close timer is OFF when the “Delay on close” dial is set to OFF position. To adjust this timer, rotate the dial clockwise to the desired value. The minimum value for delay on close timer is 1 second and the maximum value is 60 seconds. It is recommended to use this feature in apartment applications where RED and GREEN traffic lights are used.



NOTE: In TS mode, the “Delay on close” timer starts only once the “Timer to close” has finished counting. Unless a delay on close is required this dial should be rotated to the OFF position. If left in any other position but OFF, activation of close button will delay to POT2 amount of time.

On-Board Receiver Programming

This logic board has a built-in 372 MHz radio receiver and can only be used with Nice single button, 3-button (OPEN/CLOSE/STOP) and 3-channel radio transmitters.

Installing the Antenna

Direct Connection:

Attach the antenna when supplied with the operator to the F connector on the control box. For best reception, keep antenna wire straight and away from metal objects.

Indirect connection (Mounting the antenna at a remote location):

1. Connect coax extension cable (optional) to the F connector on the control box.
2. Route cable inside metal enclosure.
3. Route and secure cable away from moving parts.
4. Mount antenna holder (not provided) outside enclosure.
5. Attach antenna to extension wire.
6. Position antenna wire straight. For best reception, keep antenna away from metal.

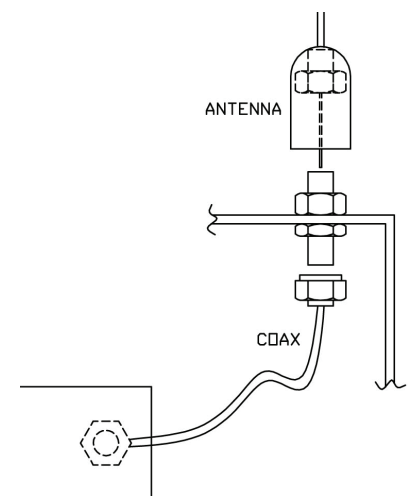

NOTE: Do not route coax cable near any moving parts of the operator. If necessary, secure coax wire away from any moving part

Programming the On-Board Radio Receiver

WARNING: During programming, door operator will activate. Keep people and objects away from door.

1. Connect power to door operator.
2. Press and release the learn button once. The receiver's LED will turn on.
3. To program a single button transmitter, press the button on the transmitter. The receiver's LED will blink twice indicating a successful programming.
4. Press the button on the transmitter once more to confirm operation of the door operator.
5. To program a 3-channel (1,2,3) transmitter, press any of the 3 buttons on the transmitter. The receiver's LED will blink twice indicating a successful programming. Press the same button on the transmitter to confirm operation of the door operator. This button is now associated with that particular receiver. You can repeat the programming process for the other two buttons to control two other receivers.
6. To program a 3-button (O/C/S) transmitter, press OPEN button on the transmitter. The receiver's LED will blink twice indicating a successful programming. Press the OPEN button on the transmitter to confirm operation of the door operator. The OPEN, CLOSE and STOP buttons on the transmitter can be used to open, close or stop the operator respectively.
7. Test range of transmitter. Repositioning antenna may provide greater range.
8. Repeat transmitter-programming steps for additional transmitters.

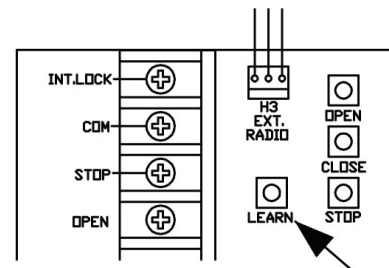

Operation

1. Press and release the button on Nice transmitter.
2. Receiver LED will light momentarily and door will cycle.

To Erase all Learned Transmitters

1. Press and hold down the LEARN button.
2. After 5 seconds, the LED will blink for 5 seconds.
3. Release the LEARN button during the time LED is blinking.
4. After you released the button, the LED will blink 5 times indicating all transmitters are erased from the receiver's memory.

NOTE: A maximum of 20 transmitters can be programmed for the same receiver. If more than 20 are required, consult factor.

Replacing Remote Control Batteries

The batteries (lithium, 3V) should produce power for up to 5 years. To replace the battery, open the transmitter by removing the screws on the back of the transmitter. Match the positive and negative terminals of the battery to the positive and negative terminals of the transmitter.

NOTE: The receiver and transmitter comply with part 15 of the FCC rules with RSS-210 of industry Canada. Operation is subject to the following two conditions: (1) this device may not cause harmful interference, and (2) this device must accept any interference received, including interference that may cause undesired operation.

NOTE: If an external radio-receiver (Nice or other) is used instead of the built-in radio receiver, it is highly recommended to disconnect the co-axial cable from the logic board.

NOTE: When using any external receiver, the Nice on-board receiver should not be used.

Dip-Switch Setup

DIP-SWITCH	ON	OFF	NOTE
SEQ/COM	Single button and radio in SEQ mode	Single button and radio in COM mode	
Mid-stop Timer	Timer is enabled from mid-stop only	Timer is enabled from both mid-stop and full open	T or TS mode can be selected to enable a timer for mid-stop
Delay on reverse	Delay on reverse is 1.5 seconds	Delay on reverse is 0.5 seconds	Nice recommends 1.5 second delay on reverse for all applications
Motor direction	Reverse motor direction	Standard motor direction	See NOTE ** below

NOTE: If motor direction is reversed, the open and close limit switches are automatically reversed. However, the advanced close limit switch needs to be manually changed. To do this, disconnect the 2 wires from the advanced closed limit switch and re-connect to the auxiliary limit switch provided.

Status LED

LED	Status	Cause
Fault	ON	<ul style="list-style-type: none"> » Primary safety devices not connected to P1 & P2 or not functioning properly » Safety devices are activated » 10k Ohm resistor (between S1 & S2) removed or faulty
Fault	Blinking	<ul style="list-style-type: none"> » Interlock is activated. » Interlock jumper is not connected
Run-out-timer	ON	Run-out timer has elapsed
Delay on close timer	Blinking	<ul style="list-style-type: none"> » Delay on close timer is counting » Selector dial is set to Run-timer
Timer to close	Blinking	Timer to close is counting.
Safety/Photo	ON	<ul style="list-style-type: none"> » Primary safety devices not connected to P1 & P2 or not functioning properly » Safety devices are activated » 10k Ohm resistor (between S1 & S2) removed or faulty
Mid. Stop	ON	Door is at Mid-stop position.
Close Limit	ON	Close limit switch is activated.
Open Limit	ON	Open limit switch is switched
Stop PB	ON OFF	<ul style="list-style-type: none"> » Stop button connected and functioning » Stop push button is activated (or the stop circuit is open).
Close Relay	Blinking	<ul style="list-style-type: none"> » Door is closing » Close relay is activated
Open Relay	Blinking	<ul style="list-style-type: none"> » Door is opening. » Open relay is activated.
Power	ON	24 VAC power to logic board is ON.

FAULT	<input type="checkbox"/>
RUN-OUT TIMER	<input type="checkbox"/>
DELAY ON CLOSE TIMER	<input type="checkbox"/>
TIMER TO CLOSE	<input type="checkbox"/>
SAFETY/PHOTO	<input type="checkbox"/>
MID. STOP	<input type="checkbox"/>
CLOSE LIMIT	<input type="checkbox"/>
OPEN LIMIT	<input type="checkbox"/>
STOP P.B.	<input type="checkbox"/>
CLOSE RELAY	<input type="checkbox"/>
OPEN RELAY	<input type="checkbox"/>
POWER	<input type="checkbox"/>

SECTION D: For all Operator Control Types

Limit Switch Adjustment

Adjustment of door travel is done by moving the limit cams on the threaded shaft. The position of the 4 limit switches are factory adjusted and should not be altered. The limit switches are:

- **“Open” limit switch:** End of door travel in the fully open position
- **“Closed” limit switch:** End of door travel in the fully closed position
- **“Advanced Open” or “Auxiliary advanced closed” limit switch:**
 - A) For relay logic operators this advanced open limit switch is used for open/close devices or timer to close features.
 - B) For logic board this auxiliary closed limit switch is used for open/close devices used when motor direction is reverse of standard.
- **“Advanced Closed” Limit switch:** Used to prevent reversing device from reversing door when door is almost fully closed.

⚠ WARNING ⚠

TO REDUCE THE RISK OF INJURY OR DEATH: DO NOT ATTEMPT TO MAKE LIMIT SWITCH ADJUSTMENTS UNLESS POWER HAS BEEN ELECTRICALLY DISCONNECTED.

To adjust door travel:

1. **Open cycle:** Depress cam plate and spin “Open” limit cam away from “Open” limit switch to increase door travel or spin “Open” limit cam towards the “Open” limit switch to decrease door travel. After each adjustment ensure that cam plate fully engages in slots of both limit nuts.
2. Adjust “Open” limit cam so that door stops at the desired fully open position.
3. **Close cycle:** Depress cam plate and spin “Close” limit cam away from “Close” limit switch to increase door travel or spin “Close” limit cam towards the “Close” limit switch to decrease door travel. After each adjustment ensure that cam plate fully engages in slots of both limit nuts.
4. Adjust “Close” limit cam so that door stops at the desired fully closed position.

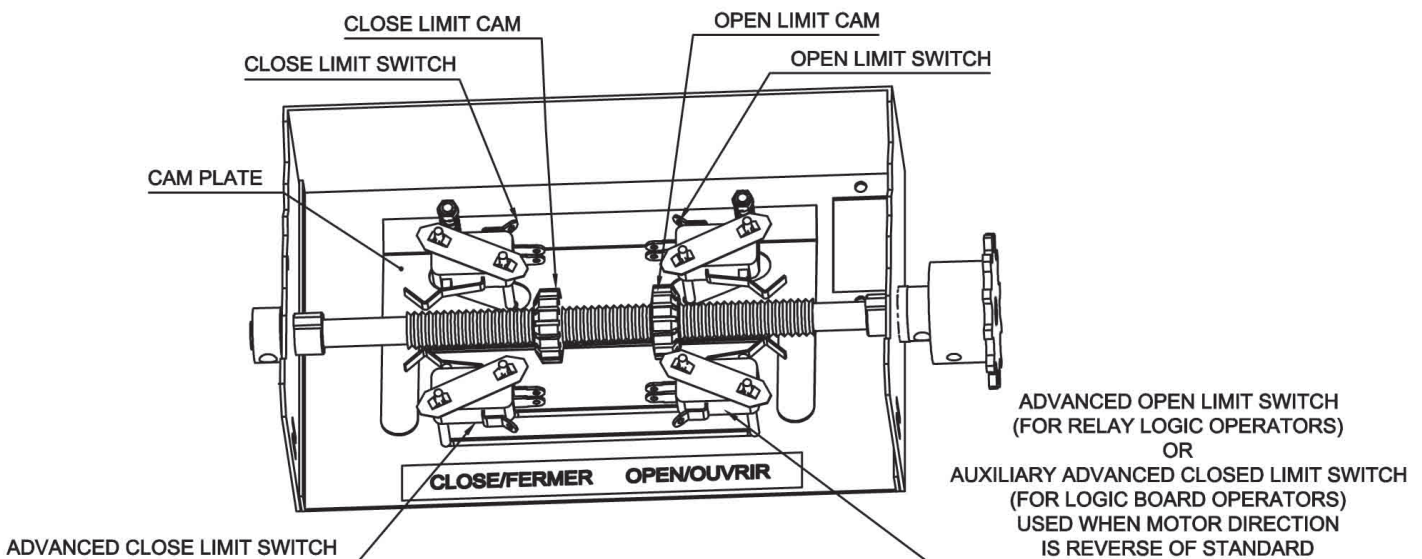

SECTION E: For Operators with Interface Modules or Logic boards

Installation of Nice N-1 or N-4 Photocells

Installation Safety Precautions

⚠ WARNING ⚠

Nice MK00649 NEMA-1 and FRABA MK00697 NEMA 4/4X infrared photo systems are for use only with Nice logic board operators or relay logic operators equipped with the Nice failsafe interface module. Use of this device on other than recommended operators can lead to severe or fatal injury. Follow these instructions carefully.

IMPORTANT

For momentary activation on close, the Nice photobeams (or a Nice 2-wire monitored edge), must be installed as part of the operator system. If a Nice 2-wire monitored edge or the Nice infrared photobeam system is not installed (or not operating correctly), the operator will only operate in fault mode "constant pressure to close".

READ and FOLLOW all installation instructions.

1. Before installing the photo beam, read the door or gate operator's instruction manual fully, so you are aware of all of the unit's functions and features.
2. Wear protective gloves and eye protection when using tools.
3. Before installing photo beam, disconnect all power to door operator to prevent unintended operation and have the door full open or close.
4. Do not reconnect power to the door or gate operator until instructed to do so.
5. Only install photobeams on a properly functioning door or gate operator.
6. Installation and wiring must comply with local building and electrical codes. This device is not intended and must not be installed in an explosive environment.

⚠ WARNING ⚠

Keep fingers and other body parts away from all moving parts of the door and gate operator system while the system is being operated.

⚠ WARNING ⚠

To prevent unintended operation, disconnect power to the door or gate operator prior to installing the photobeam system.

NICE N-1 Photocell (MK00649)

NOTE: The MK00649 photocell system has a maximum range of 24 ft. Sun visor protector optional.

Installation

NOTE: Photo beams should be mounted as close to the door track inside the door to offer maximum entrapment protection.

Wall installations

1. Select a location on the wall no more than 6 inches from the floor to install wall mounting brackets on the left and right side of the door. Both brackets must be mounted at the same height for proper alignment.
2. Drill holes in the wall and attach brackets to the wall using screws and nails provided as shown in Fig. 1.

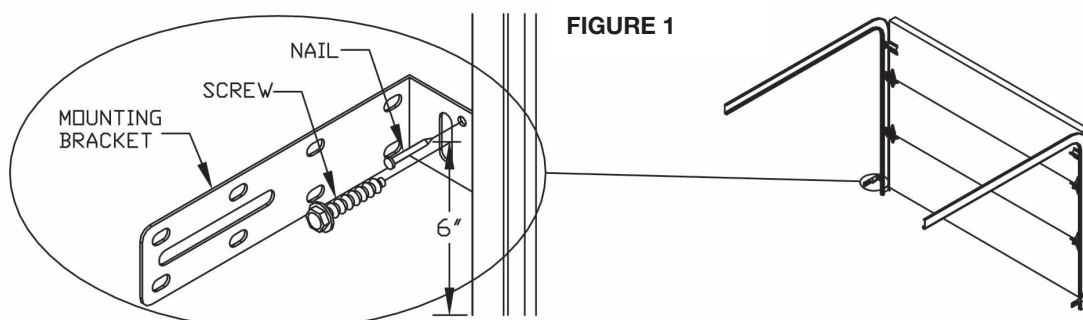

- Using the wing nuts, attach the receiver and transmitter of the photo system to the mounting brackets (with arrow pointing up). Note that the receiver and transmitter can be installed on the left side or right side of the door.
- Adjust the position of the transmitter and receiver on the slot of the brackets. Secure the receiver and transmitter to the mounting brackets as shown in figure 2.

FIGURE 2

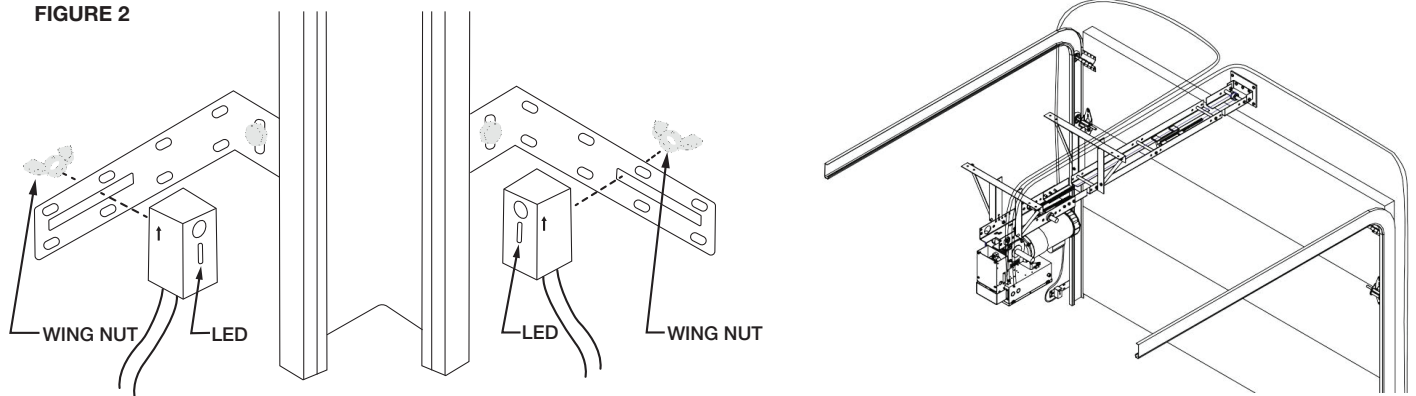

- Pair the two white wires and the two white/grey wires together from transmitter and receiver.
- Connect these paired wires to the P1 and P2 terminals on the logic board (or interface module if applicable) as shown in Figure 3.

OPERATOR LOGIC BOARD

FIGURE 3

OPERATOR RELAY LOGIC CONTROLS WITH INTERFACE MODULE

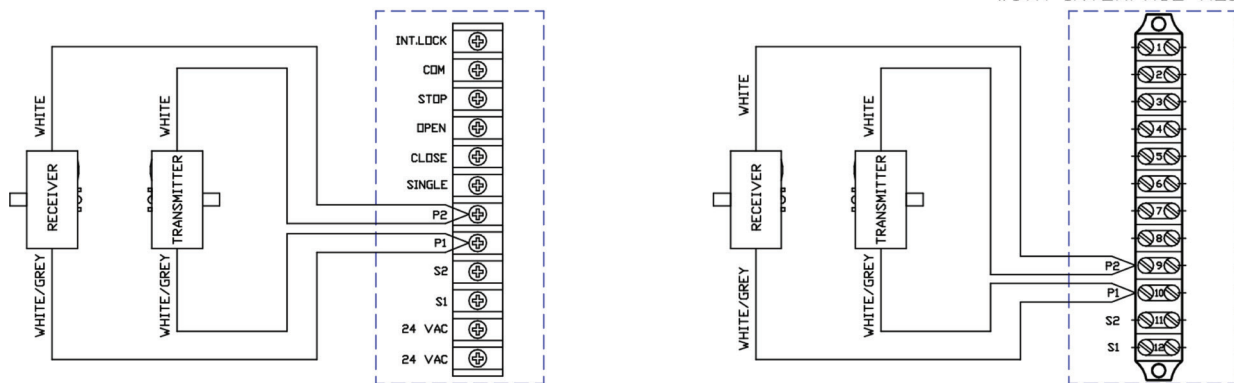

NICE N-4 Photocell (MK00650)

NOTE: The MK00650 photocell system has a maximum range of 24 ft. Sun Visor protector optional.

Installation

NOTE: Photo beams should be mounted as close to the door track inside the door to offer maximum entrapment protection.

Wall installation

- Select a location on the wall no more than 6 inches from the floor to install wall mounting brackets on the left and right side of the door. Both brackets must be mounted at the same height for proper alignment.
- Drill holes in the wall and attach brackets to the wall using screws and nails provided as shown in Fig. 1, page 24.

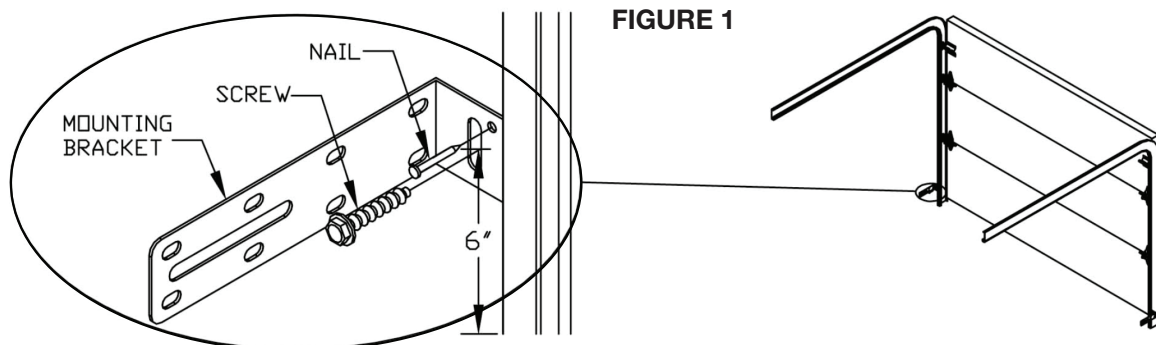

- Using the 8 Phillips head screws, attach the receiver and the transmitter to the two mounting plates (Fig. 2A).
- Using the wing nuts, attach the receiver and the transmitter of the photo system to the mounting L-brackets (with arrow pointing up) as shown in Fig. 2B. Note that the receiver and transmitter can be installed on the left or right side of the door. For applications requiring the photobeams to be further away from the wall, use the extension brackets provided as shown in Fig. 2C.

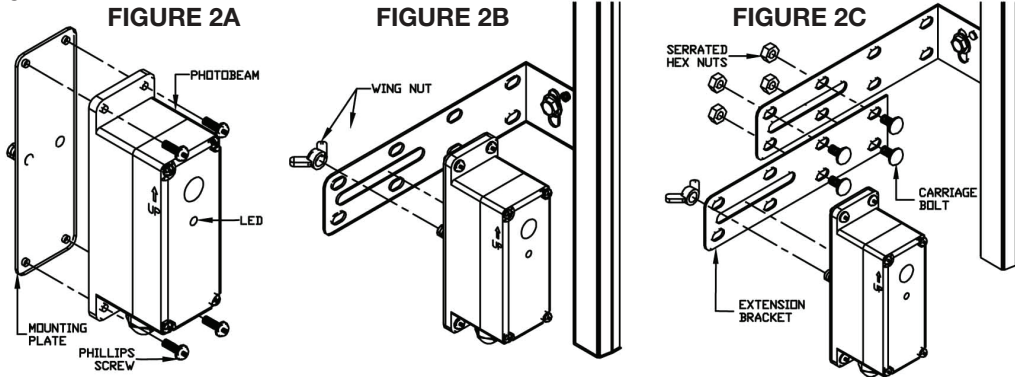

- Adjust the position of the transmitter and receiver on the slot of the brackets and tightly secure the wing nuts
- Loosen the 4 fastening screws and remove the cover from the photobeam transmitter and receiver housings and insert electrical wire through the strain relief (Fig. 3A). Pair the two white/gray wires together from transmitter and receiver.
- Connect these paired wires to the P1 and P2 terminals on the logic board (or interface module if applicable) as shown in Fig. 3B. Use minimum 18 gauge wires and secure the wires to wall or ceiling.

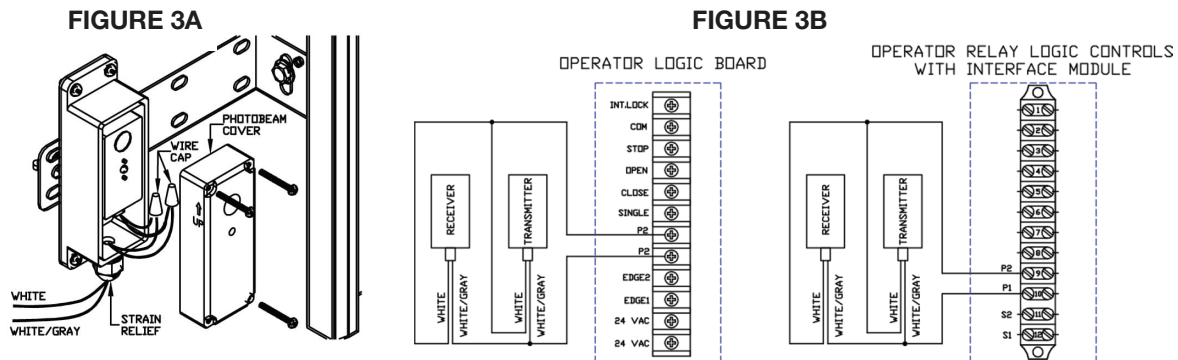

For Nice Nema-1 photobeams:

Aligning the photo beams:

- Turn the power on to the operator. If the transmitter and receiver are installed properly, the lights on both the transmitter (red LED) and receiver (green LED) will be ON.
- If the photo beams are not aligned properly, the receiver light (green) is OFF. Adjust the position of the transmitter and/or the receiver on the slot of the mounting bracket until the light on the receiver is ON and then secure to the bracket.

Photo system operation:

Nice photo beams must be connected for the door to close in momentary mode (unless a Nice monitored 2-wire edge is connected). When the photo system is properly installed and aligned, the infrared beam will detect any obstruction in the path of the beam. Upon detecting an obstruction, closing door will stop and reverse to full open.

The Nice operator control circuit continuously monitors the correct operation of the photo system. If the photo beams are not connected or not functioning properly, the operator will go into fail-safe mode and closing door will reverse to full open. In fail-safe mode door can only be closed by constant pressure on close.

To test the photo system:

- Open the door to full open position.
- Close the door.
- When door is closing, obstruct the beam. The door should stop and reverse.

FRABA N-4/4 Thru-Beam Photocell (MK00697)

NOTE: The MK00687 photocell system has a maximum range of 45 ft. Sun Visor protector optional.

1. Select a location on the wall no more than 6 inches from the floor to install wall mounting brackets on the left and right side of the door. Both brackets must be mounted at the same height for proper alignment.
2. Drill holes in the wall and attach brackets to the wall using screws provided as shown in Fig. 1.

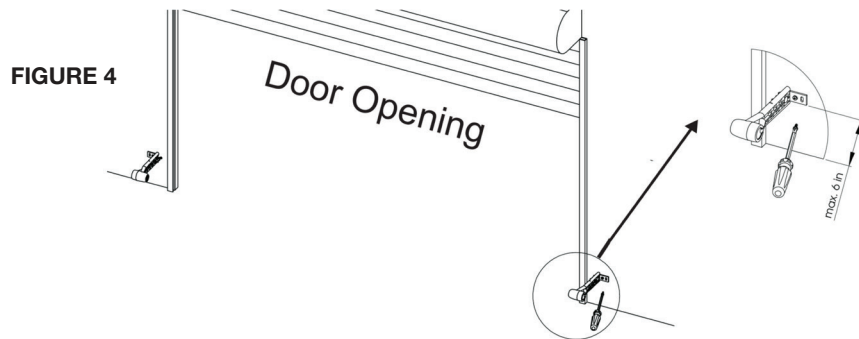

3. Plug sensors into flexible adapters as shown in Fig. 4. Please note that the 2 brackets are not identical. The receiver (Rx) must be installed into the receiver adapter and the transmitter (Tx) must be installed into the transmitter adapter (Fig. 5).

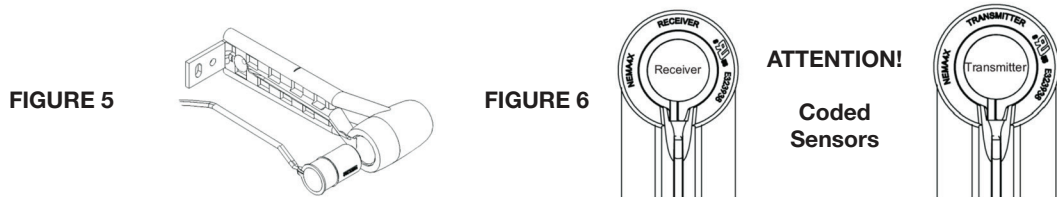

4. Pair the two black and the two black with white tracer wires together from transmitter and receiver. Connect these paired wires to the P1 and P2 terminals on the logic board (or interface module if applicable) as shown in Fig. 7. Use minimum 18 gauge wires and secure the wires to wall or ceiling.

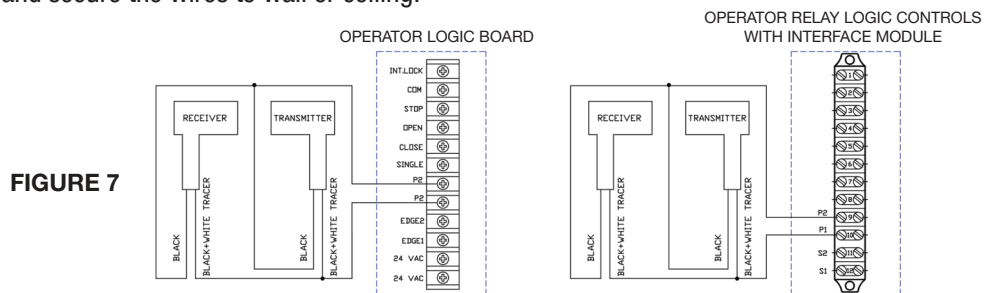

5. Turn the power on to the operator. Align transmitter and receiver by adjusting angle and height of the fixture (Fig. 8A and 8B).

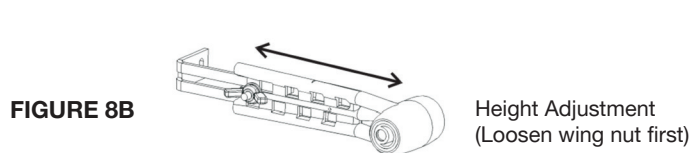
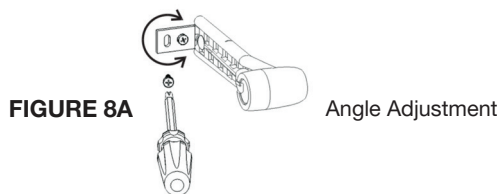

6. Utilize LEDs on photocells for alignment and trouble shooting. Make sure to tighten screws and wing nuts after photocells are aligned.
 - **Red LED (ON), Green LED (ON):** Normal operation
 - **Red LED (ON), Green LED (OFF):** No power. Verify wiring
 - **Red LED (Blinking twice), Green LED (ON):** Bad Alignment, or Obstructed Beam, or Rx defective
 - **Red LED (Blinking twice), Green LED (OFF):** Check power and wiring to Rx, or Rx defective
 - **Red LED (Blinking three times), Green LED (ON):** Rx receiving sunlight (or interference). Install visor or interchange position of transmitter and receiver to reduce sunlight affecting receiver.

To test the photo system: Open the door to full open position. Close the door. When door is closing, obstruct the beam. The door should stop and reverse.

Clutch Adjustment

1. Loosen bolts on clutch cover and slide cover towards motor to access clutch.
2. Loosen the two set screws on clutch adjustment nut.
3. Rotate clutch nut counterclockwise (loosen) until there is insufficient tension to permit clutch to drive door.

NOTE: When adjusting nut, make sure to secure input shaft to not allow shaft to rotate when tightening or loosening nut.

4. Gradually tighten clutch nut (adjust ¼ turn at a time) until the tension is sufficient to permit clutch to drive door smoothly but will allow clutch to slip if door is obstructed. It should be possible to stop moving door by hand if clutch is properly adjusted.
5. Tighten the 2 set screws after each time the unit is tested for clutch adjustment. After adjustment is completed make sure set screws are locked in place. Re-install clutch cover.

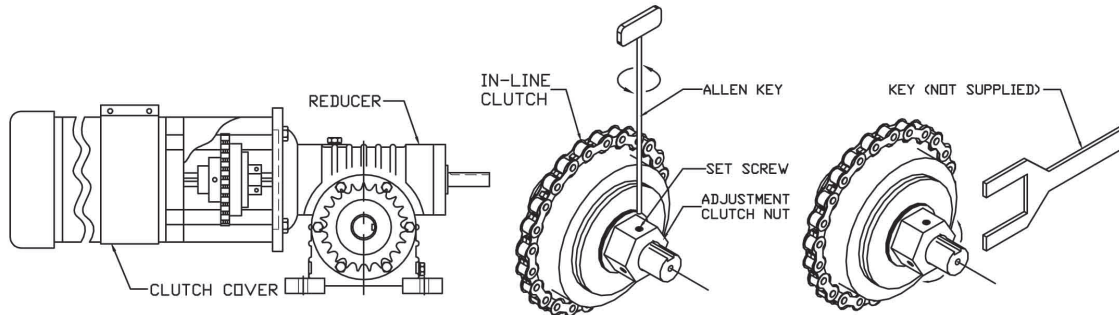

Brake Adjustment

- The brake adjustment is factory set and should only require minor adjustment after extensive use.
- Verify brake adjustment by manually holding in solenoid plunger. When brake is properly adjusted, the brake shoe pads should make complete contact with brake drum with sufficient brake spring tension to stop and maintain door when solenoid is de-energized. When solenoid is energized, brake shoes should release from drum with sufficient clearance to avoid contact between shoes and drum.
- To adjust brake tension, tighten (to increase) or loosen (to decrease) nylon lock nut on brake spring bolt. Observe solenoid during electrical testing of brake. Brake spring tension must be adjusted so that solenoid should pull and release smoothly and quietly. Too much or too little tension on brake spring may cause solenoid to burn out.
- To adjust individual brake shoes, loosen nut on brake shoe adjustment bolt and adjust bolt. When properly adjusted, there should be a small clearance between adjustment bolt and solenoid bracket when solenoid is de-energized. When solenoid is energized, brake shoes should move away from drum with sufficient clearance to avoid friction between brake shoe pad and drum. After adjustments are made be sure to tighten nuts on brake shoe adjustment bolts.

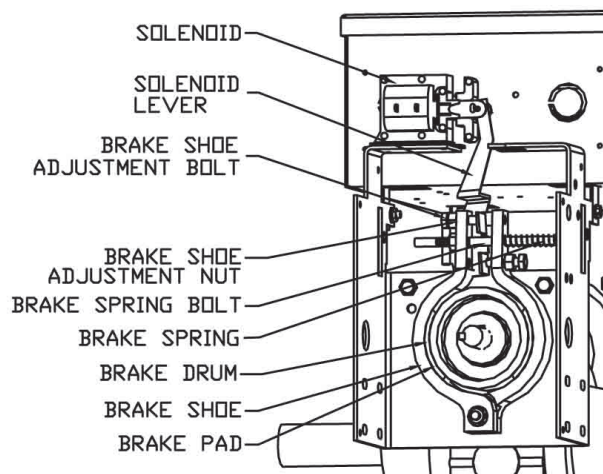

Emergency Manual Operation

The operator is equipped with a quick release disconnect system to manually operate door in case of emergency. This feature should not be used to manually operate a malfunctioning door.

⚠ WARNING ⚠

TO REDUCE THE RISK OF INJURY OR DEATH:

DO NOT ATTEMPT TO USE EMERGENCY DISCONNECT SYSTEM WHILE OPERATOR IS RUNNING.

POWER TO THE OPERATOR SHOULD BE TURNED OFF PRIOR TO OPERATING DOOR MANUALLY.

TO AVOID BEING STRUCK BY DOOR ARM, DO NOT STAND DIRECTLY UNDER THE RELEASE ARM WHEN PULLING THE RELEASE CORD.

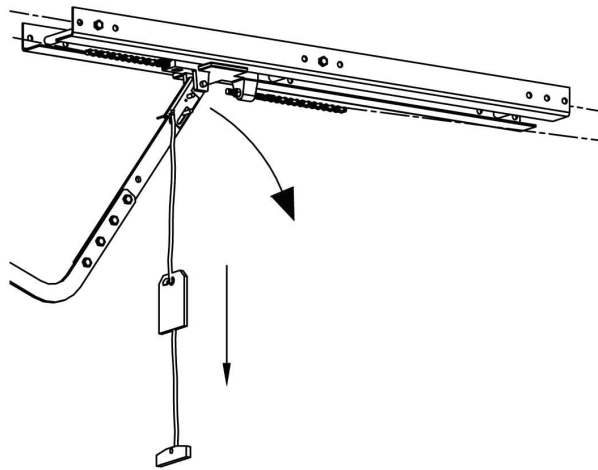

1. Pull the release cord downwards to disconnect trolley arm from carriage and manually operate door.
2. To reconnect door arm to carriage, pull emergency release cord and re-insert trolley arm to trolley carriage spring pin.

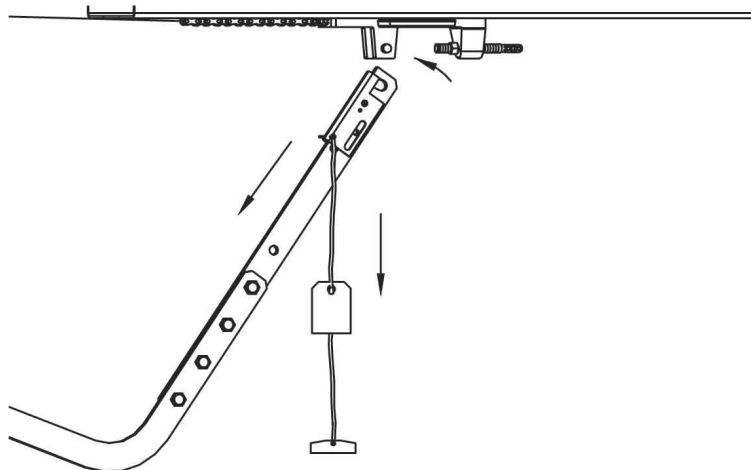

Operator Maintenance

WARNING

TO REDUCE THE RISK OF INJURY OR DEATH:

DO NOT ATTEMPT TO SERVICE THE OPERATOR UNLESS
POWER SUPPLY HAS BEEN DISCONNECTED.

- Inspect manual function of the door every 3-months. Make sure that door runs smoothly. If door does not manually open or close freely, have a qualified service person make repairs. Do not attempt to electrically operate a malfunctioning door.
- Every 3 months:
 1. Verify that door area is kept clean. Remove any obstructions that would prevent proper door operation.
 2. Check for any excessive slack in chains. If chain adjustment is required verify and adjust limit switches, if necessary.
 3. Verify and adjust clutch and brake (Do not lubricate).
 4. Lubricate chains, bearings and limit shaft.
 5. Verify that motor, solenoid and operator runs smoothly and quietly.
- Every 6 months:
 1. Verify tightness of all fasteners and set screws.
 2. Verify that operator is properly secured.
 3. Inspect manual disconnect.
 4. Verify tension and condition of V-belt.
- Every 12 months:
 1. Perform a complete service check.
 2. Verify that inside of control box is clean and that grounding wires, terminations and power terminations do not show signs of corrosion.
 3. Verify tightness of all terminal strip screws and electrical connections.
 4. Verify power supply, voltage of input terminals during operation.
 5. Verify that current consumption of operator corresponds to nameplate information.

Trolley Operator Pro-GT Diagram

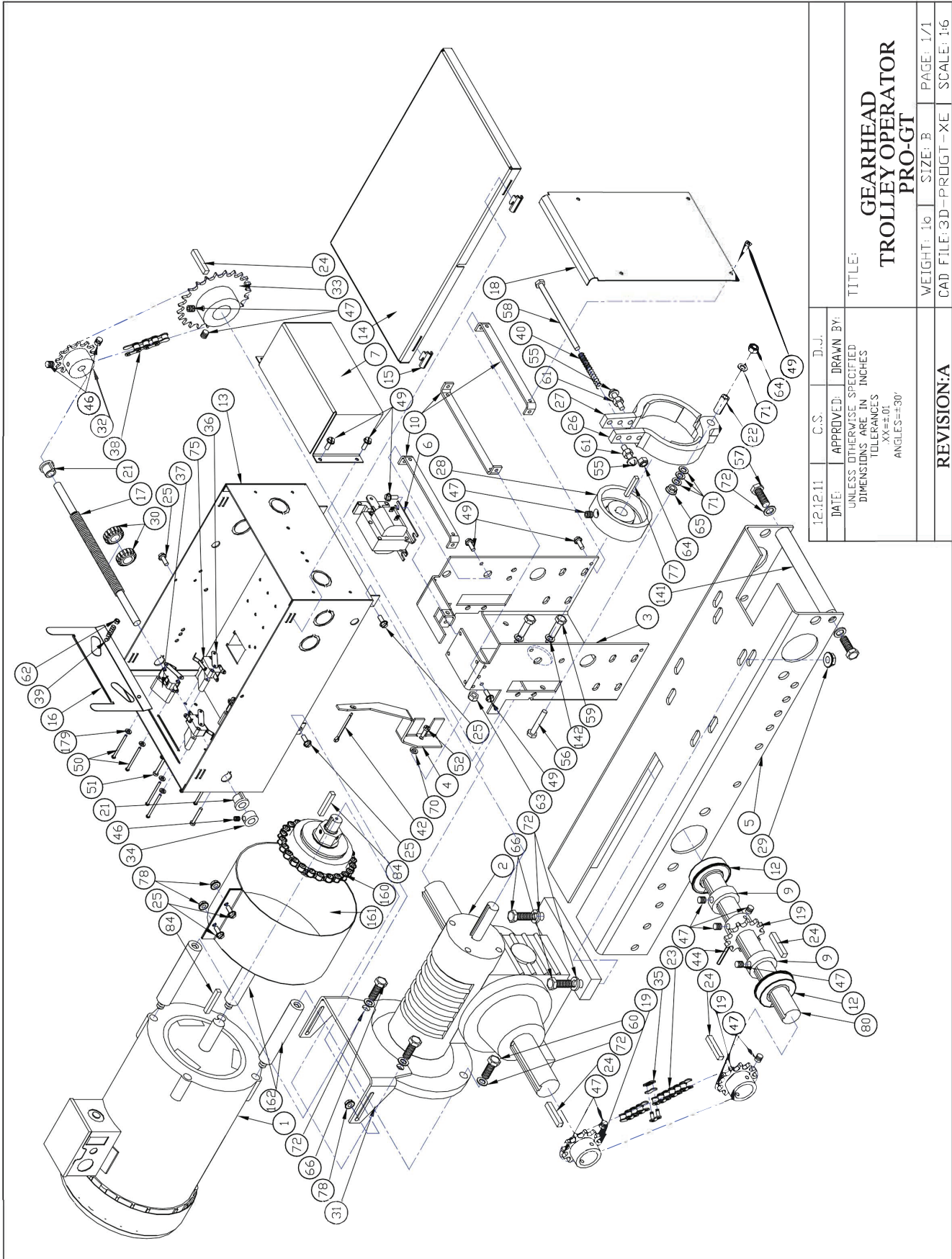

12.12.11	C.S.	D.J.
DATE:	APPROVED:	DRAWN BY:
UNLESS OTHERWISE SPECIFIED DIMENSIONS ARE IN INCHES TOLERANCES .XX=±.01 ANGLES=±30°		
REVISION:A		
TITLE: GEARHEAD TROLLEY OPERATOR PRO-GT		PAGE: 1/1
WEIGHT: 16		SCALE: 1:6
CAD FILE: 3D-PROGT-XE		SIZE: B

Trolley Operator Pro-GT Parts List

CODE	ARTICLE#	DESCRIPTION	QUANTITY
*	1	Motor	1
MC00044	2A	GEAR REDUCER CH 55 20:1 (1/2, 3/4, 1HP)	1*
MC00045	2B	GEAR REDUCER CH 70 20:1 (1.5, 2HP)	1*
MM00004	3	FRAME GEARHEAD MSI0030	1
MM00015	4	SOLENOID LEVER GEARHEAD MSI0031	1
MM00009	5	GT TUNNEL FRAME MSI0047	1
MK00026	6A	SOLENOID 120V	1*
MK00027	6B	SOLENOID 220V	1*
MK00028	6C	SOLENOID 460V	1*
MK00029	6D	SOLENOID 575V	1*
MM00012	7	SOL-COVER GEARHEAD MSI0032	1
MH00007	9	COLLAR 1" ID	2
MM00007	10	GEARHEAD FRAME SUPPORT C-BRACKETS MSI0036	3
MH00009	12	FLANGE BEARING 1" ID x 2" OD	2
MM00002	13	CONTROL BOX MSI0001	1
MM00001	14	CONTROL BOX COVER MSI0005	1
MM00046	15	CONTROL BOX HINGE	2
MM00024	16	CAM PLATE MSI0013	1
ME00001	17	LIMIT SHAFT 3/8-1/2 x 9.75"	1
MM00005	18	BACK COVER (FRAME PRO-G) MSI0037	1
MD00300	19	SPROCKET 41B14 x 1"	3
MH00001	21	BRONZE T-BUSHING 3/8" ID	2
MH00002	22	MILD STEEL BUSHING 9/32ID x 13/32OD x1-1/16	1
MD00029	23	#41 DRIVE CHAIN (63 LINKS (#55 RED), 65 LINKS (#70 RED)	1
ME00017	24	KEYWAY 1/4" SQ. x 1-1/4" LG	4
MF00046	25	H.H. SLOTTED SELF ROUNDING WASHER HEAD SCREW 10-32 UNF x 1/2"	7
MJ00001	26	BRAKE SHOE LEFT	1
MJ00002	27	BRAKE SHOE RIGHT	1
MJ00003	28	BRAKE DRUM	1
MG00013	29	RIBBED HEX NUT 3/8" - 16UNC	4
MG00030	30	LIMIT CAM 1/2-20 UNF	2
MM00027	31	REAR BRACKET GH (RED 55, 63, 70, 80) (MSI0038)	1
MD00005	32	SPROCKET 410B12 x 3/8"	1
MD00025	33	SPROCKET 410B23 x 1" bore	1
MH00006	34	COLLAR 3/8 ID	1
MD00036	35	CONNECTING LINK #41	1
MG00003	36	DOUBLE NUT FOR LIM-SW	4
MJ00006	37	LIMIT SWITCH DOUBLE SPACER 3/4" LONG	4
MD00225	38A	#410 ROLLER CHAIN 67 LINKS C/W CON. LINK (FOR REDUCER #55)	1*
MD00226	38B	#410 ROLLER CHAIN 69 LINKS C/W CON. LINK (FOR REDUCER #70)	1*
MO00001	39	CAM PLATE COMPRESSION SPRING (.178IDx.032GX.55L)	2
MO00002	40	BRAKE COMPRESSION SPRING (5/16"ID-.05G-2.50L)	1
MQ00001	42	COTTER PIN 1/8 x 1.5	1
MQ00005	44	SPRING PIN 3/16" x 1-1/2" Long	1
MQ00009	46	SET SCREW 1/4" - 20	3
MQ00008	47	SET SCREW 5/16" -18	12
MF00045	49	H.H. SLOTTED SELF ROUNDING WASHER HEAD SCREW 8-32 UNF x 3/8"	18
MF00003	50	R.H PHILLIPS MACHINE SCREW 4-40 UNC x 1-1/2	8
MF00004	51	R.H PHILLIPS MACHINE SCREW 6-32 UNC x 1	2
MF00005	52	R.H. PHILLIPS MACHINE SCREW 10-32 UNF x 5/8"	1

Trolley Operator Pro-GT Parts List

CODE	ARTICLE#	DESCRIPTION	QUANTITY
MF00048	55	ROUND HEAD SLOTTED BOLT 1/4-20UNCx1-1/4" (Full thread)	2
MF00076	56	HEX HEAD BOLT 1/4-20UNC x 2" (full thread)	1
MF00011	57	HEX HEAD BOLT 3/8" - 16UNC x 3/4"	2
MF00044	58	HEX HEAD BOLT 1/4-20UNC x 4" (Not full thread)	1
MF00032	59	H.H. BOLT 5/16"-18UNC x 3/4" LONG	4
MF00019	60	HEX HEAD BOLT 3/8-16UNC x 1 (Full thread)	2
MG00006	61	HEX NUT 1/4-20UNC	2
MG00007	62	HEX NYLON LOCK NUT 6-32UNC	2
MG00008	63	HEX NYLON LOCK NUT 10-32 UNF	1
MG00009	64	HEX NYLON LOCK NUT 1/4-20UNC	2
MG00011	65	RIBBED HEX NUT 1/4-20UNC	1
MF00020	66	HEX HEAD BOLT 3/8-16UNC x 1-1/4" (Full thread)	6
MG00016	70	#10 FLAT WASHER	1
MG00017	71	1/4" FLAT WASHER	4
MG00018	72	LOCK WASHER 3/8"	10
MK00004	75	LIMIT SWITCH (STANDARD)	4
ME00018	77	KEYWAY 3/16 SQ. x 1-1/4" LONG	1
MG00010	78	RIBBED HEX NUT 10-32 UNF	4
ME00006	80	INTERMEDIARY SHAFT (PRO-HHD/GT) 1" x 10-7/16"	1
ME00055	84	KEYSTOCK 3/16" x 1-3/4" LONG	2
ME00050	141	FRAME SUPPORT SHAFT 3/4" x 6" LONG	1
MG00042	142	LOCK WASHER 5/16"	4
MX00031	160	IN-LINE TORQUE CLUTCH ASSEMBLY	1
MM00198	161	CLUTCH COVER (MSI0199)	1
ME00051	162	IN-LINE CLUTCH SUPPORT SHAFT	4
MG00093	179	FLAT WASHER #8	4

MS100-WW 1-Phase Wiring Diagram

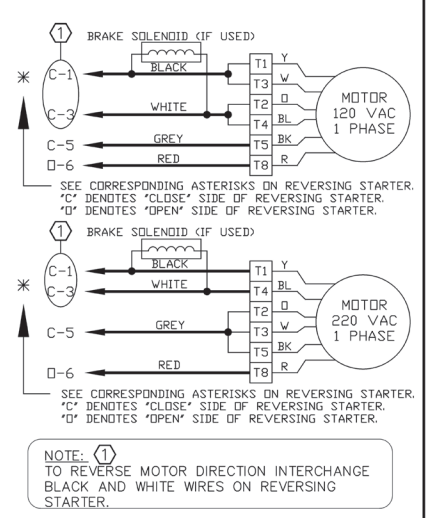

FOR 220V REMOVE BLACK WIRE FROM C6 AND PLACE ON O4
 JUMPER NOT REQUIRED (PLEASE REMOVE)
 NOTE:
 - MOTOR RELAY (M), TRANSFORMER AND SOLENOID (IF APPLICABLE) MUST BE 220V.
 - CIRCUIT BREAKER MUST BE APPROPRIATE AMPERAGE.
 - MOTOR MUST BE WIRED FOR 220V AS SHOWN ABOVE .

IF STOP BUTTON NOT USED, ADD JUMPER BETWEEN 2 & 3.

TIME DELAY UPON REVERSE (OPTIONAL)
 IF 1.5 SEC TIME-DELAY UPON SAFETY REVERSE IS REQUIRED. REMOVE THE PURPLE WIRE FROM TERMINAL #4, AND CONNECT TO ONE END OF TIME-DELAY AND OTHER END, BACK TO TERMINAL #4.

NOTE: C2 / B2 CONTROL WIRING OPTION ON CLOSE.
 C2 THIS OPERATOR LEAVES THE FACTORY WITH A "C2" WIRING - MEANING THAT CONSTANT PRESSURE IS REQUIRED TO CLOSE THE DOOR.
 B2 IF MOMENTARY OPERATION ON CLOSE ("B2" WIRING) IS DESIRED, THEN REMOVE THE WHITE WIRE FROM TERMINAL #5 AND PLACE IT ON TERMINAL #3.

WARNING
 NICE STRONGLY RECOMMENDS THE USE OF ENTRAPMENT PROTECTION SYSTEMS WHEN B2 (MOMENTARY CONTACT) WIRING IS USED.

NOTE: MINIMUM 18 AWG WIRE MUST BE USED FOR FIELD CONNECTIONS.

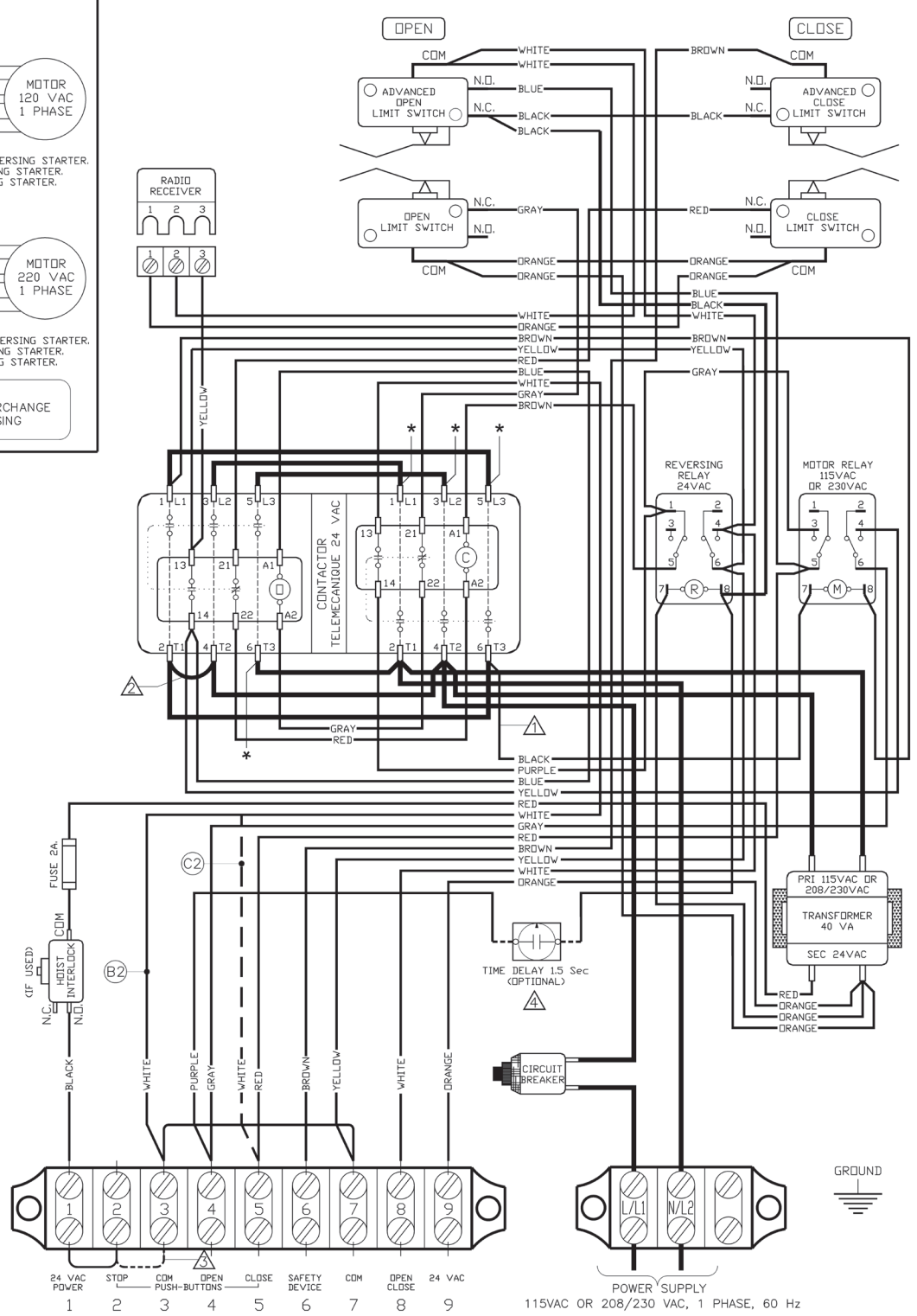

1-Phase Wiring Diagram
 MS100-WW
 REV. J DATE: 20.02.20
 TECH. HELP LINE:
 CANADA: 1-(877) 888-1116
 USA: 1-(888) 816-8584

Nice
 Nice Group Canada Inc.
 1380 St Regis Blvd, Dorval, QC H9P 2T5

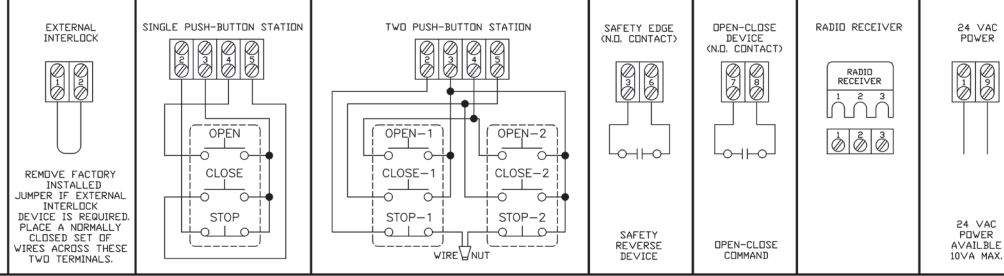

This drawing is strictly confidential and reserved by law. The total or partial reproduction without authorization is prohibited/forbidden

MS100-IM-WW 1-Phase Wiring Diagram

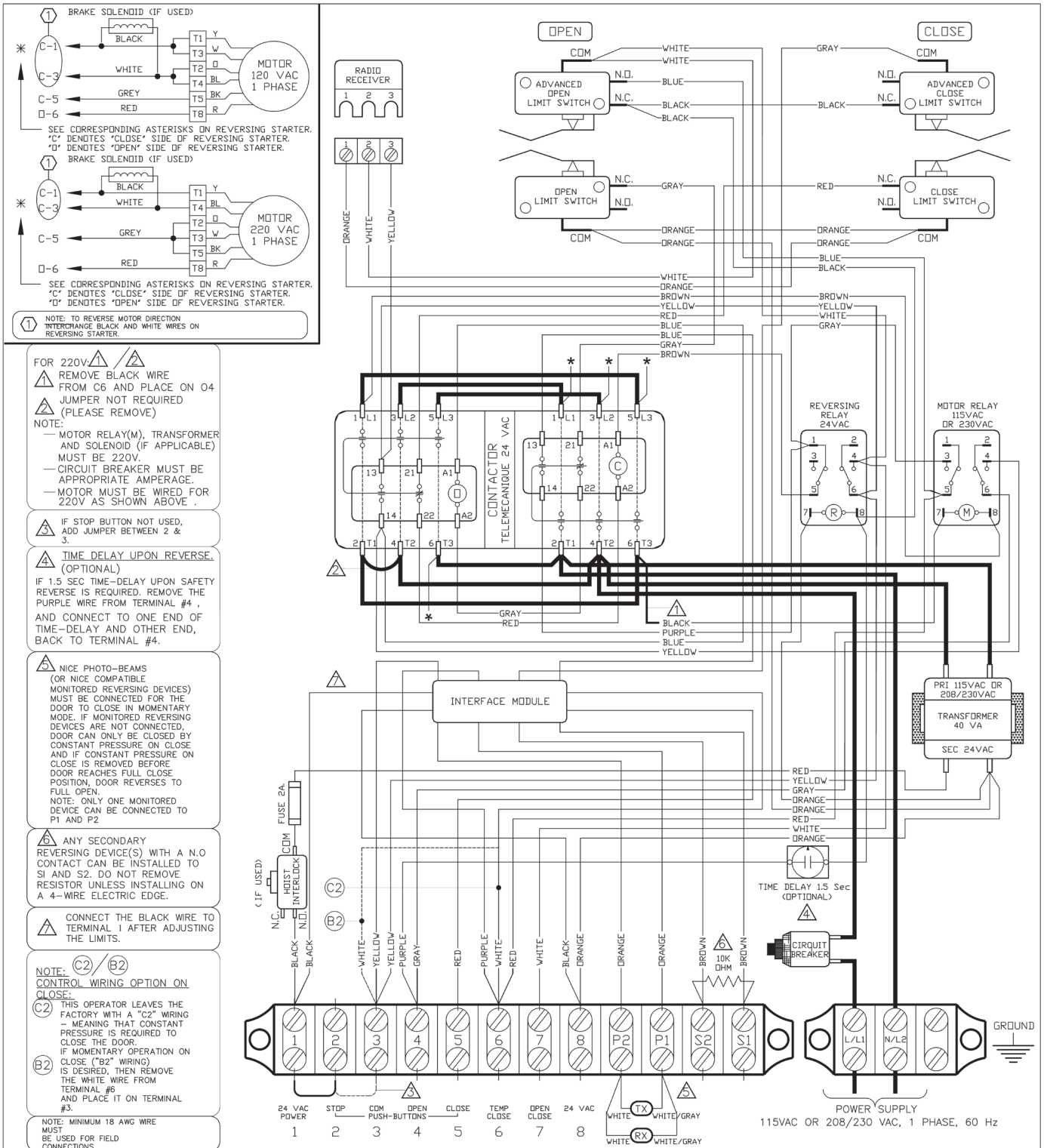

1-Phase Wiring Diagram
MS100-IM-WW
 REV. J DATE: 03.12.20
 TECH. HELP LINE:
 CANADA: 1-(877) 888-1116
 USA: 1-(888) 816-8584



Nice Group Canada Inc.
 1380 St Regis Blvd, Dorval, QC H9P 2T5

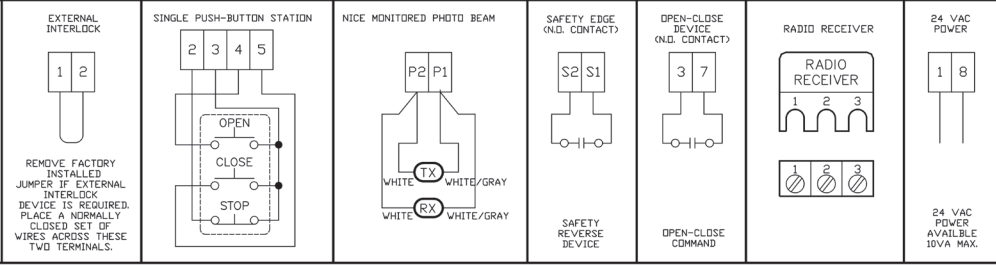

This drawing is strictly confidential and reserved by law. The total or partial reproduction without authorization is prohibited/forbidden

MSL100-110V-WW 1-Phase Wiring Diagram

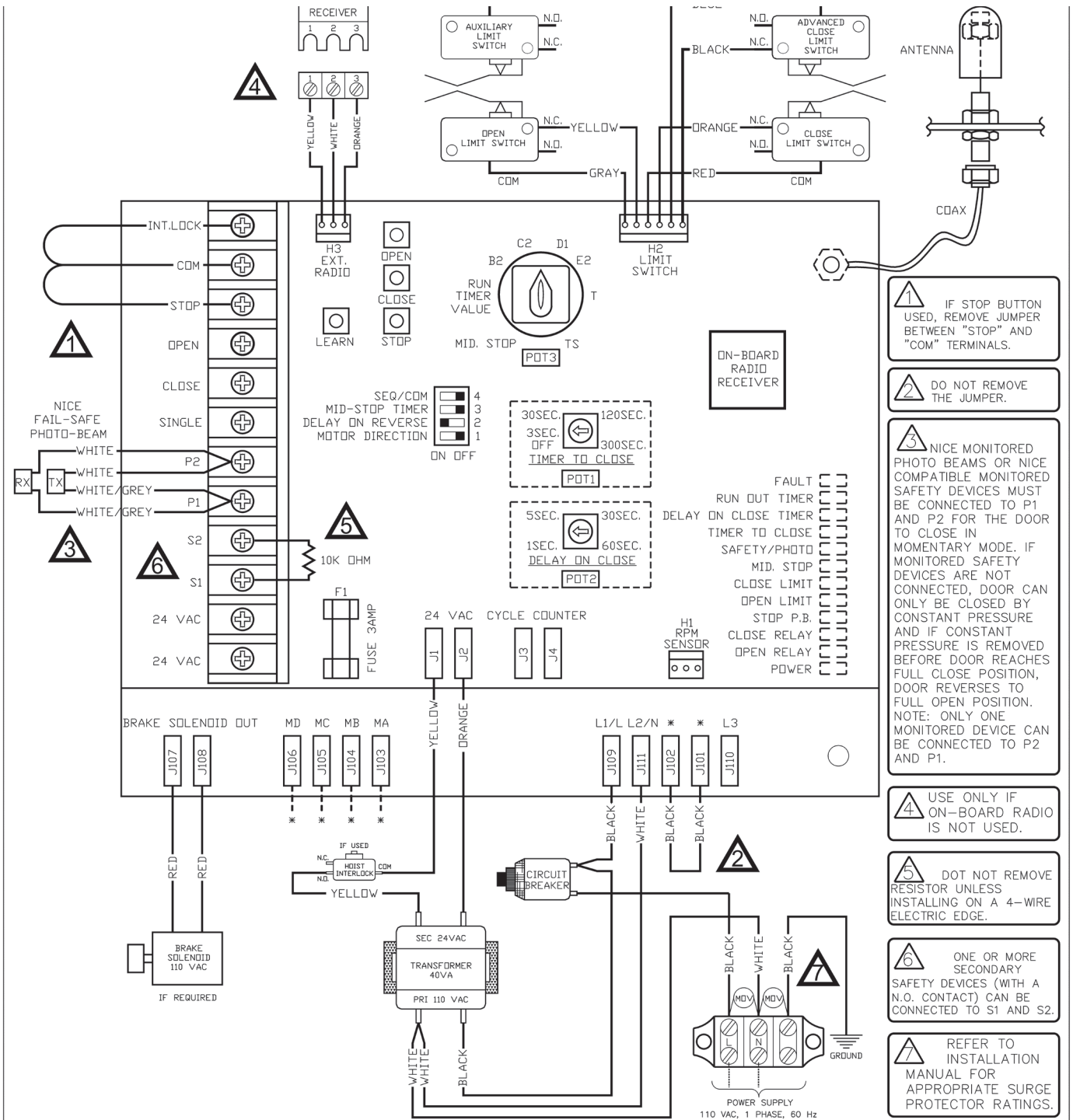

1 IF STOP BUTTON USED, REMOVE JUMPER BETWEEN "STOP" AND "COM" TERMINALS.

2 DO NOT REMOVE THE JUMPER.

3 NICE MONITORED PHOTO BEAMS OR NICE COMPATIBLE MONITORED SAFETY DEVICES MUST BE CONNECTED TO P1 AND P2 FOR THE DOOR TO CLOSE IN MOMENTARY MODE. IF MONITORED SAFETY DEVICES ARE NOT CONNECTED, DOOR CAN ONLY BE CLOSED BY CONSTANT PRESSURE AND IF CONSTANT PRESSURE IS REMOVED BEFORE DOOR REACHES FULL CLOSE POSITION, DOOR REVERSES TO FULL OPEN POSITION. NOTE: ONLY ONE MONITORED DEVICE CAN BE CONNECTED TO P2 AND P1.

4 USE ONLY IF ON-BOARD RADIO IS NOT USED.

5 DO NOT REMOVE RESISTOR UNLESS INSTALLING ON A 4-WIRE ELECTRIC EDGE.

6 ONE OR MORE SECONDARY SAFETY DEVICES (WITH A N.O. CONTACT) CAN BE CONNECTED TO S1 AND S2.

7 REFER TO INSTALLATION MANUAL FOR APPROPRIATE SURGE PROTECTOR RATINGS.

1-Phase Wiring Diagram 110V
MSL100-110V-WW
REV. E | DATE: 20.02.20
TECH. HELP LINE:
CANADA: 1-(877) 888-1116
USA: 1-(888) 816-8584

Nice
Nice Group Canada Inc.
1380 St Regis Blvd, Dorval, QC H9P 2T5

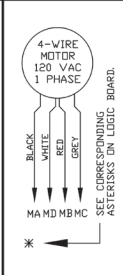
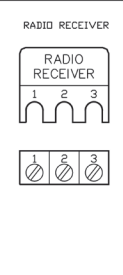
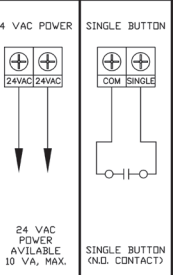
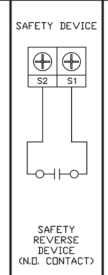
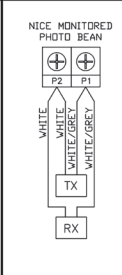
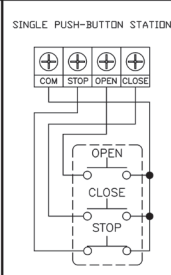
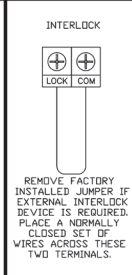

This drawing is strictly confidential and reserved by law. The total or partial reproduction without authorization is prohibited/forbidden

MSL100-220V-WW 1-Phase Wiring Diagram

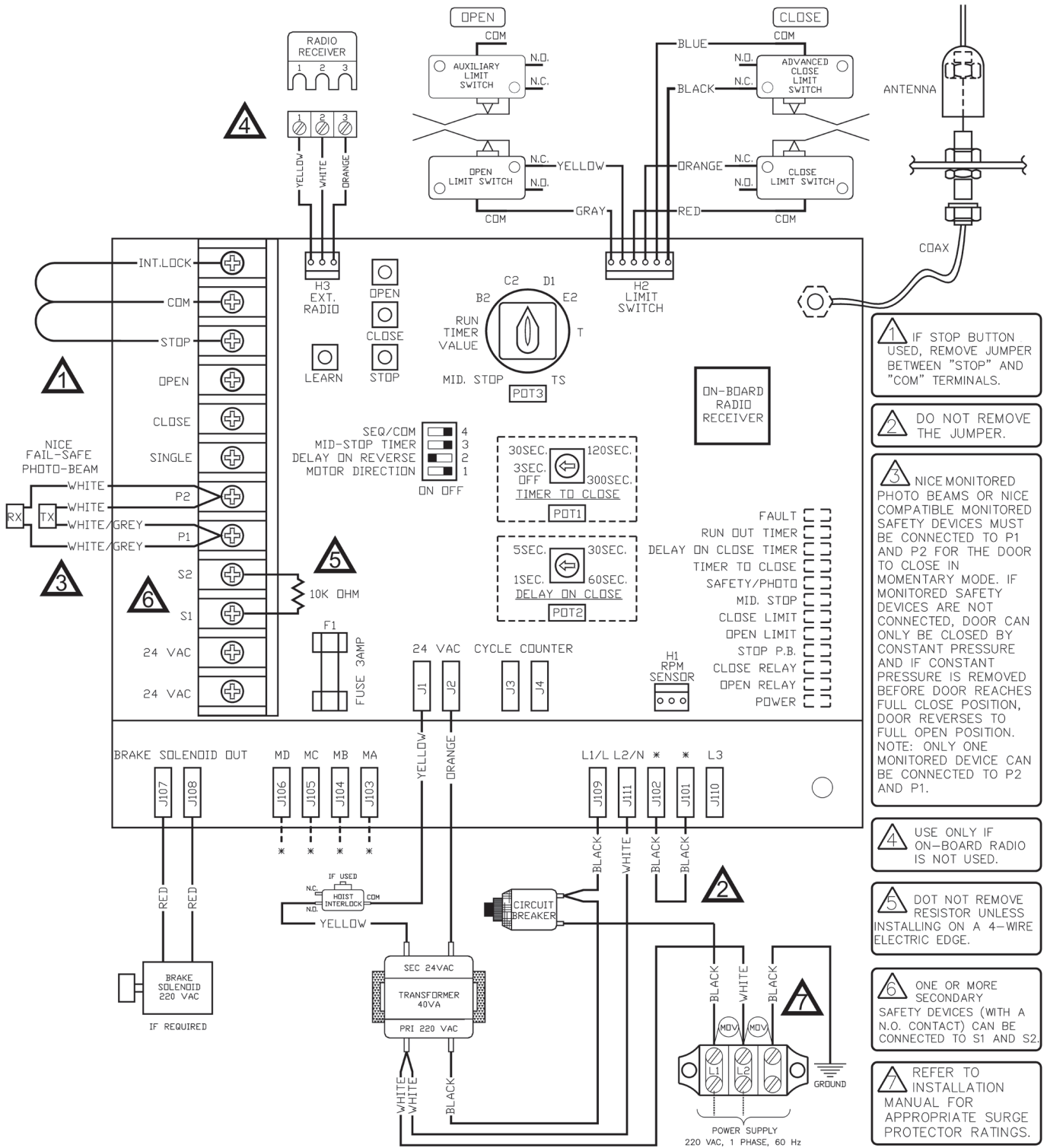

1 IF STOP BUTTON USED, REMOVE JUMPER BETWEEN "STOP" AND "COM" TERMINALS.

2 DO NOT REMOVE THE JUMPER.

3 NICE MONITORED PHOTO BEAMS OR NICE COMPATIBLE MONITORED SAFETY DEVICES MUST BE CONNECTED TO P1 AND P2 FOR THE DOOR TO CLOSE IN MOMENTARY MODE. IF MONITORED SAFETY DEVICES ARE NOT CONNECTED, DOOR CAN ONLY BE CLOSED BY CONSTANT PRESSURE AND IF CONSTANT PRESSURE IS REMOVED BEFORE DOOR REACHES FULL CLOSE POSITION, DOOR REVERSES TO FULL OPEN POSITION. NOTE: ONLY ONE MONITORED DEVICE CAN BE CONNECTED TO P2 AND P1.

4 USE ONLY IF ON-BOARD RADIO IS NOT USED.

5 DO NOT REMOVE RESISTOR UNLESS INSTALLING ON A 4-WIRE ELECTRIC EDGE.

6 ONE OR MORE SECONDARY SAFETY DEVICES (WITH A N.O. CONTACT) CAN BE CONNECTED TO S1 AND S2.

7 REFER TO INSTALLATION MANUAL FOR APPROPRIATE SURGE PROTECTOR RATINGS.

1-Phase Wiring Diagram 220V
MSL100-220V-WW
REV. E | DATE: 20.02.20
TECH. HELP LINE:
CANADA: 1-(877) 888-1116
USA: 1-(888) 816-8584



Nice Group Canada Inc.
1380 St Regis Blvd, Dorval, QC H9P 2T5

<p>INTERLOCK</p> <p>REMOVE FACTORY INSTALLED JUMPER IF EXTERNAL INTERLOCK DEVICE IS REQUIRED. PLACE A NORMALLY CLOSED SET OF WIRES ACROSS THESE TWO TERMINALS.</p>	<p>SINGLE PUSH-BUTTON STATION</p>	<p>NICE MONITORED PHOTO BEAN</p>	<p>SAFETY DEVICE</p> <p>SAFETY REVERSE DEVICE (N.O. CONTACT)</p>	<p>24 VAC POWER</p> <p>24 VAC POWER AVAILABLE 10 VA, MAX.</p>	<p>SINGLE BUTTON</p> <p>SINGLE BUTTON (N.O. CONTACT)</p>	<p>RADIO RECEIVER</p>	<p>4-WIRE MOTOR 220 VAC 1 PHASE</p> <p>SEE CORRESPONDING PAGES ON LOGIC BOARD.</p>
--	-----------------------------------	----------------------------------	--	---	--	-----------------------	--

MSLC100-WW 1-Phase Wiring Diagram

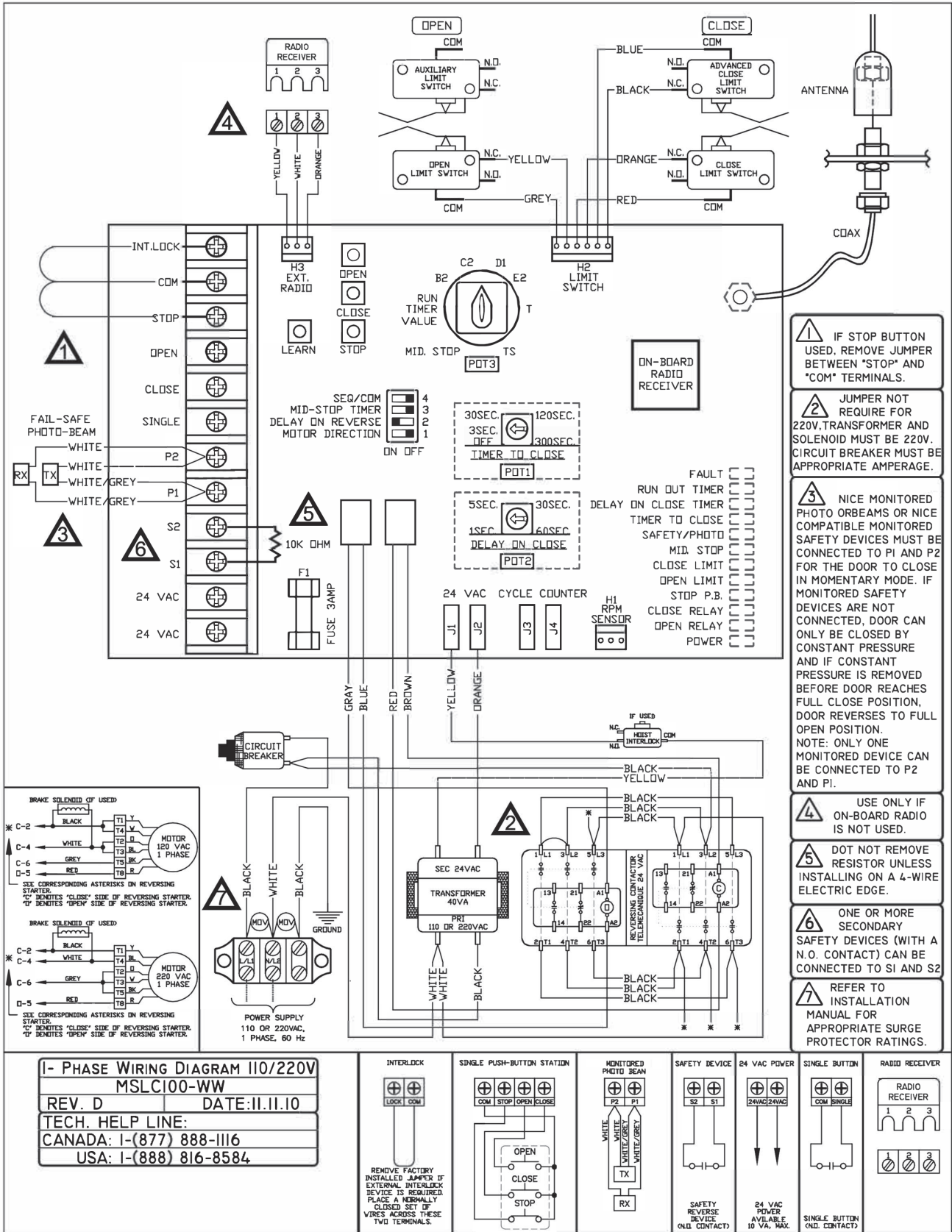

MS300-WW 3-phase Wiring Diagram

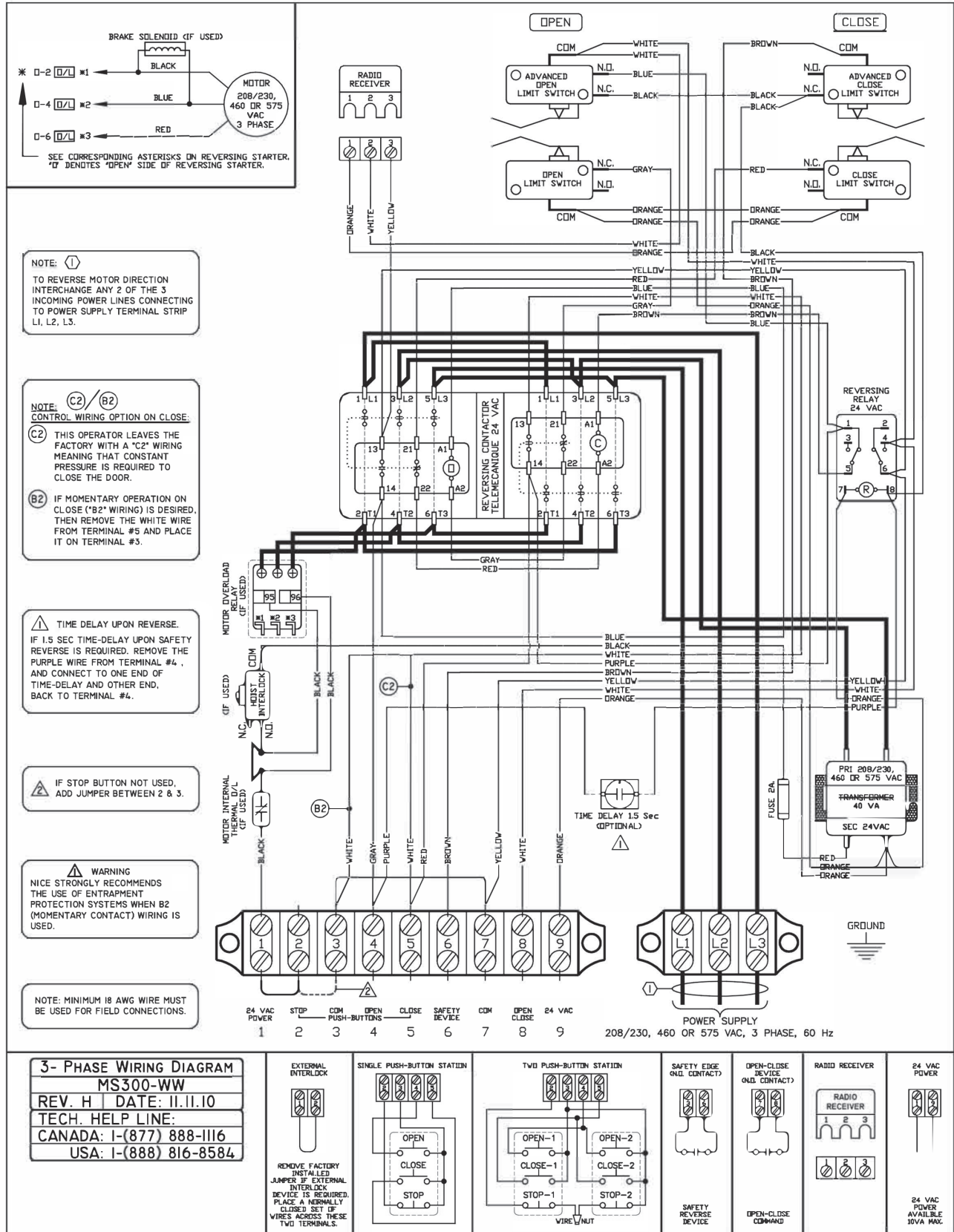

MS300-IM-WW 3-Phase Wiring Diagram

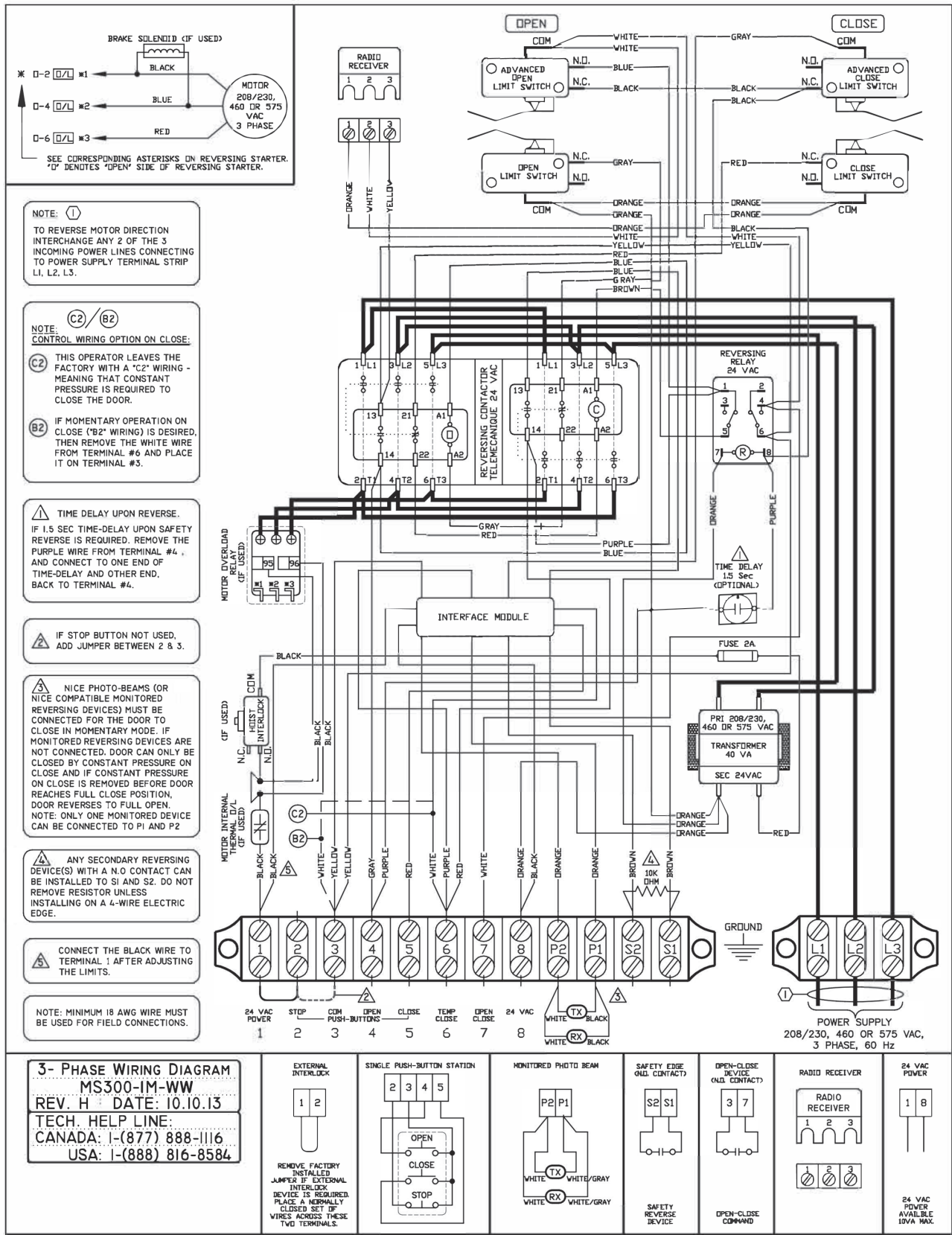

MSL300-WW 3-Phase Wiring Diagram

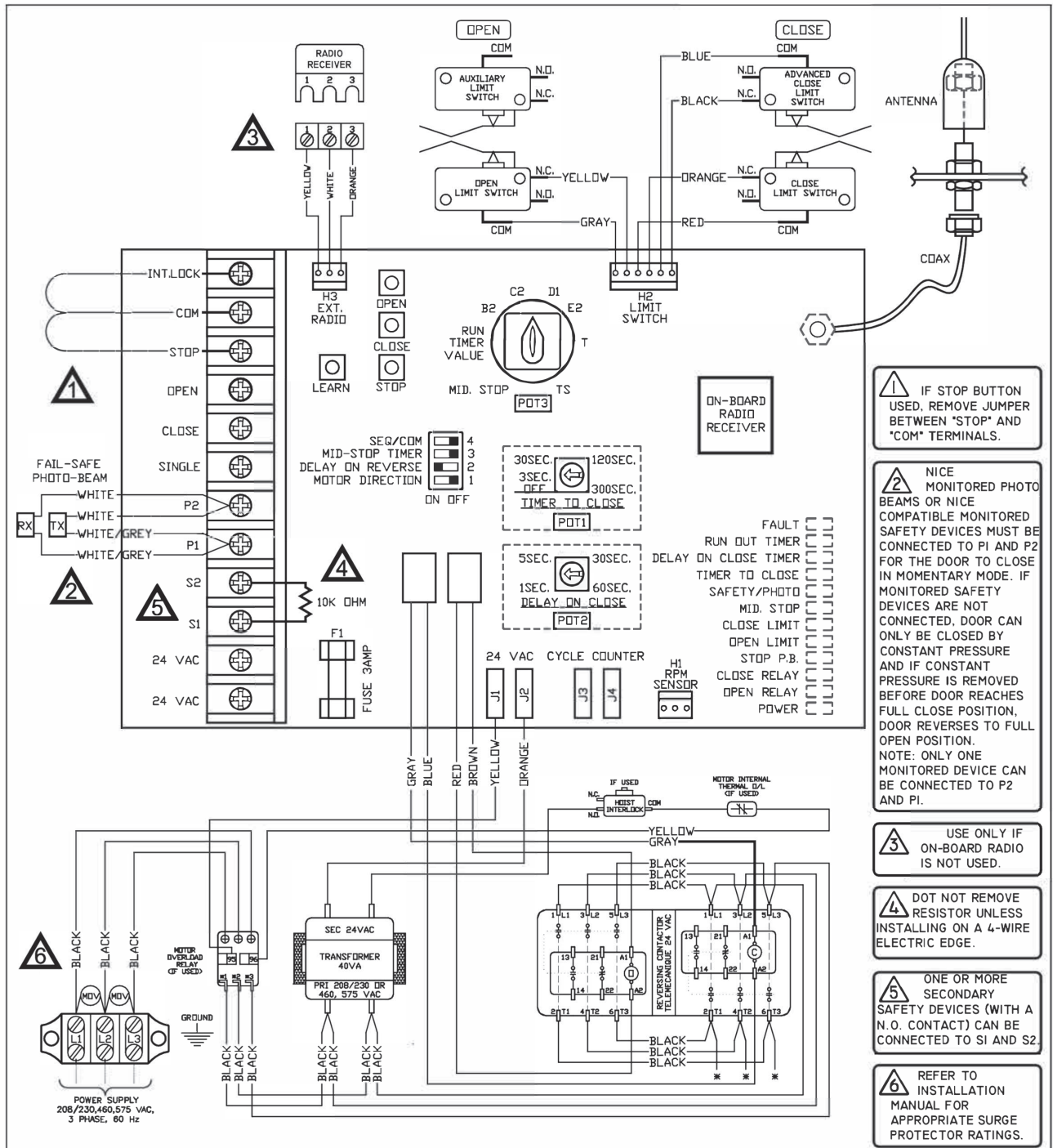

3- PHASE WIRING DIAGRAM
MSLC300-WW
 REV. F DATE: II.II.10
 TECH. HELP LINE:
 CANADA: 1-(877) 888-1116
 USA: 1-(888) 816-8584

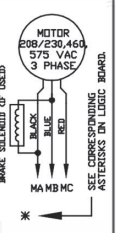
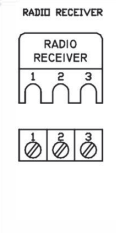
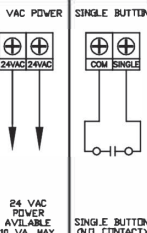
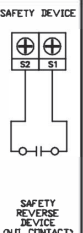
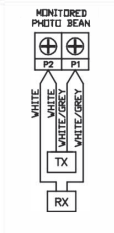
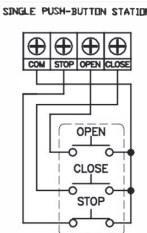
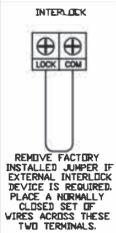

Technical Support:

877-888-1116

Technical Support Hours:

M – F, 8:00 a.m. – 6:00 p.m. ET

Nice North America

c/o Customer Service

5919 Sea Otter Place, Suite 100

Carlsbad, CA 92010



Niceforyou.com

©2024 Nice North America LLC.
All rights reserved.