

Pro-GJ

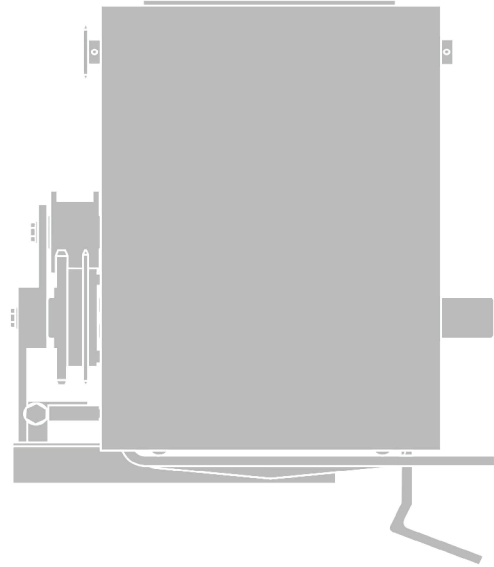

Automation for sectional and rolling doors

Instructions and warnings for installation and use

Nice

Contents

Warranty	3
Verification of Operator and Hardware	4
PRO-GJ Specifications	5
Important Safety Instructions	6
Important Installation Instructions	6
Installation Instructions	7
Electrical Connections	10
SECTION A: PRO-GJ Standard Relay Logic Controls	11
Connection of Power Supply and Control Station	11
Limit Switch Adjustment	11
Connection of a Reversing Edge Device and Control Accessories.	12
SECTION B: PRO-GJ(M) Relay Logic Controls with Interface Module	13
Connection of Power Supply and Control Station	13
Operator Electrical Connections and Start-up Instructions	13
Important: Follow these steps carefully and in the order shown:	13
SECTION C: PRO-GJ(E) Limited Duty Smart 5.0 logic board	16
Connection of External Single-Button Device	18
Modes of Operation	18
Timer to Close Setup	19
SECTION D: For all Operator Control Types	20
Limit Switch Adjustment	20
SECTION E: For Operators with Interface Modules or Logic boards	21
Installation of Nice N-1 or N-4 Photocells	21
Installation Safety Precautions	21
Wall Installation:	21
NICE N-4 Photocell (MK00650)	22
Wall installation	22
For Nice Nema-1 and Nema-4 photobeams	23
FRABA N-4/4 Thru-Beam Photocell (MK00697)	24
Mechanical External Load Sensing Adjustment	25
Adjustment Conditions	25
Emergency Manual Operation	26
Operator Maintenance	27
Limited Gearhead Operator PRO-GJ Parts Diagram	28
Gearhead Operator Pro-GJ Parts List	29
MSLT/GJ-WW 1-Phase Wiring Diagram	30
MSLT/GJ2-WW 1-Phase Wiring Diagram	31
MS300LH-WW 3-Phase Wiring Diagram	32
MSLGJ-IM-WW 1-Phase Wiring Diagram	33
MSGJ2-IM-WW Wiring Diagram	34
MS300LH-IM-WW 3-Phase Wiring Diagram	35
MSLLHR110V-WW 1-Phase Wiring Diagram	36
MSLLHR220V-WW 1-Phase Wiring Diagram	37
Notes	38

Warranty

Nice North America warrants that materials and workmanship are free from defects for a period of four (4) years or 50,000 cycles, whichever comes first. The start of the warranty will be determined by the date of invoice. Materials returned to Nice deemed defective after examination will be returned at the option of Nice with repaired, new, or re-manufactured parts.

Nice North America will not be responsible for any charges incurred in the process of returning defective material. All returned material must be received pre-paid, or it will not be accepted.

This warranty is limited, and in lieu of all other warranties expressed or implied. There is no expressed liability due on the part of the seller.

MP00024	Chain Spreader
MP00001	Timer to Close
MP00069-74	Auxiliary Trolley C/W Track & #41 Chain
MX00001	Floor Level Disconnect in Lieu of Chain Keeper
MP00086	Fire Release Mechanism PRO-GJ
MM00319	PRO-GJ Hood Mount Bracket
MP00107	PRO-GJ mechanical external load sensing

WARNING







DO NOT CONNECT TO ELECTRICAL POWER DURING
INSTALLATION OR SERVICING OF OPERATOR.

Verification of Operator and Hardware

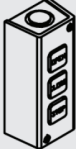
IMPORTANT

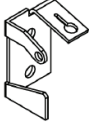
FOR ANY QUESTIONS CONCERNING THE SAFETY OR OPERATION OF THIS OPERATOR, PLEASE CONTACT NICE AT 1-877-888-1116. SAVE THESE INSTRUCTIONS.

Upon delivery of your Nice medium duty gearhead jackshaft door operator, please inspect the unit carefully for damage. Verify that operator horsepower, voltage, phase and amperage correspond to available power supply and door application. Check that along with your operator you have received the following standard hardware.

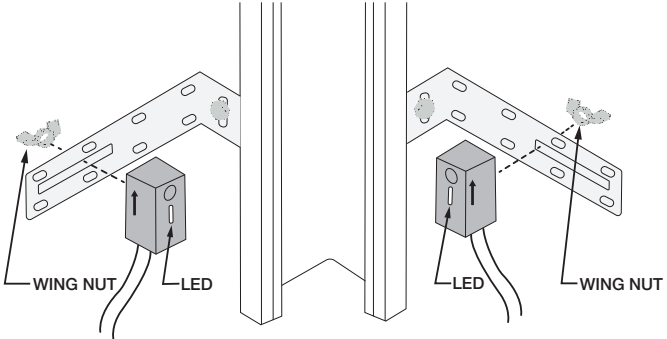
1 x OPEN/CLOSE/STOP 3-Button Control Station	
1 x #41 Drive chain package: 4' (1.2m) c/w #41 connecting link	
1 x Door Sprocket: 41B32 x 1" c/w 2 set screws and 1/4" x 1-1/4" keyway NOTE: Sprocket size and bore may vary according to door size and type, shaft size and drum diameter.	
1 x Chain Keeper	
1 x Keyring	
4 x 3/8" bolt, hex nut, lock washer and flat washer	
1 x Warning Sign	
1 set of Nice photocells (supplied when operator ordered with interface module)	

PRO-GJ Specifications

PRO-GJ medium duty gearhead jackshaft operators are designed for small commercial and industrial doors and rolling grilles provided that doors are driven by a drive shaft.

Standard Operator Weight	PRO-GJ (55-65 lbs)		
Motor	Intermittent duty 1050 RPM motor with high starting torque. Thermally protected by a built-in thermostat that cuts power to the motor and control circuit when overheating.		
Horsepower	1/2 HP		
Voltage	115V 1-phase (60Hz)	230V 3-phase (60Hz)	220V 1-phase (50Hz)
	230V 1-phase (60Hz)	460V 3-phase (60Hz)	380V 3-phase (50Hz)
		575V 3-phase (60Hz)	
Reduction	Primary: Heavy duty worm gear reducer 45:1 reduction		
	Secondary: #41 chain and sprockets from operator to door shaft		
Output Shaft Speed	24 RPM		
Wiring Type (3 Options)	Option 1: Limited Duty logic board Smart 5.0 (UL325 (2010) compliant). NOTE: Nice compatible primary entrapment device must be connected for B2 or TS (momentary or timer activation on close) feature.		
	Option 2: Relay logic controls with Interface Module (UL325 (2010) compliant). C2 Standard factory wiring (constant pressure on close, momentary contact on open and stop). If momentary contact on close (B2) wiring is desired, connect loose "purple" wire to terminal #5. NOTE: Nice compatible primary entrapment device must be connected for B2 (momentary activation on close) feature.		
	Option 3: Standard relay logic controls (not UL325 (2010) compliant, not available in US or Canada) C-2 Wiring constant pressure on close, momentary contact on open and stop. NOTE: If momentary contact on close (B2) wiring is desired, connect loose "purple" wire to terminal #5.		
Transformer	24VAC control circuit, supplies power to drive control relays with 15VA power available for external devices.		
Limit Adjustment	4 micro switches that control door travel. These limit switches are activated by fully adjustable screw type cams.		
Emergency Disconnect	Floor level cable disconnect system allows person to manually operate door manually in case of emergency.		
Operator Dimensions:			

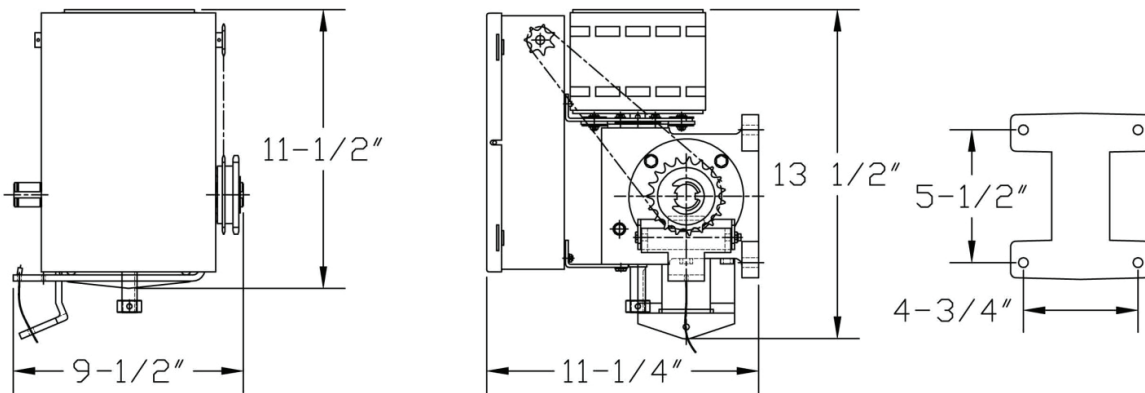

Important Safety Instructions

WARNING: To reduce the risk of injury or death:

- READ AND FOLLOW ALL INSTRUCTIONS
- Never allow children to operate or play with door controls. Keep the remote control (where provided) away from children.
- Personnel should keep away from a door in motion and keep the moving door in sight until it is completely closed or opened. **NO ONE SHOULD CROSS THE PATH OF A MOVING DOOR.**
- Test the door's safety features at least once a month. After adjusting the limit of travel, retest the door operator's safety features. Failure to adjust the operator properly may cause severe injury or death.
- For products having a manual release, if possible, use the manual release only when the door is closed. Use caution when using this release when the door is open. Weak or broken springs may cause the door to fall rapidly, causing severe injury or death.
- **KEEP DOORS PROPERLY OPERATING AND BALANCED.** See Door Manufacturer's Owner's Manual. An improperly operating or balanced door could cause severe injury or death. Have trained door systems technician make repairs to cables, spring assemblies, and other hardware.
- Press the "OPEN" device or use emergency disconnect mechanism if a person is trapped under the door.
- **SAVE THESE INSTRUCTIONS.** The owner or users must understand the safety and operation of door system. Insure that this installation manual be located close to the door system.

Important Installation Instructions

- READ AND FOLLOW ALL INSTALLATION INSTRUCTIONS
- Commercial door operators are never to be installed on a residential installation
- Install only on a properly operating and balanced door. A door that is operating improperly could cause severe injury. Have qualified service personnel make repairs to cables, spring assemblies, and other hardware before installing the operator.
- Remove all pull ropes and remove, or make inoperative, all locks (unless mechanically and/or electrically interlocked to the power unit) that are connected to the door before installing the operator.
- Install the door operator at least 8 feet or more above the floor if the operator has exposed moving parts.
- Do not connect the operator to the source of power until instructed to do so.
- Locate the control station: (a) within sight of the door, (b) at a minimum height of 5 feet so that small children cannot reach it, and (c) away from all moving parts of the door.
- Install the Entrapment Warning Placard next to the control station in a prominent location.
- For products having a manual release, instruct the end user on the operation of the manual release.
- Install non-contact entrapment protection devices (photocells) and/or contact entrapment protection devices (reversing edges). **NOTE:** photocells should be installed at no more than 6" from the floor. Edges should be installed on the leading edge of the door.

Installation Instructions

⚠ WARNING ⚠

DO NOT INSTALL THIS OPERATOR BEFORE READING THIS MANUAL CAREFULLY.

NOTE:

- Installation of operator must be done by a qualified installer. Door must be properly installed and working smoothly. Remove all door locks prior to installation.
- For the PRO-GJ operators **the handing of the operator must be stated at time of order**. If operator is not the correct handing: Remove c-clips, drive sprocket, coupling, spring and disconnect components and install on opposite side of reducer. Remove limit chain, limit shaft and limit sprocket and install on opposite side of limit box. (Refer to drawing below as well as the exploded view diagram at the end of this manual).

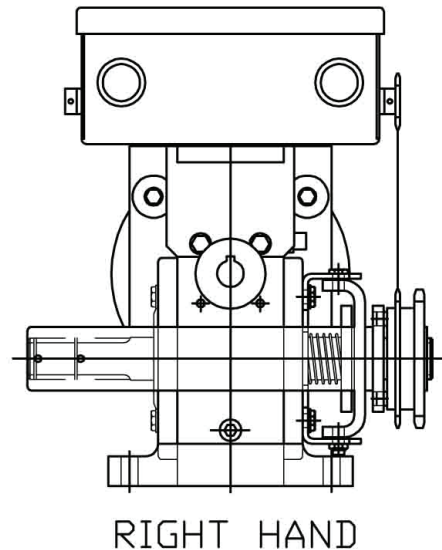
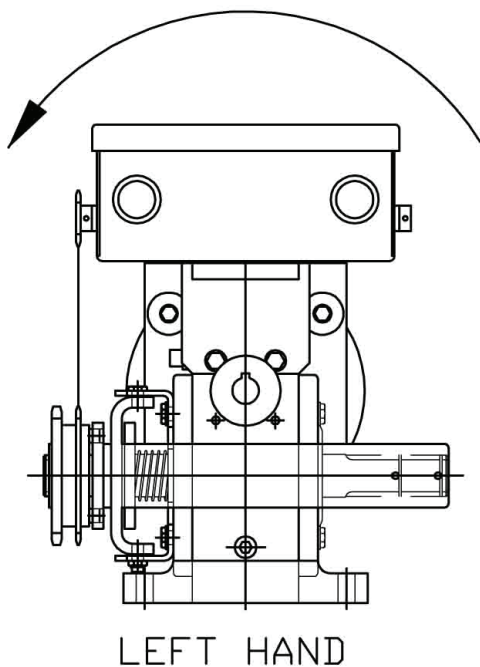

1. Install control station away from all moving door parts, within sight of the door and a minimum of 5 ft (1.5 m) from the ground.
2. Install entrapment warning sign next to control station.

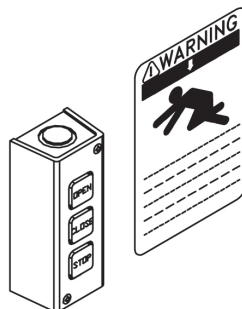

- As a general rule, the door operator should be installed below the drive shaft and as close to the door as possible. The ideal distance between the operator drive shaft and the door shaft is approximately 12" (30cm) to 15" (38cm). The operator may be wall/bench mounted or bracket /shelf mounted. These two mounting configurations are shown below:

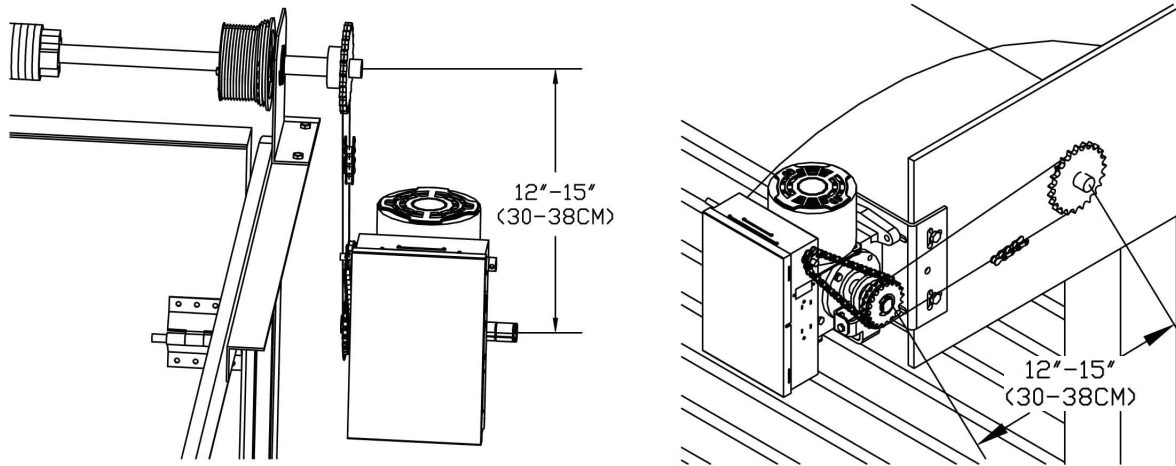

- Mount the operator to the wall, hood or bench with 3/8" bolts, nuts and washers provided or with lag bolts and shields if installation requires it. Make sure that operator is secured but do not tighten bolts.
- Place door sprocket on door shaft and align with operator drive sprocket but do not insert keyway or set screws.
- If an optional chain spreader has been ordered with your operator, install as shown below:

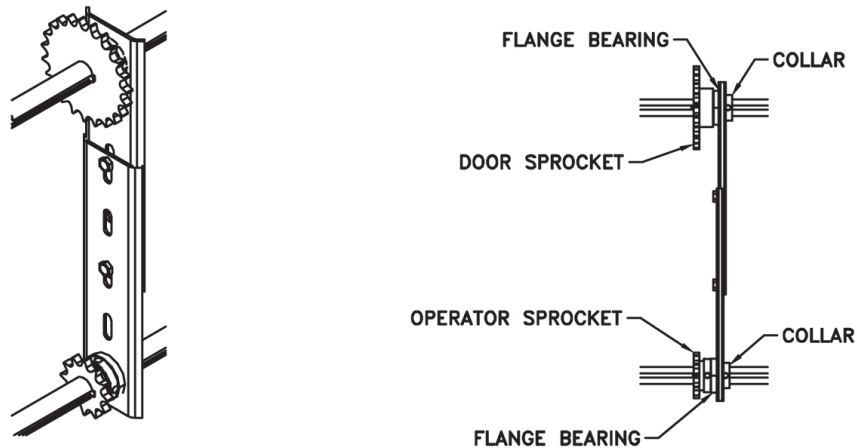

- Install drive chain over sprockets, cut to a suitable length and connect with connecting link.
- Lower or raise operator to adjust chain tension so that there is no more than 1/4" chain slack between sprockets. Tighten operator mounting bolts.
- Carefully re-align sprockets, if necessary and secure keyway and set screws.

10. Install chain keeper to wall below operator at approximately 4' from floor. Run disconnect chain through keyhole of chain keeper and cut excess chain links if required. Attach keyring to end of disconnect chain.

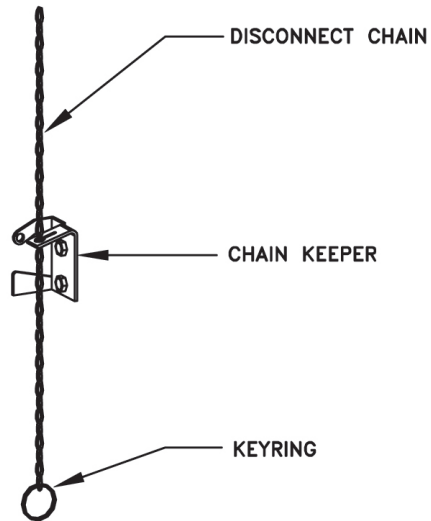

12. If an **optional** floor level disconnect lever was ordered in lieu of the chain keeper, mount to wall with suitable hardware. Attach both chains together using keyring provided. Allow disconnect chain to be slightly slack when lever is in the up position.



13. **IMPORTANT:** After installation is complete, remove red activation pin on reducer breather plug.

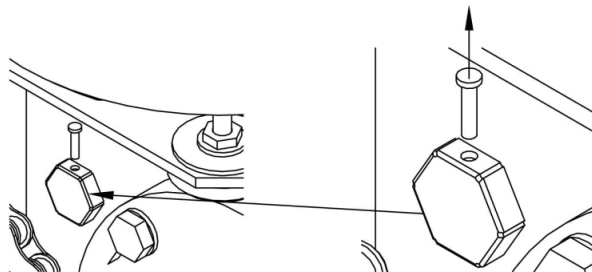

Electrical Connections

These are 3 possible electrical control configurations for this operator:

- A) **Standard relay logic controls (not UL325 (2010) compliant, not available in US or Canada).** Refer to Section A for electrical connections. Refer to electrical drawings inside your operator control box or generic drawings MSLT/GJ-WW, MSLT/GJ2-WW or MS300LH-WW in the electrical drawings section at the end of this manual.
- B) **Relay logic controls with Interface Module (UL325 (2010) compliant).** Refer to Section B for electrical connections. Refer to electrical drawings inside your operator control box or generic drawings MSLT/GJ-IM-WW or MSLT/GJ2-IM-WW or MS300LH-IM-WW in the electrical drawings section at the end of this manual.
- C) **Limited duty logic board Smart 5.0 (UL325 (2010) compliant).** Refer to Section C for electrical Connections and logic board instructions. Refer to electrical drawings inside your operator control box or generic drawings MSLHR-WW or MSLHR220-WW, in the electrical drawings section at the end of this manual.

IMPORTANT

- NICE HIGHLY RECOMMENDS THAT EACH INDIVIDUAL COMMERCIAL DOOR OPERATOR HAVE IT'S OWN DEDICATED POWER SUPPLY
- NICE HIGHLY RECOMMENDS THAT EACH INDIVIDUAL COMMERCIAL DOOR OPERATOR HAVE AN EXTERNAL CIRCUIT BREAKER OR FUSED DISCONNECT

⚠ WARNING ⚠

COMPARE AVAILABLE POWER SUPPLY VOLTAGE TO OPERATOR NAMEPLATE PRIOR TO ELECTRICAL CONNECTION. FAILURE TO CONNECT APPROPRIATE POWER SUPPLY VOLTAGE MAY CAUSE SERIOUS DAMAGE TO OPERATOR.

Refer to electrical diagrams inside control box cover or at the end of this manual prior to connection of power supply or control station.

⚠ WARNING ⚠

TO REDUCE THE RISK OF INJURY OR DEATH:

ALL ELECTRICAL CONNECTIONS SHOULD BE MADE BY A QUALIFIED SERVICE PERSON
DO NOT ATTEMPT TO MAKE ELECTRICAL CONNECTIONS TO OPERATOR UNLESS POWER SUPPLY HAS BEEN DISCONNECTED AT FUSE BOX.

OPERATOR MUST BE CONNECTED IN ACCORDANCE TO LOCAL ELECTRICAL CODES AND GROUNDED TO GREEN GROUND LUG LOCATED INSIDE CONTROL BOX.

SECTION A: PRO-GJ Standard Relay Logic Controls

(not UL325 (2010) Compliant, not available in US or Canada)

Connection of Power Supply and Control Station

POWER WIRING: Use 1-1/8" (2.85 cm) diameter holes for all power wiring.

1. **Single phase:** Connect single phase power supply to terminals L/L1 (line) and N/L2 on three-pole power terminal strip.
2. **Three-phase (for 1/2HP 230V, 460V, 575V 60Hz or 380V 50Hz):** Connect three phase power supply to terminals L1, L2 and L3 on three-pole power terminal strip.

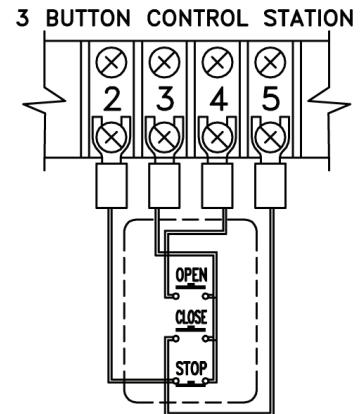
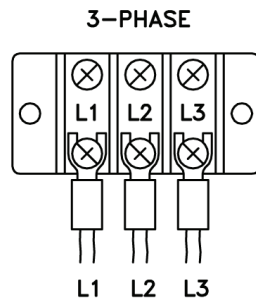
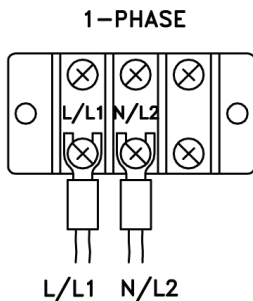

CONTROL WIRING: Use 7/8" (2.22 cm) diameter holes for all control wiring.

NOTE: Do not run control wires and power wires in same conduit.

- Install control station within clear sight of door but away from all moving parts of door or hardware. Install Entrapment warning sign next to control station. Connect 3-button (open/close/stop) push button station to terminals 2, 3, 4 and 5. Refer to electrical diagram for connection of two 3-button stations.

NOTE: After electrical connections are made, manually move door to mid-position and, using the control station press the "Open" button for several seconds and then press the "Stop" button. If door did not move in correct direction verify wiring control station.

For 3-phase operators, if door still moves in wrong direction reverse any two of the three incoming power supply leads to correct rotation.

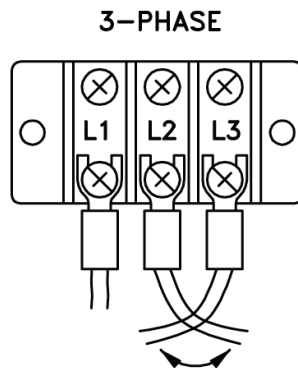

Limit Switch Adjustment

- Adjust Limit switches as explained in the "Limit switch adjustment section" further in this manual.

Connection of a Reversing Edge Device and Control Accessories

- Reversing Edge device** (must be normally open contact):

NOTE: If the door is controlled by any device or wired in such a manner that the door is not controlled by constant pressure on close then an appropriate reversing edge must be installed.

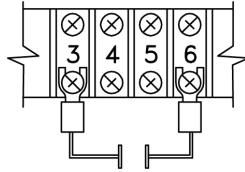

- External interlock:** Remove Jumper between terminals 1 and 2 and wire a N.C. interlock contact between these two terminals.

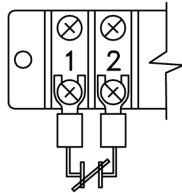

- Radio control receiver:** Wire standard radio receiver to separate radio strip on side of control box or to terminals 7, 8 and 9 on control terminal strip inside control box.

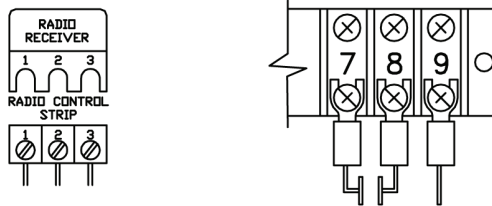

- Single button open/close device:** Wire to terminals 7 and 8 on control terminal strip.

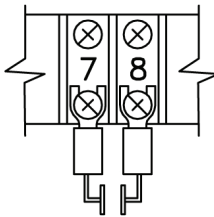

- Loop detectors, standard photocells (with a N.O. contact) and other reversing devices:** Wire to terminals 3 and 6 on control terminal strip.

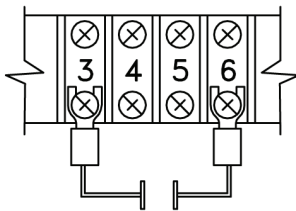

- 24 Volt power:** Wire to terminals 1 and 9 on control terminal strip

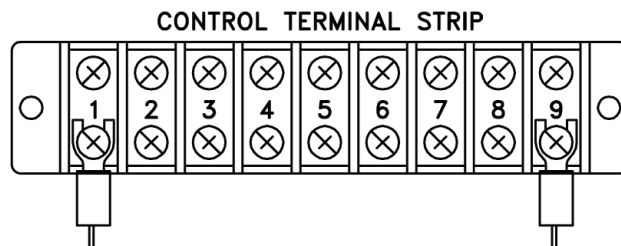

SECTION B: PRO-GJ(M) Relay Logic Controls with Interface Module

[UL325 (2010) Compliant]

Connection of Power Supply and Control Station

Operator Electrical Connections and Start-up Instructions

NOTE: THIS OPERATOR COMES WITH AN INTERFACE MODULE INTEGRATED INTO THE CONTROL CIRCUIT. THE PURPOSE OF THE INTERFACE MODULE IS TO ALLOW FOR FAILSAFE MONITORING OF A NICE COMPATIBLE SAFETY DEVICE AS PER UL 325 (2010) REQUIREMENTS.

Important: Follow these steps carefully and in the order shown:

1) Connect Power supply

Single Phase: Connect single phase power supply to terminals L/L1 and N/L2 on the 3-pole power terminals strip.

3-phase: Connect 3-phase power supply to terminals L1, L2 and L3 on the 3-pole power terminal strip.

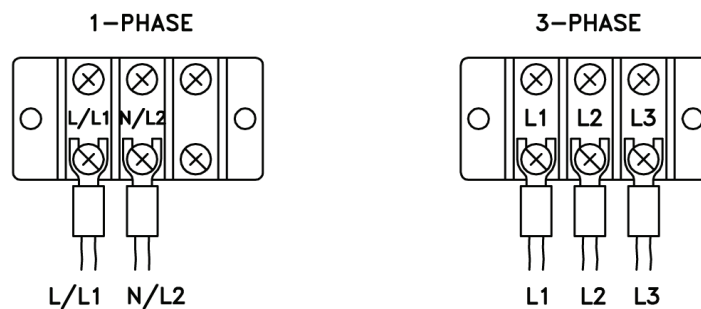

2) Connect Push-button station for installation purposes (single phase or 3-phase)

Connect open/close/stop push button station to terminals T2 (stop), T3 (common), T4 (open) and T6 (temporary CP on close).

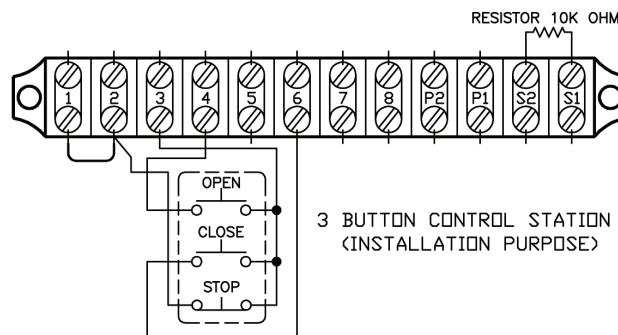

3) Verify Motor Direction

After the electrical power connections are made and push button station is connected, manually move the door to mid-position. Press Close button for several seconds and then press stop button. If door did not move in correct direction (or if limit cams not moving in correct direction towards the close limit switch) see below:

Single Phase Operators: The operators leave the factory with correct motor and limit shaft direction according to standard door installations. However, for special fire door, thru-wall mounting or other special door applications, the motor direction and limit switch direction may need to be reversed. To reverse the motor rotation, interchange Red and Yellow wires on the motor capacitor located in the control box.

3-phase operators (1/2 HP 230V, 460V, 575V 60 Hz or 380V 50Hz): If door moves in wrong direction, turn off incoming power and reverse any two of the three incoming power supply leads to correct rotation. Press the open button and then activate the open limit to ensure door stops. If door does not stop, interchange grey and red wires on open and close limits. Interchange white and grey wires on advanced open and advanced close limits. Remove blue wire from advanced open limit and place it on N.O. pin of advanced close limit.

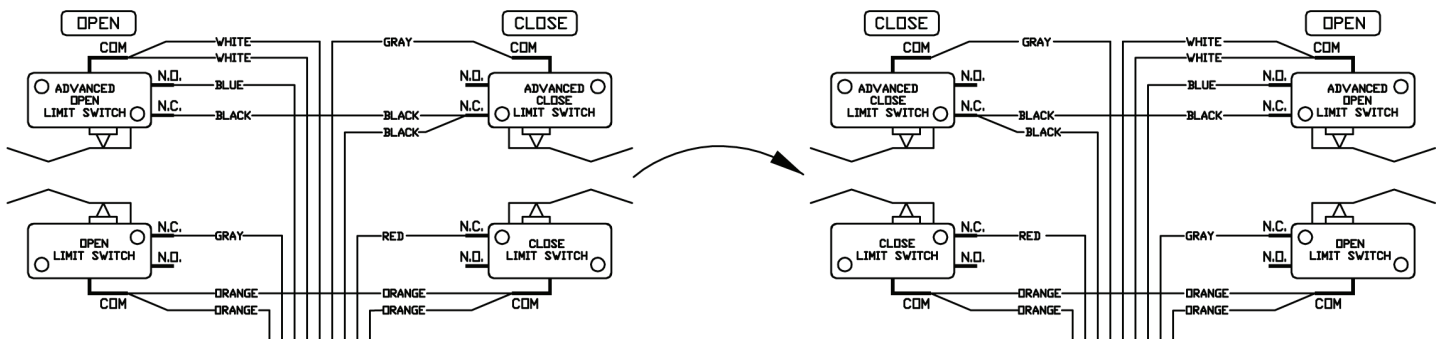

4) Adjust Limit Switch Cams

Using the open/close/stop push button station move door to fully closed and fully open positions and set limit cams to correct position. (See Limit adjustment section C further in this manual for complete detail on the end of travel limit adjustments).

5) Activate Interface Module

After adjusting the open and close limits and verifying the motor rotation, open the door to the full-open position using the open push button (Figure below on left).

At this point the close pushbutton wire must now be moved from terminal T6 to T5. Now connect the black wire (with blue label) to terminal T1 as shown in figure below on right.

NOTE: Ensure the door is in the full open position before connecting the black wire. If door is not in full open position and monitored photo-eyes or safety edge are not connected and operational then door will immediately move in the open direction.

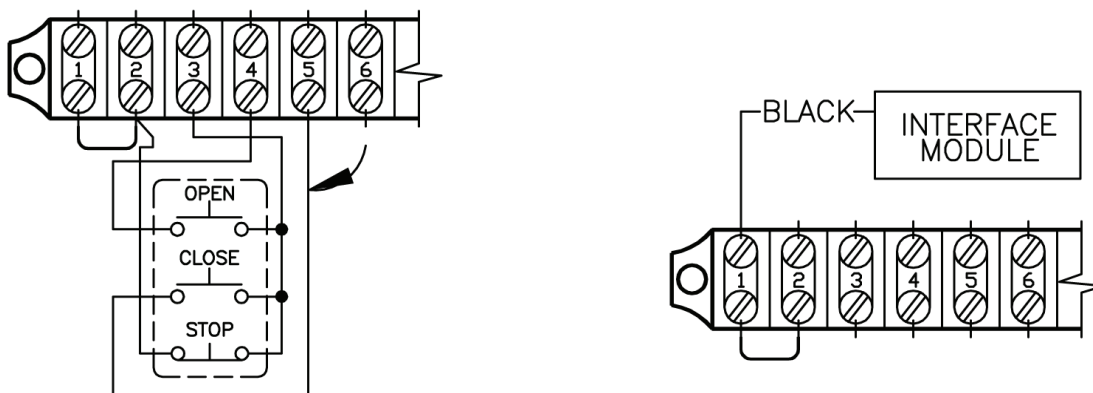

6) Connect Safety Devices

Failsafe Feature: A monitored failsafe safety feature is built into the operator. The operator has provisions to connect one primary monitored safety device as well as one or more non-monitored safety device(s).

Primary monitored safety device: Nice monitored failsafe photo beams or Nice compatible monitored failsafe devices must be connected to terminals P1 and P2 if momentary close on pushbutton is required (B2 mode). If not connected, door can only be closed by constant pressure on close pushbutton. If constant pressure on close pushbutton is removed before door reaches full closed position, then door reverses to full open.

NOTE: Only one monitored failsafe safety device can be connected across terminals P1 and P2.

NOTE: See section E for complete installation instructions for the Nice N-1 or the Fraba photocells.

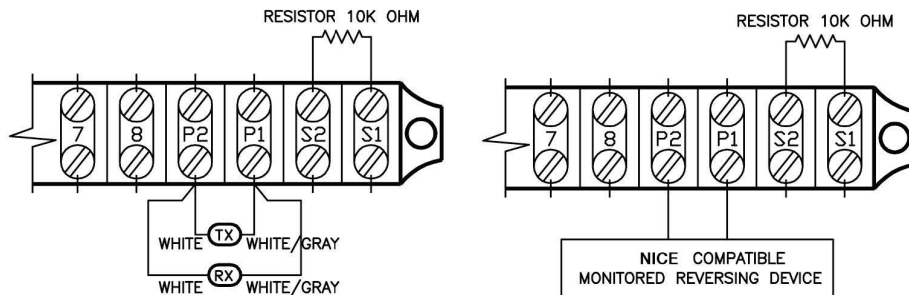

Secondary Non-Monitored Safety Device(s):

A standard 2-wire safety edge, non-monitored reflective or thru-beam photo eye or any other non-monitored reversing devices with a N.O dry contact can be connected to terminals S1 and S2.

NOTE: More than one secondary non-monitored safety device can be connected to terminals S1 and S2.

IMPORTANT: Do not remove resistor that is factory installed across terminals S1 and S2 unless installing a 4-wire electric edge.

4-Wire Electric Edge Connection

A standard 4-wire electric edge can be connected across S1 and S2 terminals as a secondary safety device. Remove the factory installed resistor across terminals S1 and S2, and install resistor across the black and white pair of wires from the electric edge and connect the remaining black and white wire to the S1 and S2 terminals.

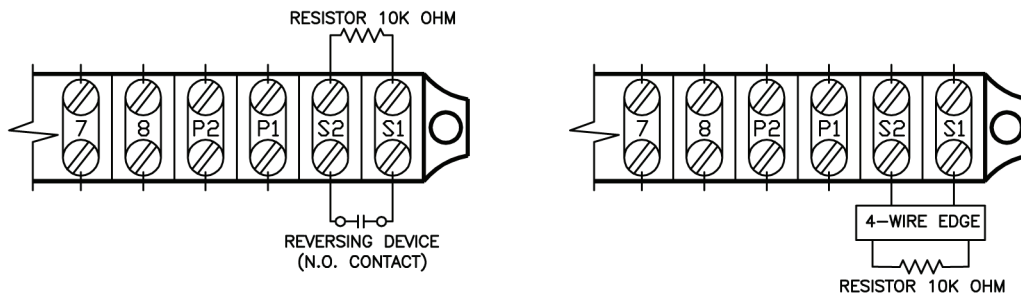

7) Select Mode of Operation

C2 mode of operation (momentary on open, constant pressure on close):

The operator is wired at the factory for momentary on open and constant pressure on close. For single phase limited duty operators, the purple wire is left unconnected. For 3-phase (230V, 460V, 575V 60Hz or 380V 50Hz) operators, white wire is connected to terminal T6.

B2 mode of operation (momentary on open, momentary on close):

If momentary on close is required: For single phase limited duty operators, connect purple wire to terminal #5. For 3-phase (1/2HP 380V 50Hz) operators, remove the white wire from terminal T6 and place it on terminal T3.

The operator functions in B2 mode only when the primary monitored safety device is connected and functioning properly. If it is not connected, operator will go into fault mode and door can only be closed by constant pressure on close and if constant pressure on close is removed before door reaches full close position, door reverses to full open.

SECTION C: PRO-GJ(E) Limited Duty Smart 5.0 logic board

[UL325 (2010) Compliant]

NOTE: The operator is shipped from the factory in the C2 mode (constant pressure close and momentary open). The operator should remain in this mode until all connections and limit switch adjustments are completed.

Power Wiring Instructions

Connect primary power supply directly to the separate power terminal strip supplied using any of the 1-1/8" (2.85 cm) diameter holes provided on control box. Do not connect power supply directly to the circuit board.

Connect single-phase power supply to terminals L/L1 and N/L2 on three-pole power terminal strip (1 10V or 220V 1-phase).

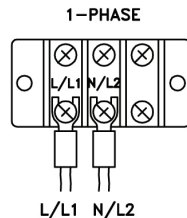

On Board O/C/S PBS Instructions

On-board Open, Close and Stop buttons are provided directly on the board for installation and troubleshooting purposes. In order to operate unit by on-board Open, Close, Stop buttons, the factory installed jumper (#1) between the COM and STOP terminals on the terminal strip must remain connected.

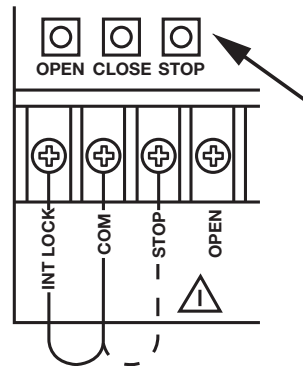

Motor Direction Verification

Make sure the mode of operation is selected to C2.

After electrical power connections are made, manually move door to mid-position. Using the on-board buttons press the "Open" button for several seconds and then press the "Stop" button. If door did not move in correct direction (or if limit cams not moving in correct direction towards the open limit switch) see below:

The operators leave the factory with correct motor and limit shaft direction according to standard door installations. However, for special fire door, through wall mounting or other special door applications, the motor direction and limit switch direction may need to be reversed. To reverse motor rotation, interchange red and yellow wires on the capacitor and interchange the wires on open and close limits. Disconnect the 2 wires from the advanced closed limit switch and re-connect to the auxiliary limit switch provided.

NOTE: Ensure that when the on-board open button is depressed and the door moves in the correct open direction that activation of the open limit switch stops the door.

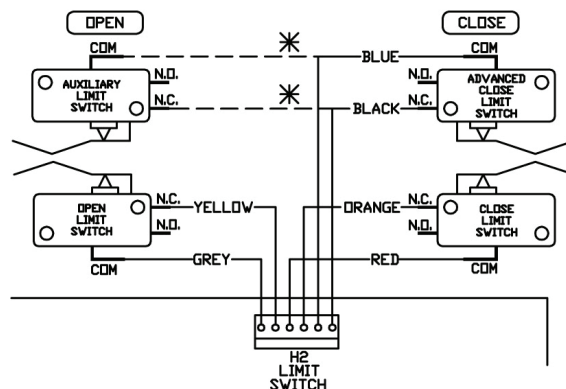

Limit Switch Adjustments

Once the motor rotation and limit cam direction have been verified, adjust the limit cam settings. Please note that when each limit switch is activated the corresponding LED will light up. Refer to operator installation manual for complete limit switch adjustment instructions.

Connection of External O/C/S PBS

Connect O/C/S PBS as shown in diagram.

NOTE: Jumper #1 must be removed after the external O/C/S PBS has been installed.

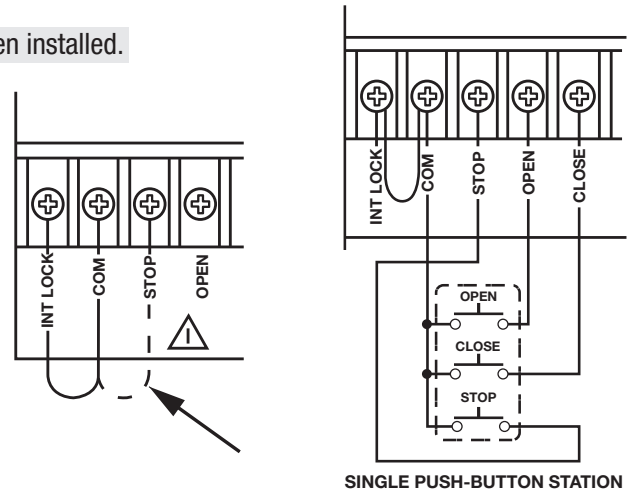

Failsafe Feature

A safety device failsafe feature is built into the logic board. The logic board has provisions to connect one primary monitored safety device as well as 1 or more secondary non-monitored safety device(s).

Primary monitored safety device

Nice monitored failsafe photo beams or Nice compatible monitored failsafe devices must be connected to terminals P1 and P2 as primary monitored safety device. Primary monitored safety device must be connected if momentary activation on close is required in B2, T and TS modes. If it is not connected in B2, T and Ts modes, door can only be closed by constant pressure on close and if constant pressure is removed before door reaches full close position, door reverses to full open.

NOTE: Only one monitored failsafe device can be connected to terminals P1 and P2.

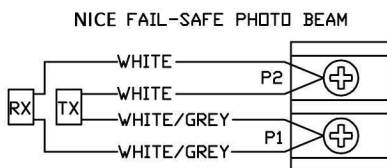

Secondary Non-Monitored Safety Device(s):

A standard 2-wire safety edge, non-monitored photo beams or any other non-monitored reversing devices with a N.O contact can be connected to terminals S1 and S2 as secondary non-monitored safety device.

NOTE: More than one secondary non-monitored safety device can be connected to terminals S1 and S2.

IMPORTANT: Do not remove the resistor that is factory installed across terminals S1 and S2 unless installing a 4-wire electric edge.

4-wire electric edge:

A standard 4-wire electric edge can be connected across S1 and S2 terminals as a secondary safety device.

Remove the factory-installed resistor across terminals S1 and S2 when using a 4-wire electric edge.

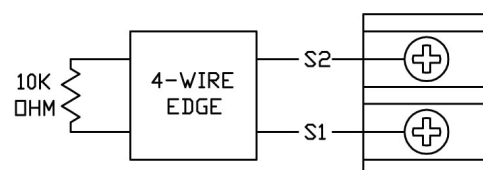
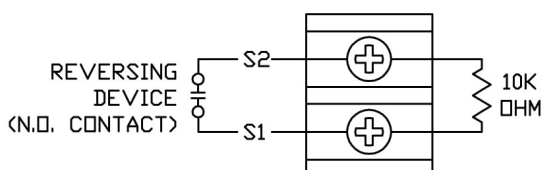

Connection of External Single-Button Device

Connect an external single-button as shown in diagram. Please refer to “Modes of Operation” for the functionality of single-button.

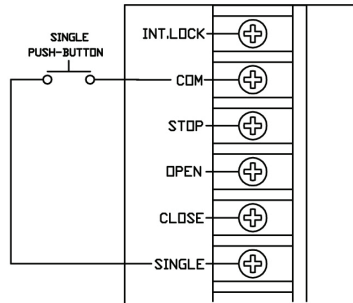

GENERAL INFORMATION: Auxiliary device may be installed to edge terminals, open or close button terminals, and single button terminals providing that they are of the NORMALLY OPEN DRY CONTACT TYPE.

Modes of Operation

All operators leave the factory in the C2 mode setting. Please read all modes of operation and determine which operational mode is desired.

B2 (Momentary on open and close):

- **Open Button:** Momentary activation opens the door. When door is closing, momentary activation reverses the door (OPEN OVERRIDE).
- **Close Button:** Momentary on close.
- **Stop Button:** Momentary activation stops the door.
- **Single button device and external radio control: Open/Close/Reverse.**
- **Safety Devices:** When door is closing, momentary activation reverses the door.
- **Timer to Close:** N/A

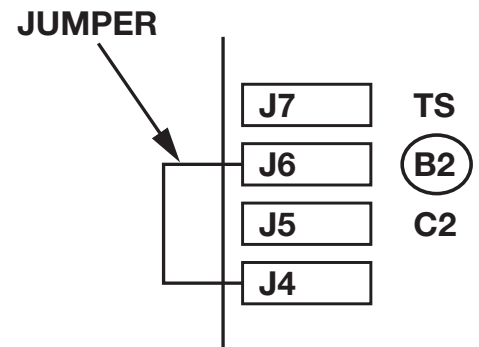

C2 (Momentary open, constant pressure close):

- **Open Button:** Momentary activation opens the door. When door is closing, momentary activation reverses the door (OPEN OVERRIDE).
- **Close Button:** Constant pressure on close. Door will stop when button is released
- **Stop Button:** Momentary activation stops the door.
- **Single Button device:** Open/Stop/Constant pressure on close/stop.
- **External radio receiver:** Momentary activation opens the door (Cannot close the door).
- **Safety Devices:** When door is closing, momentary activation reverses the door.
- **Timer to Close:** N/A

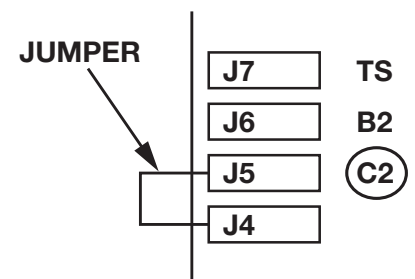

TS: (Momentary on open and close, timer to close secure, STOP BUTTON DISABLES TIMER)

- **Open Button:** Momentary activation opens the door. When door is closing, momentary activation reverses the door. Momentary contact at full-open position re-activates the timer if timer has been disabled previously by stop button.
- **Close Button:** Momentary on close.
- **Stop Button:** If door is opening or closing, momentary activation stops the door. Momentary activation while timer is counting at full open deactivates the timer.
- **Single button and external radio:** Open/Reverse/Refresh timer.
- **Safety Devices:** When door is closing, momentary activation reverses the door. Momentary activation when door is at full open refreshes the timer to close.
- **Timer to Close:** Closes the door from full open. Momentary activation of stop button will deactivate the timer. Timer resumes its normal operation upon momentary activation of open push button or once the close cycle is completed.

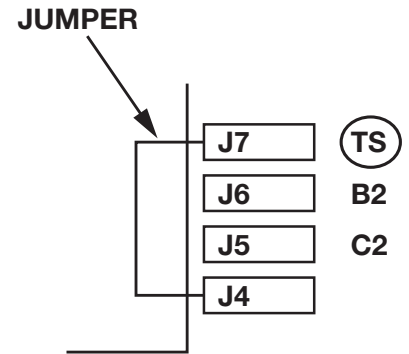

Timer to Close Setup

Timer to close is enabled only in TS mode of operation. There are 3 LED lights on the board to indicate the timer to close value. Default setting of timer to close is 3 seconds. To modify this value, press “TIMER PROGRAM” button until desired value is reached. The LED status changes when the “TIMER PROGRAM” button is pressed each time. The following chart correlates the LED lights status to the timer to close value.

3	2	1	LED
○	○	○	3 Sec.
○	○	●	10 Sec.
○	●	○	30 Sec.
○	●	●	1 Min.
●	○	○	2 Min.
●	○	●	3 Min.
●	●	○	4 Min.
●	●	●	5 Min.
3	2	1	
⊗	⊗	⊗	
SW4		Timer Program	

Status LED

LED	Status	Cause
Fault	ON	<ul style="list-style-type: none"> • Safety devices not connected or functioning properly. • Safety devices are activated.
Power	ON	<ul style="list-style-type: none"> • 24VAC power to logic board is on

SECTION D: For all Operator Control Types

Limit Switch Adjustment

Adjustment of door travel is done by moving the limit cams on the threaded shaft. The position of the 4 limit switches are factory adjusted and should not be altered. The limit switches are:

- **“Open” limit switch:** End of door travel in the fully open position
- **“Closed” limit switch:** End of door travel in the fully closed position
- **“Advanced Open” or “Auxiliary advanced closed” limit switch:** Used for open/close devices or timer to close features.
- **“Advanced Closed” Limit switch:** Used to prevent reversing device from reversing door when door is almost fully closed.

⚠ WARNING ⚠

TO REDUCE THE RISK OF INJURY OR DEATH: DO NOT ATTEMPT TO MAKE LIMIT SWITCH ADJUSTMENTS UNLESS POWER HAS BEEN ELECTRICALLY DISCONNECTED.

To adjust door travel:

1. **Open cycle:** Depress cam plate and spin “Open” limit cam away from “Open” limit switch to increase door travel or spin “Open” limit cam towards the “Open” limit switch to decrease door travel. After each adjustment ensure that cam plate fully engages in slots of both limit nuts.
2. Adjust “Open” limit cam so that door stops at the desired fully open position.
3. **Close cycle:** Depress cam plate and spin “Close” limit cam away from “Close” limit switch to increase door travel or spin “Close” limit cam towards the “Close” limit switch to decrease door travel. After each adjustment ensure that cam plate fully engages in slots of both limit nuts.
4. Adjust “Close” limit cam so that door stops at the desired fully closed position.

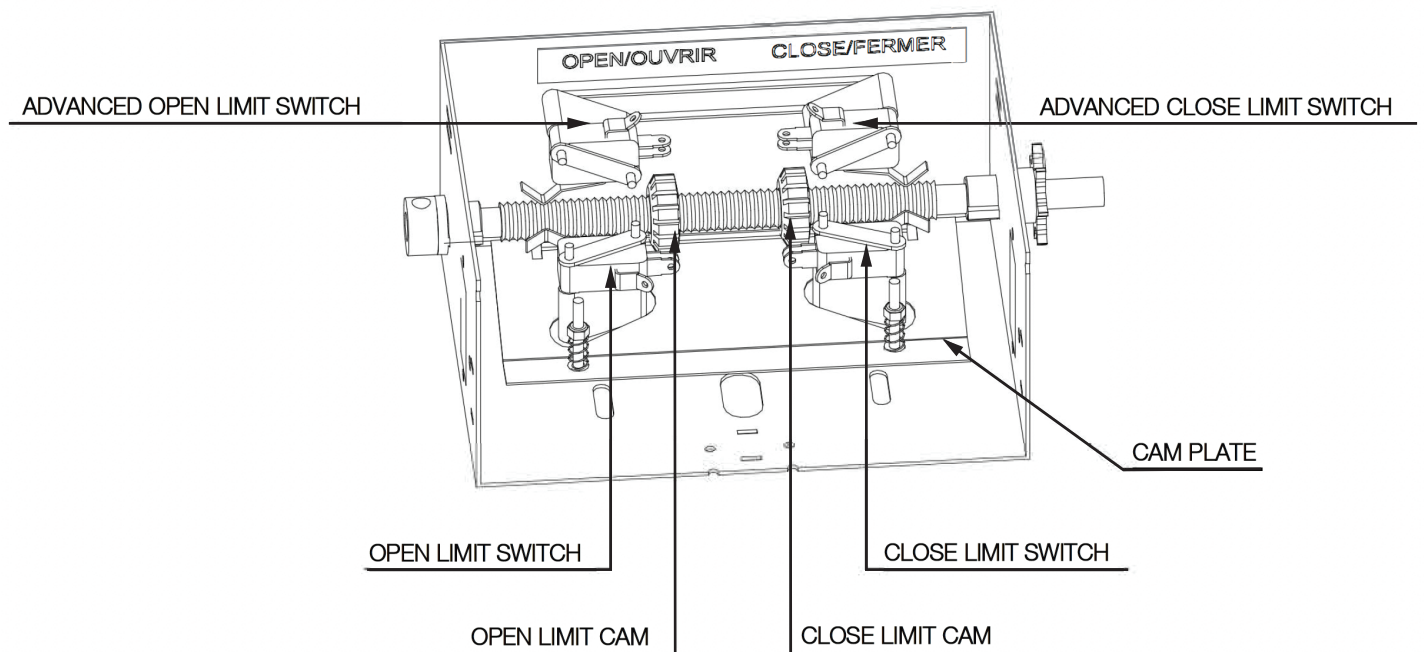

SECTION E: For Operators with Interface Modules or Logic boards

Installation of Nice N-1 or N-4 Photocells

Installation Safety Precautions

⚠ WARNING ⚠

Nice MK00649 NEMA-1 and FRABA MK00697 NEMA 4/4X infrared photo systems are for use only with Nice logic board operators or relay logic operators equipped with the Nice failsafe interface module. Use of this device on other than recommended operators can lead to severe or fatal injury. Follow these instructions carefully.

IMPORTANT

For momentary activation on close, the Nice photobeams (or a Nice 2-wire monitored edge), must be installed as part of the operator system. If a Nice 2-wire monitored edge or the Nice infrared photobeam system is not installed (or not operating correctly), the operator will only operate in fault mode (constant pressure to close).

READ and FOLLOW all installation instructions.

1. Before installing the photo beam, read the door or gate operator's instruction manual fully, so you are aware of all of the unit's functions and features.
2. Wear protective gloves and eye protection when using tools.
3. Before installing photo beam, disconnect all power to door operator to prevent unintended operation and have the door full open or close.
4. Do not reconnect power to the door or gate operator until instructed to do so.
5. Only install photobeams on a properly functioning door or gate operator.
6. Installation and wiring must comply with local building and electrical codes. This device is not intended and must not be installed in an explosive environment.

⚠ WARNING ⚠

Keep fingers and other body parts away from all moving parts of the door and gate operator system while the system is being operated.

⚠ WARNING ⚠

To prevent unintended operation, disconnect power to the door or gate operator prior to installing the photobeam system.

NICE N-1 Photocell (MK00649)

NOTE: The MK00649 photocell system has a maximum range of 24 ft. Sun visor protector optional.

Installation

NOTE: Photo beams should be mounted as close to the door track inside the door to offer maximum entrapment protection.

Wall Installation:

1. Select a location on the wall no more than 6 inches from the floor to install wall mounting brackets on the left and right side of the door. Both brackets must be mounted at the same height for proper alignment.
2. Drill holes in the wall and attach brackets to the wall using screws and nails provided as shown in Figure 1, below.

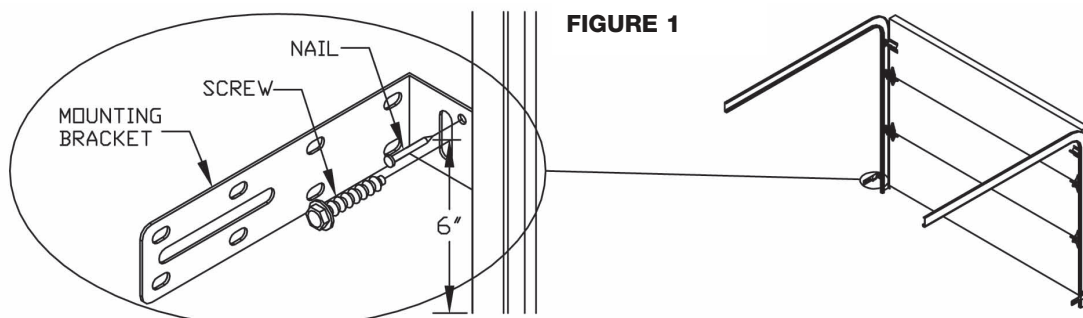

- Using the wing nuts, attach the receiver and transmitter of the photo system to the mounting brackets (with arrow pointing up). Note that the receiver and transmitter can be installed on the left side or right side of the door.
- Adjust the position of the transmitter and receiver on the slot of the brackets. Secure the receiver and transmitter to the mounting brackets as shown in Figure 2.

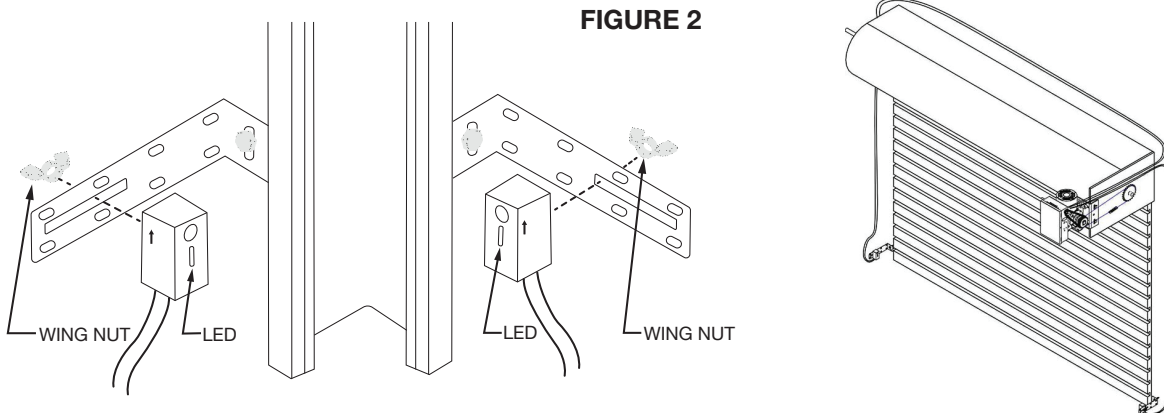

- Pair the two white wires and the two white/gray wires together from transmitter and receiver.
- Connect these paired wires to the P1 and P2 terminals on the logic board (or interface module if applicable) as shown in Figure 3.

FIGURE 3

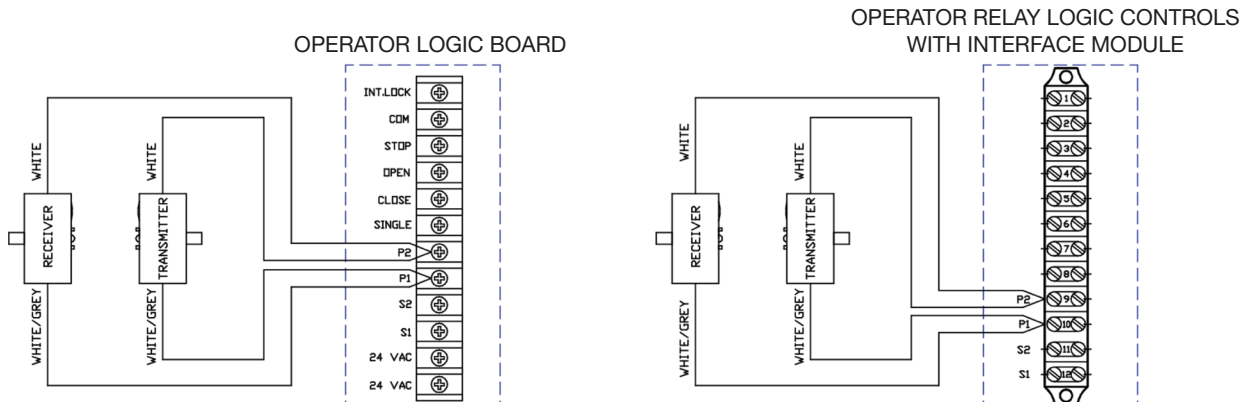

NICE N-4 Photocell (MK00650)

NOTE: The MK00650 photocell system has a maximum range of 24 ft. Sun visor protector optional.

Installation

NOTE: Photo beams should be mounted as close to the door track inside the door to offer maximum entrapment protection.

Wall installation

- Select a location on the wall no more than 6 inches from the floor to install wall mounting brackets on the left and right side of the door. Both brackets must be mounted at the same height for proper alignment.
- Drill holes in the wall and attach brackets to the wall using screws and nails provided as shown in Figure 1, below.

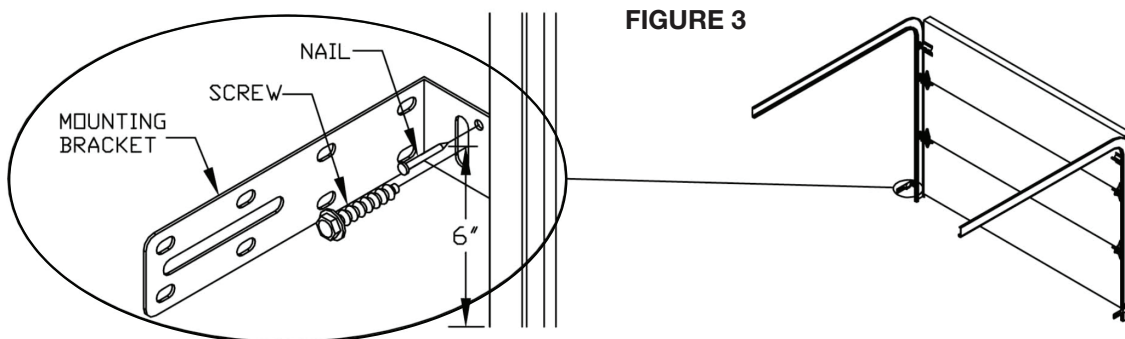

- Using the 8 Phillips head screws, attach the receiver and the transmitter to the two mounting plates (Fig 2A).
- Using the wing nuts, attach the receiver and the transmitter of the photo system to the mounting L-brackets (with arrow pointing up) as shown in Fig 2B. Note that the receiver and transmitter can be installed on the left or right side of the door. For applications requiring the photobeams to be further away from the wall, use the extension brackets provided as shown in Fig 2C.

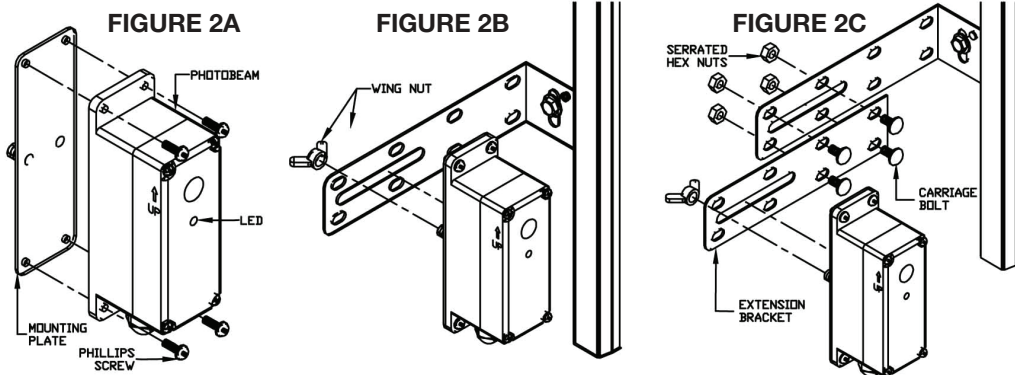

- Adjust the position of the transmitter and receiver on the slot of the brackets and tightly secure the wing nuts.
- Loosen the 4 fastening screws and remove the cover from the photobeam transmitter and receiver housings and insert electrical wire through the strain relief (Fig 3A). Pair the two white/gray wires together from transmitter and receiver.
- Connect these paired wires to the P1 and P2 terminals on the logic board (or interface module if applicable) as shown in Fig 3B. Use minimum 18 gauge wires and secure the wires to wall or ceiling.

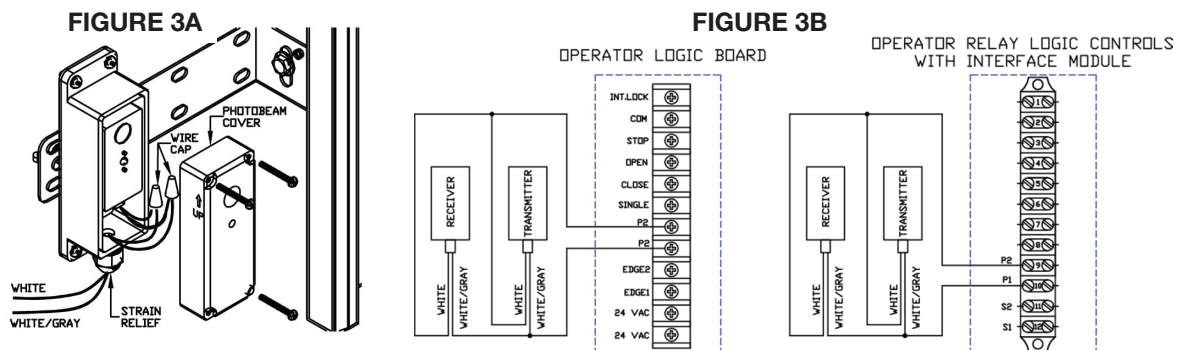

For Nice Nema-1 and Nema-4 photobeams

Aligning the photo beams:

- Turn the power on to the operator. If the transmitter and receiver are installed properly, the lights on both the transmitter (red LED) and receiver (green LED) will be ON.
- If the photo beams are not aligned properly, the receiver light (green) is OFF. Adjust the position of the transmitter and/or the receiver on the slot of the mounting bracket until the light on the receiver is ON and then secure to the bracket.

Photo system operation:

Nice photo beams must be connected for the door to close in momentary mode (unless a Nice monitored 2-wire edge is connected). When the photo system is properly installed and aligned, the infrared beam will detect any obstruction in the path of the beam. Upon detecting an obstruction, closing door will stop and reverse to full open.

The Nice operator control circuit continuously monitors the correct operation of the photo system. If the photo beams are not connected or not functioning properly, the operator will go into fail-safe mode and closing door will reverse to full open. In fail-safe mode door can only be closed by constant pressure on close.

To test the photo system:

- Open the door to full open position.
- Close the door.
- When door is closing, obstruct the beam. The door should stop and reverse.

FRABA N-4/4 Thru-Beam Photocell (MK00697)

NOTE: The MK00697 photocell system has a maximum range of 45 ft. Sun Visor protector optional.

1. Select a location on the wall no more than 6 inches from the floor to install wall mounting brackets on the left and right side of the door. Both brackets must be mounted at the same height for proper alignment.
2. Drill holes in the wall and attach brackets to the wall using screws provided as shown in Figure 4.

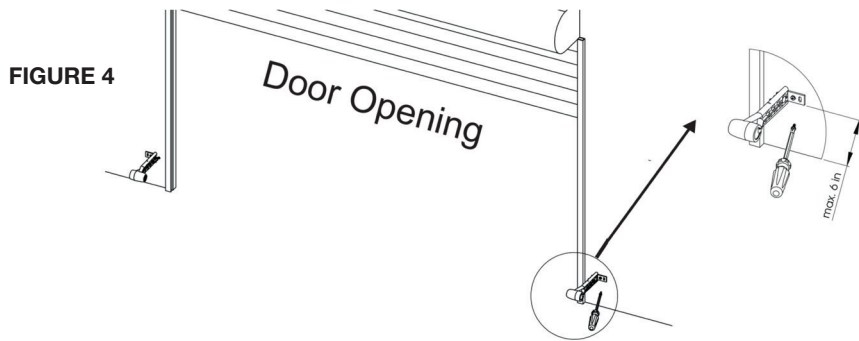

3. Plug sensors into flexible adapters as shown in Figure 5. Please note that the 2 brackets are not identical. The receiver (Rx) must be installed into the receiver adapter and the transmitter (Tx) must be installed into the transmitter adapter (Figure 6).

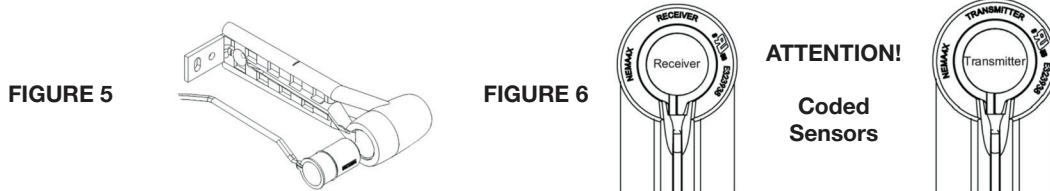

4. Pair the two black and the two black with white tracer wires together from transmitter and receiver. Connect these paired wires to the P1 and P2 terminals on the logic board (or interface module if applicable) as shown in Figure 7. Use minimum 18 gauge wires and secure the wires to wall or ceiling.

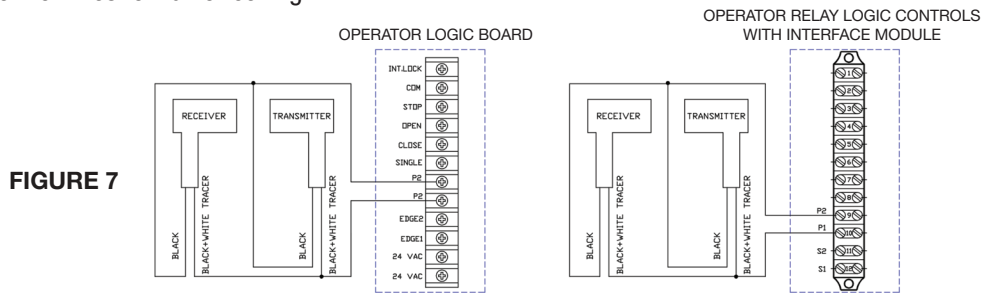

5. Turn the power on to the operator. Align transmitter and receiver by adjusting angle and height of the fixture (Figures 8A and 8B).

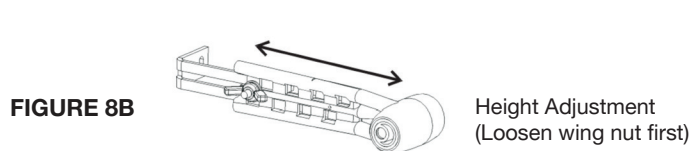
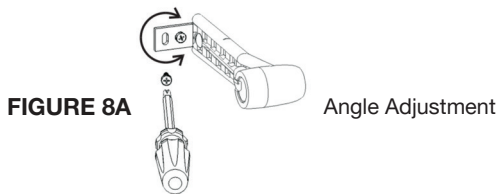

6. Utilize LEDs on photocells for alignment and trouble shooting. Make sure to tighten screws and wing nuts after photocells are aligned.
 - **Red LED (ON), Green LED (ON):** Normal operation
 - **Red LED (ON), Green LED (OFF):** No power. Verify wiring
 - **Red LED (Blinking twice), Green LED (ON):** Bad Alignment, or Obstructed Beam, or Rx defective
 - **Red LED (Blinking twice), Green LED (OFF):** Check power and wiring to Rx, or Rx defective
 - **Red LED (Blinking three times), Green LED (ON):** Rx receiving sunlight (or interference). Install visor or interchange position of transmitter and receiver to reduce sunlight affecting receiver.

To test the photo system: Open the door to full open position. Close the door. When door is closing, obstruct the beam. The door should stop and reverse.

Mechanical External Load Sensing Adjustment

If the operator is equipped with an optional Mechanical External Load Sensing feature (MP00107):

If the grille/gate is obstructed or locked while opening then the load sensing feature will activate and stop grille/gate movement. Upon activation of the load sensing feature, you must initiate a close command to reset the system.

NOTE: SPRING TENSION ADJUSTMENT WING NUT MUST BE ADJUSTED PER INSTALLATION. FACTORY ADJUSTMENT IS STRICTLY FOR OPERATOR TESTING ONLY.

Adjustment Conditions

1. **For larger or heavier grilles/gates:**

If grille/gate experiences a jerking motion during opening direction, or will not initiate open motion at all, then turn wing nut on spring tension adjustment rod clockwise (one turn at a time). This increases spring tension on load sensing feature so as to be less sensitive.

2. **For smaller/lighter grilles/gates:**

If grille/gate will not respond by way of the load sensing feature then it may be necessary to turn wing nut on spring tension adjustment rod counter-clockwise (one turn at a time). This decreases spring tension on load sensing feature so as to be more sensitive.

3. **Chain tension stop bolt:**

This is a pre-set factory setting that limits the movement of the load sensing bracket and **should not be adjusted.**

4. **Limit switch activation bolt:**

This bolt raises or lowers the load sensing limit switch activation point. This assembly is adjusted at factory and **should not need to be adjusted in the field.**

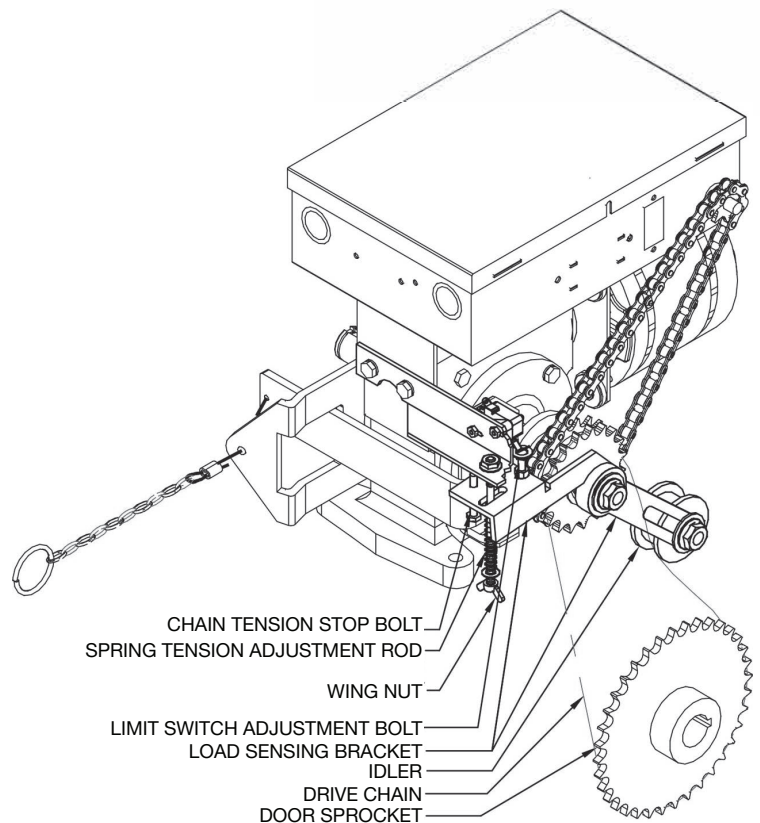
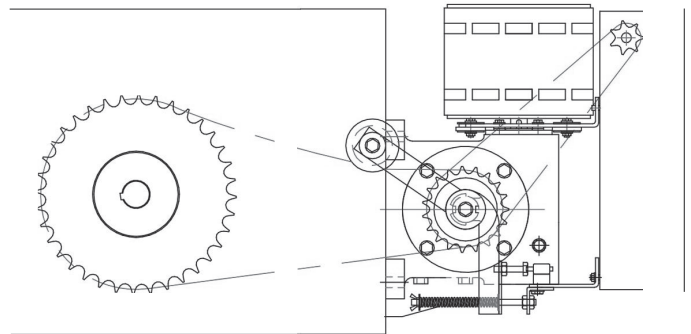

Emergency Manual Operation

- The PRO-GJ operator is equipped with an emergency disconnect device to manually operate door in case of emergency. This feature should not be used to manually operate a malfunctioning door.

⚠ WARNING ⚠

TO REDUCE THE RISK OF INJURY OR DEATH:

DO NOT ATTEMPT TO USE EMERGENCY DISCONNECT SYSTEM WHILE OPERATOR IS RUNNING.

POWER TO THE OPERATOR SHOULD BE TURNED OFF PRIOR TO OPERATING MANUALLY.

1. **If operator is supplied with standard chain keeper:** Pull the disconnect chain through the hole of keyhole and lock in place by inserting chain in slot of keyhole.

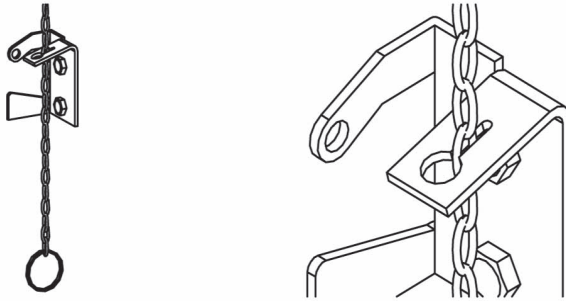

2. **If operator is supplied with optional floor level disconnect lever:** Pull disconnect lever downwards and lock in place by bending lever around bracket lip as shown.



3. Operate door by opening or closing door by hand. To return to electrical operation, release disconnect chain and allow to return to original position.



NOTE: If door is jammed (slide lock was left on when activating the door operator for example), a rotary knob is provided on the input shaft of the reducer. Rotate this knob in appropriate direction to slightly move door to manually free-up the jammed door.

WARNING

TO REDUCE THE RISK OF INJURY OR DEATH:

DO NOT ATTEMPT TO SERVICE THE OPERATOR UNLESS POWER SUPPLY HAS BEEN DISCONNECTED.

- Inspect manual function of the door every 3-months. Make sure that door runs smoothly. If door does not manually open or close freely, have a qualified service person make repairs. Do not attempt to electrically operate a malfunctioning door.
- **Every 3 months:**
 1. Verify that door area is kept clean. Remove any obstructions that would prevent proper door operation.
 2. Check for any excessive slack in chains. If chain adjustment is required verify and adjust limit switches, if necessary.
 3. Lubricate chains, bearings and limit shaft.
 4. Verify that motor and operator runs smoothly and quietly.
- **Every 6 months:**
 1. Verify tightness of all fasteners and set screws.
 2. Verify that operator is properly secured.
 3. Inspect manual disconnect.
- **Every 12 months:**
 1. Perform a complete service check.
 2. Verify that inside of control box is clean and that grounding wires, terminations and power terminations do not show signs of corrosion.
 3. Verify tightness of all terminal strip screws and electrical connections.
 4. Verify power supply, voltage of input terminals during operation.
 5. Verify that current consumption of operator corresponds to nameplate information.

Gearhead Operator Pro-GJ Parts List

CODE	ITEM #	DESCRIPTION (PRO-GJ)	QUANTITY
MB01008	1	MOTOR 1/2HP	1
MC00026	2	GEAR REDUCER LSS 52 45:1	1
MM00142	3A	CONTROL BOX PRO-GJ MSI0155 (For 1-phase operators)	1 *
MM00256	3B	PRO-GJRW CONTROL BOX MSI0250 (For 3-phase operators)	1 *
MM00140	4A	CONTROL BOX COVER PRO-GJ MSI0156 (For 1-phase operators)	1 *
MM00257	4B	PRO-GJRW CONTROL BOX COVER MSI0251 (For 3-phase operators)	1 *
MM00046	5	CONTROL BOX HINGE 2	1
MM00141	6	REAR CONTROL BOX SUPPORT BRACKET PRO-GJ MSI0160	1
MG00015	7	LOCK WASHER 1/4"	2
MF00006	8	HEX HEAD BOLT 1/4-20UNC x 1/2" (Full thread)	2
MF00046	9	H.H. SLOTTED SELF ROUNDING WASHER HEAD SCREW 10-32 UNF x 1/2"	5
MO00002	10	CAM PLATE COMPRESSION SPRING (.178IDx.032GX.55L)	2
MG00007	11	HEX NYLON LOCK NUT 6-32UNC	2
MH00001	12	BRONZE T-BUSHING 3/8" ID	2
MH00006	13	COLLAR 3/8 ID	1
MG00124	14	FLAT WASHER PRO-GJ 3/8" ID x 5/8" OD x 1/16" TH	3
MG00003	16	DOUBLE NUT FOR LIM-SW.	4
MG00016	17	FLAT WASHER# 10	4
MM00024	18	CAM PLATE MSI0013	1
MK00004	19	LIMIT SWITCH (STANDARD)	4
MF00003	20	R.H. PHILLIPS MACHINE SCREW 4-40 UNCx1-1/2	8
ME00048	21	KEYWAY 1/4" SQ. x 3/4" LONG	2
MF00081	22	HEX HEAD BOLT 1/4-20UNC x 4-1/2" (Not full thread)	1
MM00143	23	PIVOT SUPPORT U-PLATE (MSI0158)	1
MG00042	24	LOCK WASHER 5/16"	8
MF00035	25	HEX HEAD BOLT MB x 20mm	6
MM00144	26	PRO-GJ DISCONNECT LEVER (MSI0157)	1
MI00022	27	COUPLING (PRO-GJ) 1	4
MF00104	28	HEX HEAD BOLT MB x 25mm (OPTIONAL)	2
MO00016	29	DISCONNECT COMPRESSION SPRING (1.075" ID x 0.092GA x 1.25" LG)	1
MG00009	30	HEX NYLON LOCK NUT 1/4-20UNC	1
MR00001	31	DISCONNECT CABLE 3/32 x 12" LONG	1
MG00087	32	THRUST WASHER 1" ID	2
MG00085	33	C-CLIP 7/8 ID	2
MD00230	34	DOUBLE /SINGLE SPROCKET 41B19/410A19	1
MD00245	35	#410 LIMIT CHAIN 47LINK + 1 CON LINK	1
MD00231	36	SPROCKET 410B7 x 3/8" BORE 2SS	1
ME00035	37	LIMIT SHAFT LIGHT DUTY 3/8-1/2 x 8-1/2"	1
MG00030	38	LIMIT CAM 1/2-20 UNF	2
MM00145	39	FRONT SUPPORT BRACKET PRO-GJ (MSI0160)	1
MQ00009	40	SET SCREW 1/4"-20	3
MF00084	41	CHAMFER HEAD BOLT M6 x 20mm	4
MF00004	42	R.H. PHILLIPS MACHINE SCREW 6-32 UNC x1	2
MJ00006	43	LIMIT SWITCH DOUBLE OBLONG SPACER (PLASTIC) 3/4" LONG	4
MQ00011	49	3/32" ALUMINUM OVAL SLEEVE	1
MR00008	50	DISCONNECT SASH CHAIN	1
MQ00008	51	SET SCREW 5/16" -18	2
MG00063	52	HEX NUT 10-32UNF	4
ME00055	53	KEYWAY 3/16" x 1-3/4"	2
MG00010	54	RIBBED HEX NUT 10-32 UNF	4
MG00084	55	FLAT WASHER 1/4" ID OVERSIZE 1"OD	8
MG00086	56	RUBBER WASHER 1/4"ID x 1" OD	4
MU00002	57	KEYRING 1-1/4"	1
MM00247	58	GJ CABLE RELEASE (MSI0242) (OPTIONAL)	1
MI00018	59	MOTOR PULLEY 4L 5/8 ID	1

MSLT/GJ-WW 1-Phase Wiring Diagram

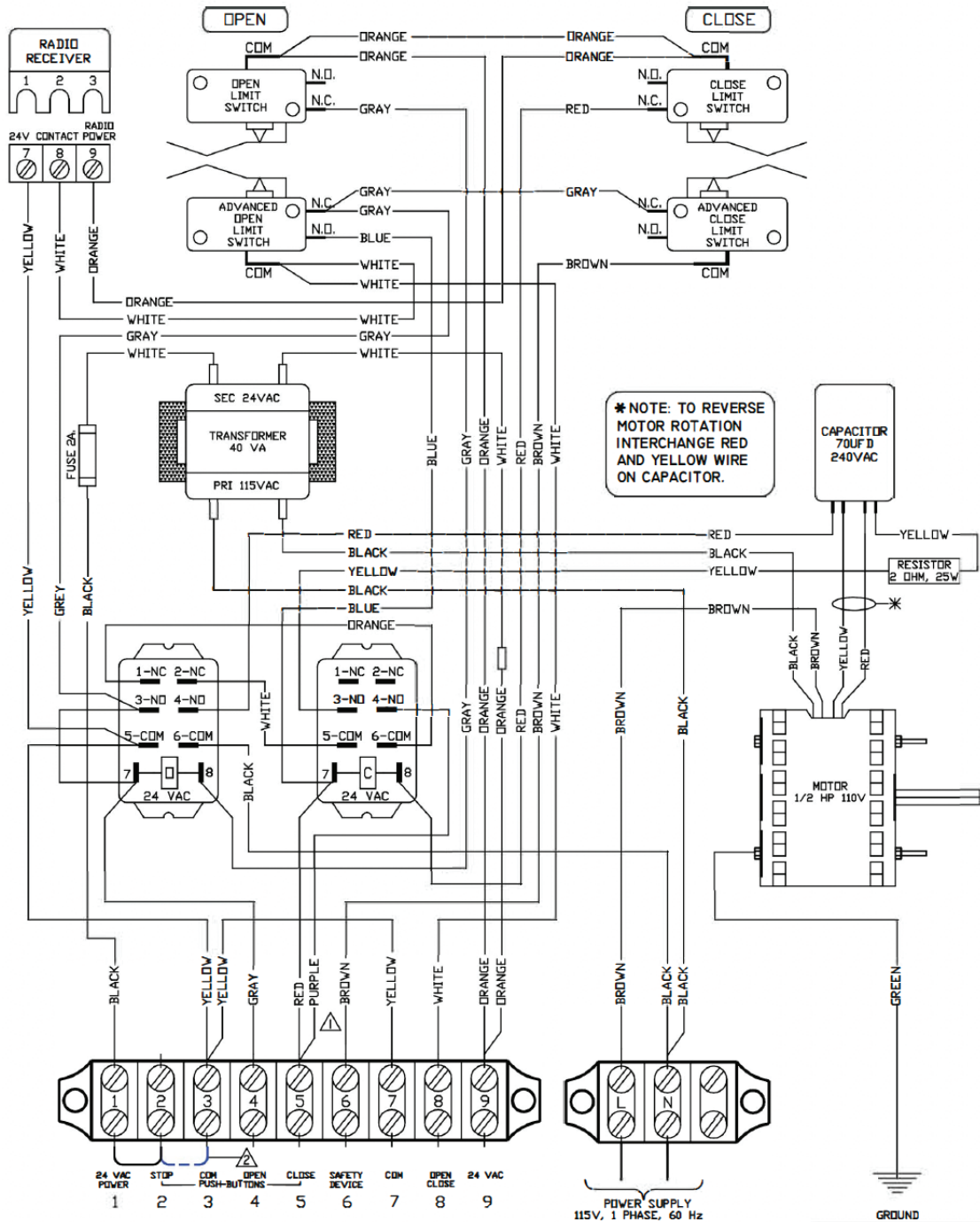

*** NOTE: TO REVERSE MOTOR ROTATION INTERCHANGE RED AND YELLOW WIRE ON CAPACITOR.**

⚠ WARNING
NICE STRONGLY RECOMMENDS THE USE OF ENTRAPMENT PROTECTION SYSTEMS WHEN B2 (MOMENTARY CONTACT) WIRING IS USED.

⚠ CONTROL WIRING OPTION ON CLOSE:
THIS OPERATOR LEAVES THE FACTORY WITH A "C2" WIRING - MEANING THAT CONSTANT PRESSURE IS REQUIRED TO CLOSE THE DOOR. IF MOMENTARY OPERATION ON CLOSE - "B2" WIRING - IS DESIRED, THEN RE-INSTALL THE PURPLE WIRE ON TO TERMINAL #5.

⚠ IF STOP BUTTON NOT USED, ADD JUMPER BETWEEN 2 & 3.

NOTE: MINIMUM 18 AWG WIRE MUST BE USED FOR FIELD CONNECTIONS.

I-PHASE PRO-LT/GJ,1/2HP,110V MSLT/GJ-WW

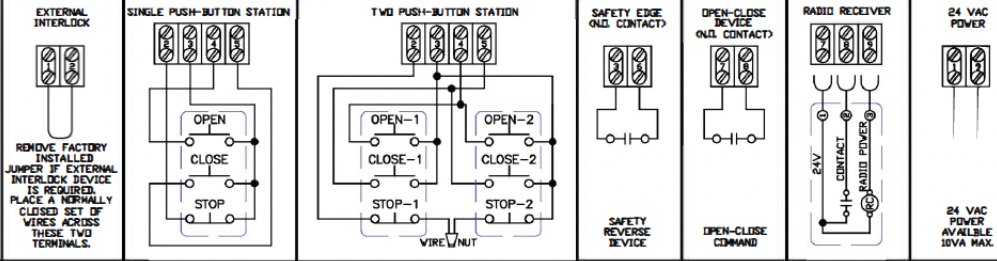

MSLT/GJ2-WW 1-Phase Wiring Diagram

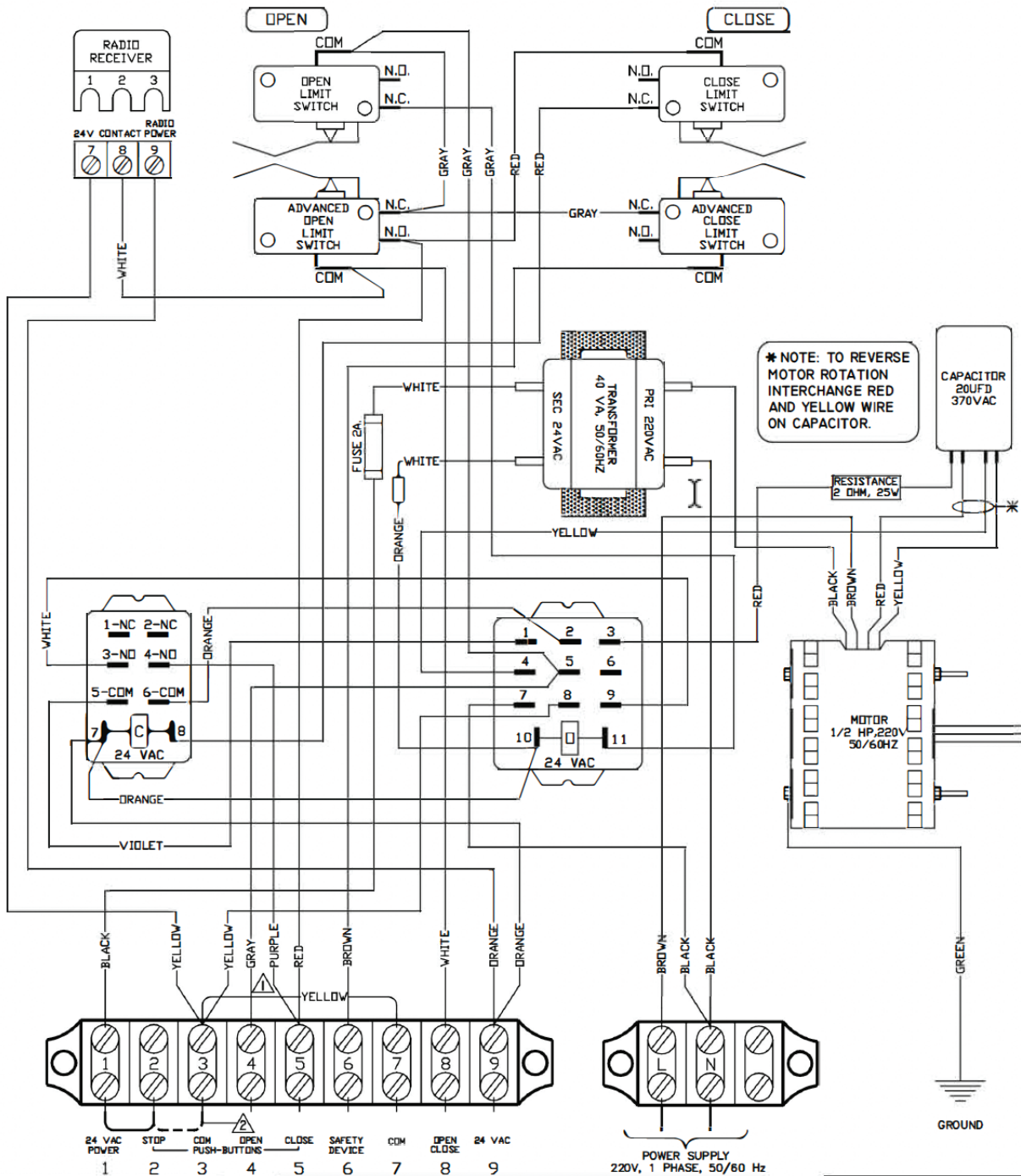

WARNING
NICE STRONGLY RECOMMENDS THE USE OF ENTRAPMENT PROTECTION SYSTEMS WHEN B2 (MOMENTARY CONTACT) WIRING IS USED.

CONTROL WIRING OPTION ON CLOSE:
THIS OPERATOR LEAVES THE FACTORY WITH A "C2" WIRING - MEANING THAT CONSTANT PRESSURE IS REQUIRED TO CLOSE THE DOOR. IF MOMENTARY OPERATION ON CLOSE - "B2" WIRING - IS DESIRED, THEN RE-INSTALL THE PURPLE WIRE ON TO TERMINAL #5.

IF STOP BUTTON NOT USED, ADD JUMPER BETWEEN 2 & 3.

NOTE: MINIMUM 18 AWG WIRE MUST BE USED FOR FIELD CONNECTIONS.

**Pro-LT/GJ, 220V, 50/60HZ, 1-Ø
MSLT/GJ2-WW**

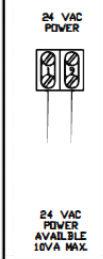
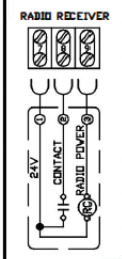
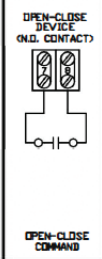
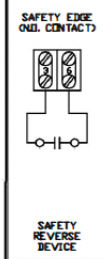
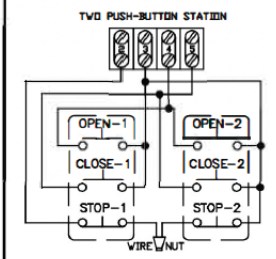
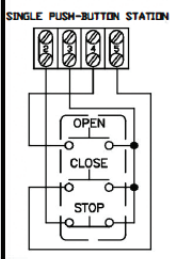
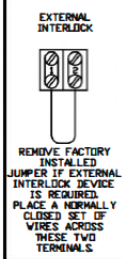

MS300LH-WW 3-Phase Wiring Diagram

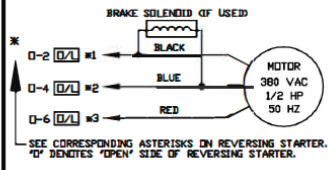
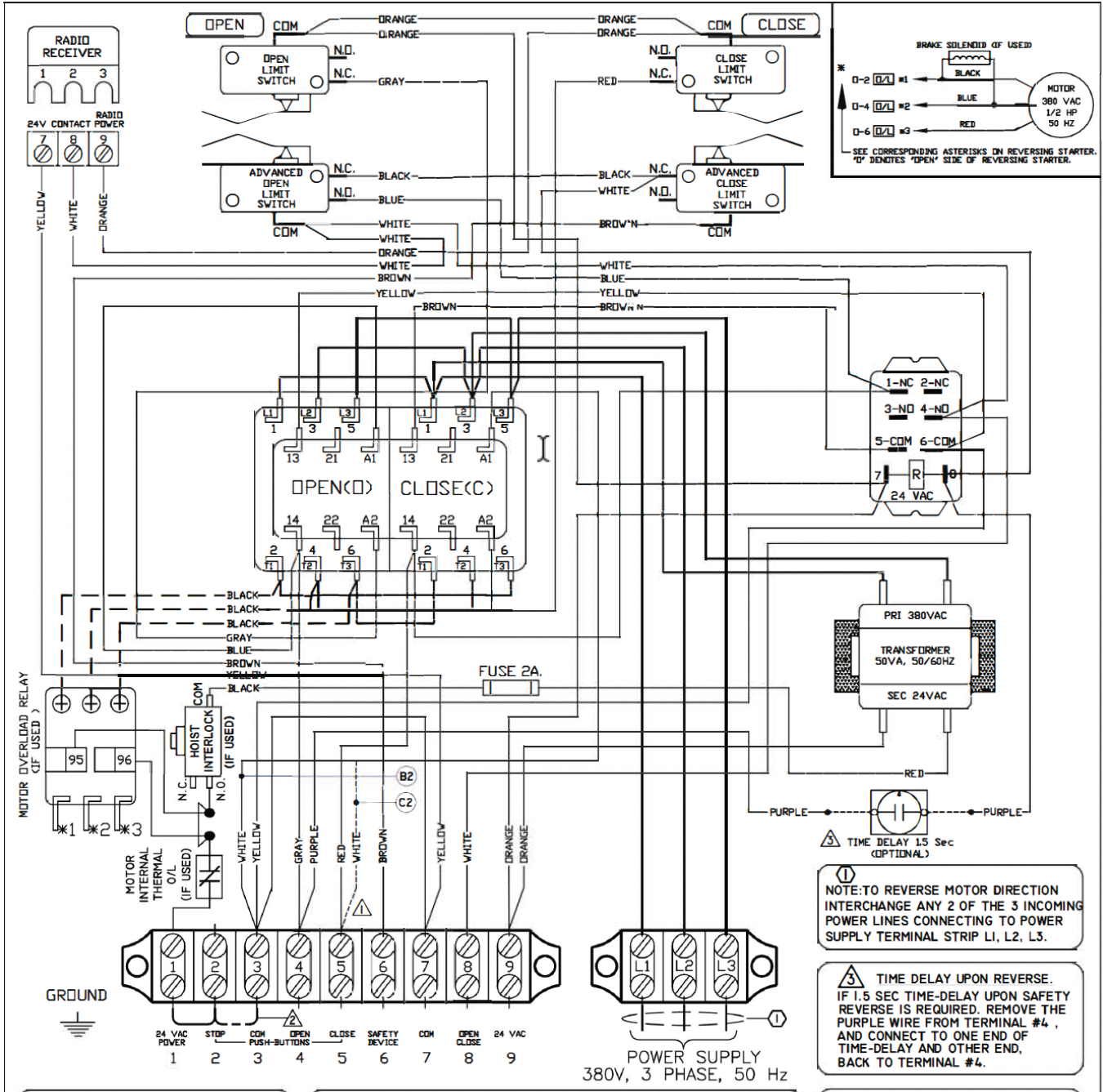

NOTE: TO REVERSE MOTOR DIRECTION INTERCHANGE ANY 2 OF THE 3 INCOMING POWER LINES CONNECTING TO POWER SUPPLY TERMINAL STRIP L1, L2, L3.

TIME DELAY UPON REVERSE. IF 1.5 SEC TIME-DELAY UPON SAFETY REVERSE IS REQUIRED. REMOVE THE PURPLE WIRE FROM TERMINAL #4, AND CONNECT TO ONE END OF TIME-DELAY AND OTHER END, BACK TO TERMINAL #4.

IF STOP BUTTON NOT USED, ADD JUMPER BETWEEN 2 & 3.

NOTE: MINIMUM 18 AWG WIRE MUST BE USED FOR FIELD CONNECTIONS.

WARNING
NICE STRONGLY RECOMMENDS THE USE OF ENTRAPMENT PROTECTION SYSTEMS WHEN B2 (MOMENTARY CONTACT) WIRING IS USED.

CONTROL WIRING OPTION ON CLOSE:
THIS OPERATOR LEAVES THE FACTORY WITH A "C2" WIRING - MEANING THAT CONSTANT PRESSURE IS REQUIRED TO CLOSE THE DOOR. IF MOMENTARY OPERATION ON CLOSE - "B2" WIRING - IS DESIRED, THEN REMOVE THE WHITE WIRE FROM TERMINAL #5 AND PLACE ON TERMINAL #3.

3-PHASE PRO-LJ/LH/LT/LHA/GJ 1/2HP, 380V, 50HZ | REV. E

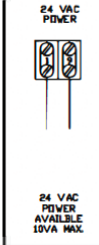
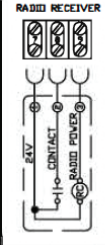
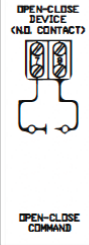
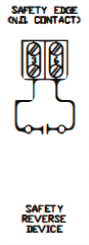
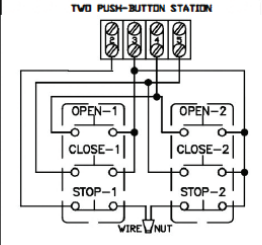
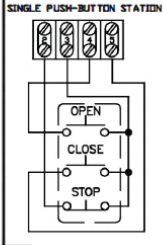

MSLGJ-IM-WW 1-Phase Wiring Diagram

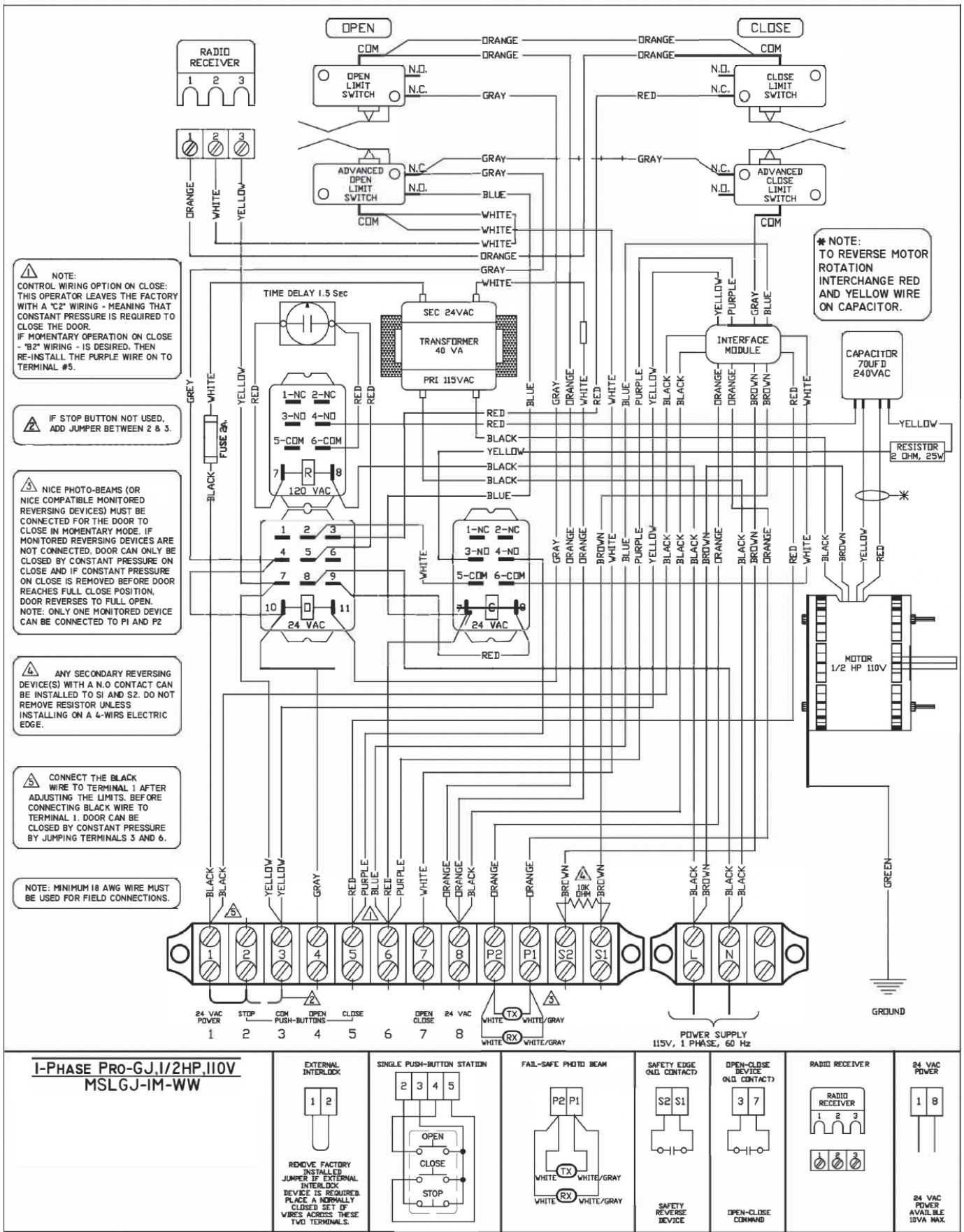

MSGJ2-IM-WW Wiring Diagram

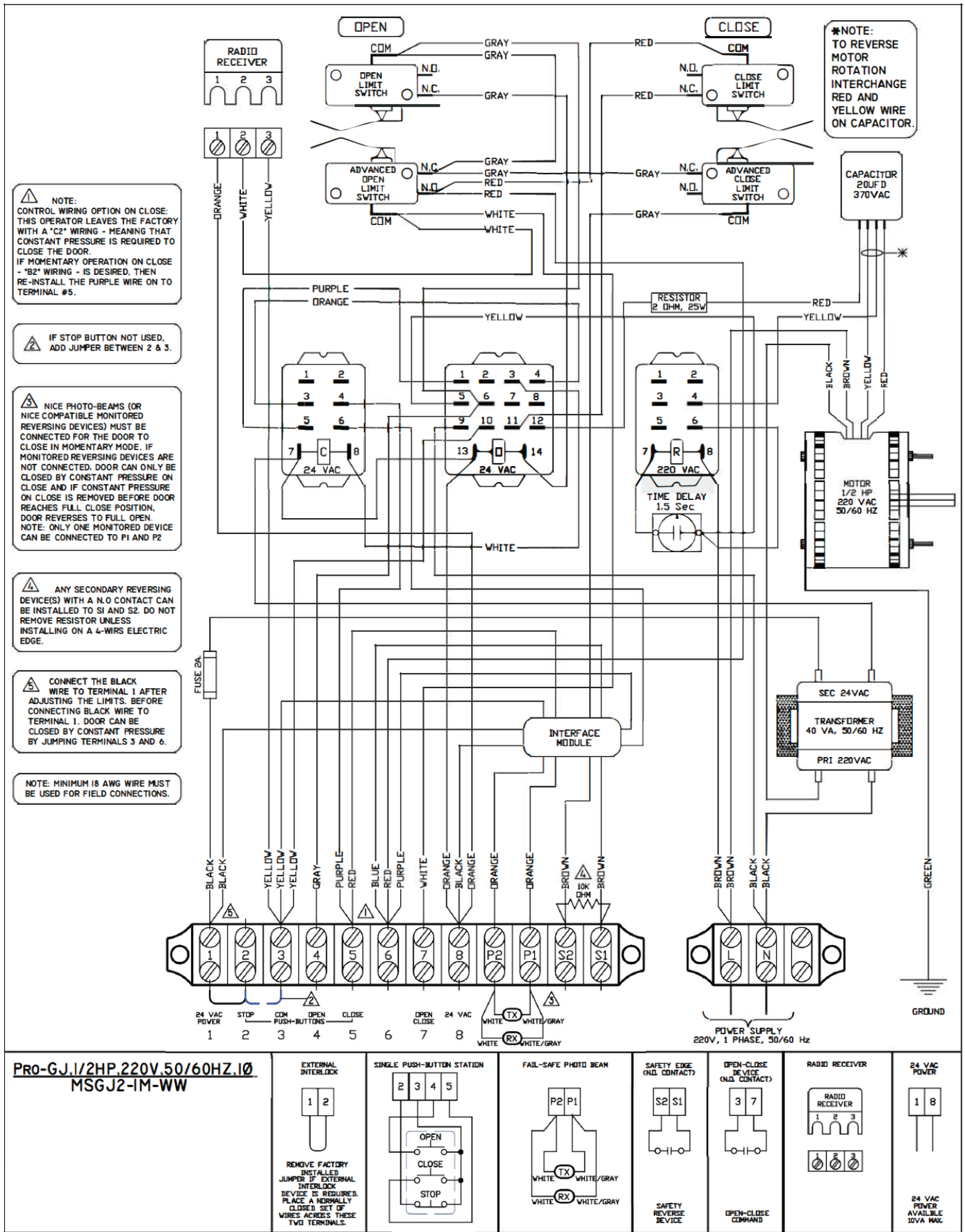

MS300LH-IM-WW 3-Phase Wiring Diagram

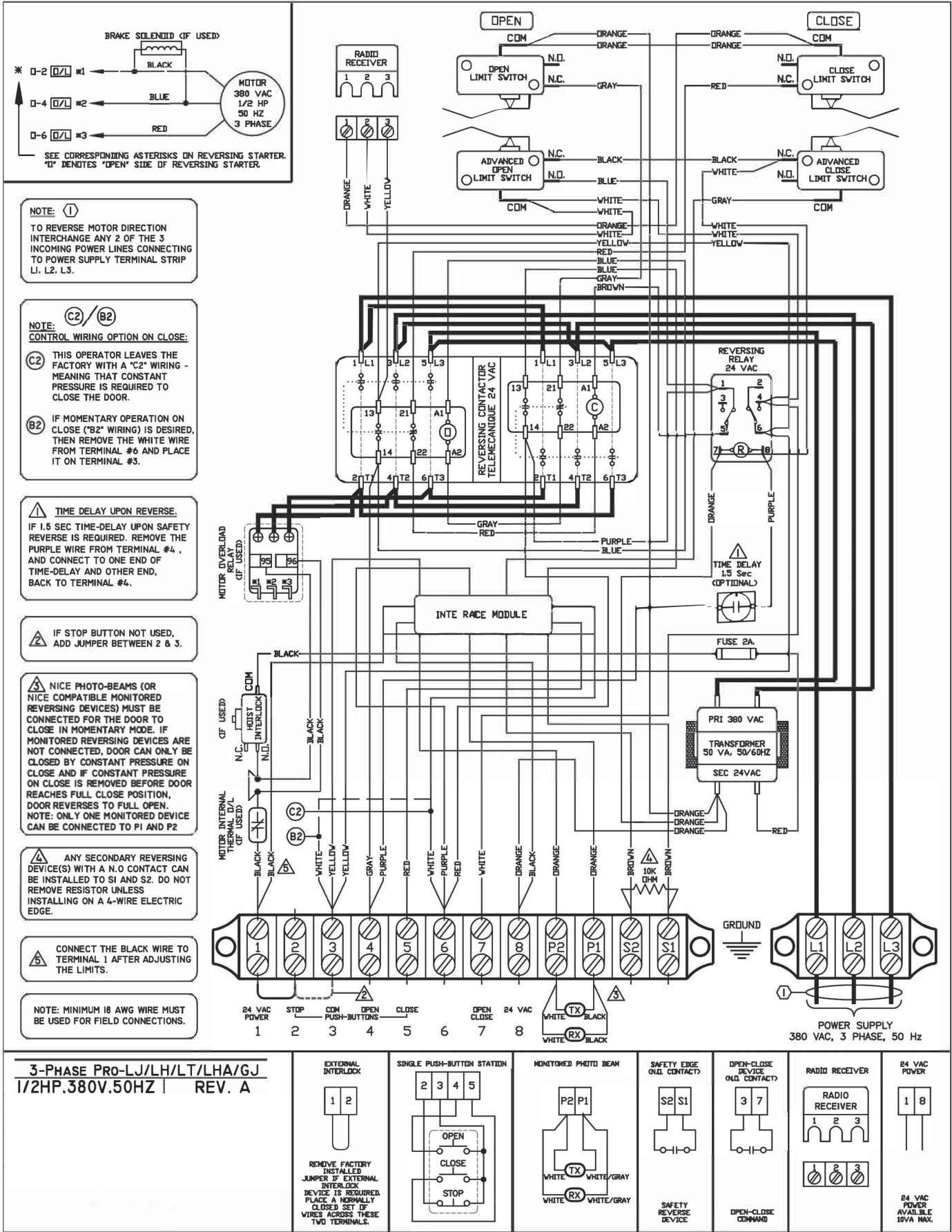

NOTE: (1)
 TO REVERSE MOTOR DIRECTION INTERCHANGE ANY 2 OF THE 3 INCOMING POWER LINES CONNECTING TO POWER SUPPLY TERMINAL STRIP L1, L2, L3.

NOTE: (C2) / (B2)
NOTE: CONTROL WIRING OPTION ON CLOSE:
(C2) THIS OPERATOR LEAVES THE FACTORY WITH A "C2" WIRING - MEANING THAT CONSTANT PRESSURE IS REQUIRED TO CLOSE THE DOOR.
(B2) IF MOMENTARY OPERATION ON CLOSE ("B2" WIRING) IS DESIRED, THEN REMOVE THE WHITE WIRE FROM TERMINAL #6 AND PLACE IT ON TERMINAL #3.

⚠ TIME DELAY UPON REVERSE.
 IF 1.5 SEC TIME-DELAY UPON SAFETY REVERSE IS REQUIRED, REMOVE THE PURPLE WIRE FROM TERMINAL #4, AND CONNECT TO ONE END OF TIME-DELAY AND OTHER END, BACK TO TERMINAL #4.

⚠ IF STOP BUTTON NOT USED, ADD JUMPER BETWEEN 2 & 3.

⚠ NICE PHOTO-BEAMS (OR NICE COMPATIBLE MONITORED REVERSING DEVICES) MUST BE CONNECTED FOR THE DOOR TO CLOSE IN MOMENTARY MODE. IF MONITORED REVERSING DEVICES ARE NOT CONNECTED, DOOR CAN ONLY BE CLOSED BY CONSTANT PRESSURE ON CLOSE AND IF CONSTANT PRESSURE ON CLOSE IS REMOVED BEFORE DOOR REACHES FULL CLOSE POSITION, DOOR REVERSES TO FULL OPEN. NOTE: ONLY ONE MONITORED DEVICE CAN BE CONNECTED TO P1 AND P2.

⚠ ANY SECONDARY REVERSING DEVICE(S) WITH A N.O CONTACT CAN BE INSTALLED TO S1 AND S2. DO NOT REMOVE RESISTOR UNLESS INSTALLING ON A 4-WIRE ELECTRIC EDGE.

⚠ CONNECT THE BLACK WIRE TO TERMINAL 1 AFTER ADJUSTING THE LIMITS.

NOTE: MINIMUM 16 AWG WIRE MUST BE USED FOR FIELD CONNECTIONS.

3-PHASE PRO-LJ/LH/LT/LHA/GJ
1/2HP.380V.50HZ | REV. A

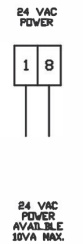
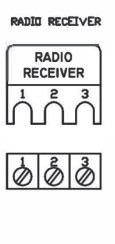
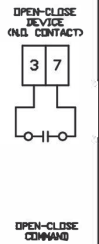
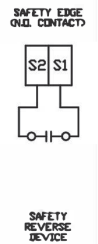
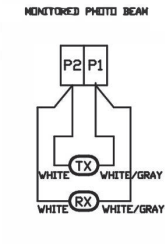
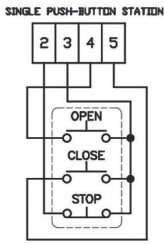
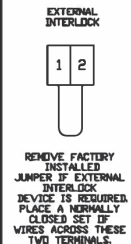

MSLLHRIIOV-WW 1-Phase Wiring Diagram

1 IF STOP BUTTON USED, REMOVE JUMPER BETWEEN "STOP" AND "COM" TERMINALS.

2 NICE MONITORED PHOTO BEAMS OR NICE COMPATIBLE MONITORED SAFETY DEVICES MUST BE CONNECTED TO P1 AND P2 FOR THE DOOR TO CLOSE IN MOMENTARY MODE (B2 OR TS). IF MONITORED SAFETY DEVICES ARE NOT CONNECTED, DOOR CAN ONLY BE CLOSED BY CONSTANT PRESSURE AND IF CONSTANT PRESSURE IS REMOVED BEFORE DOOR REACHES FULL CLOSE POSITION, DOOR REVERSES TO FULL OPEN POSITION. NOTE: ONLY ONE MONITORED DEVICE CAN BE CONNECTED TO P2 AND P1.

3 ONE OR MORE SECONDARY SAFETY DEVICES (WITH A N.O. CONTACT) CAN BE CONNECTED TO S1 AND S2.

4 DOT NOT REMOVE RESISTOR UNLESS INSTALLING ON A 4-WIRE ELECTRIC EDGE.

5 REFER TO INSTALLATION MANUAL FOR APPROPRIATE SURGE PROTECTOR RATINGS.

6 OPERATOR IS SHIPPED FROM FACTORY IN CONSTANT PRESSURE TO CLOSE (C2) MODE OF OPERATION. IF MOMENTARY ON CLOSE IS REQUIRED, REMOVE THE JUMPER FROM PIN "C2" AND PLACE IT ON PIN "B2". IF TIMER TO CLOSE IS REQUIRED, PLACE THE JUMPER ON PIN "TS".

7 TIMER TO CLOSE ADJUSTMENT: DEFAULT SETTING OF TIMER TO CLOSE IS 3 SEC. TO MODIFY THIS VALUE, PRESS "TIMER PROGRAM" BUTTON UNTIL DESIRED VALUE IS REACHED. REFER TO ON BOARD LED INDEX FOR TIMER VALUE INDICATION.

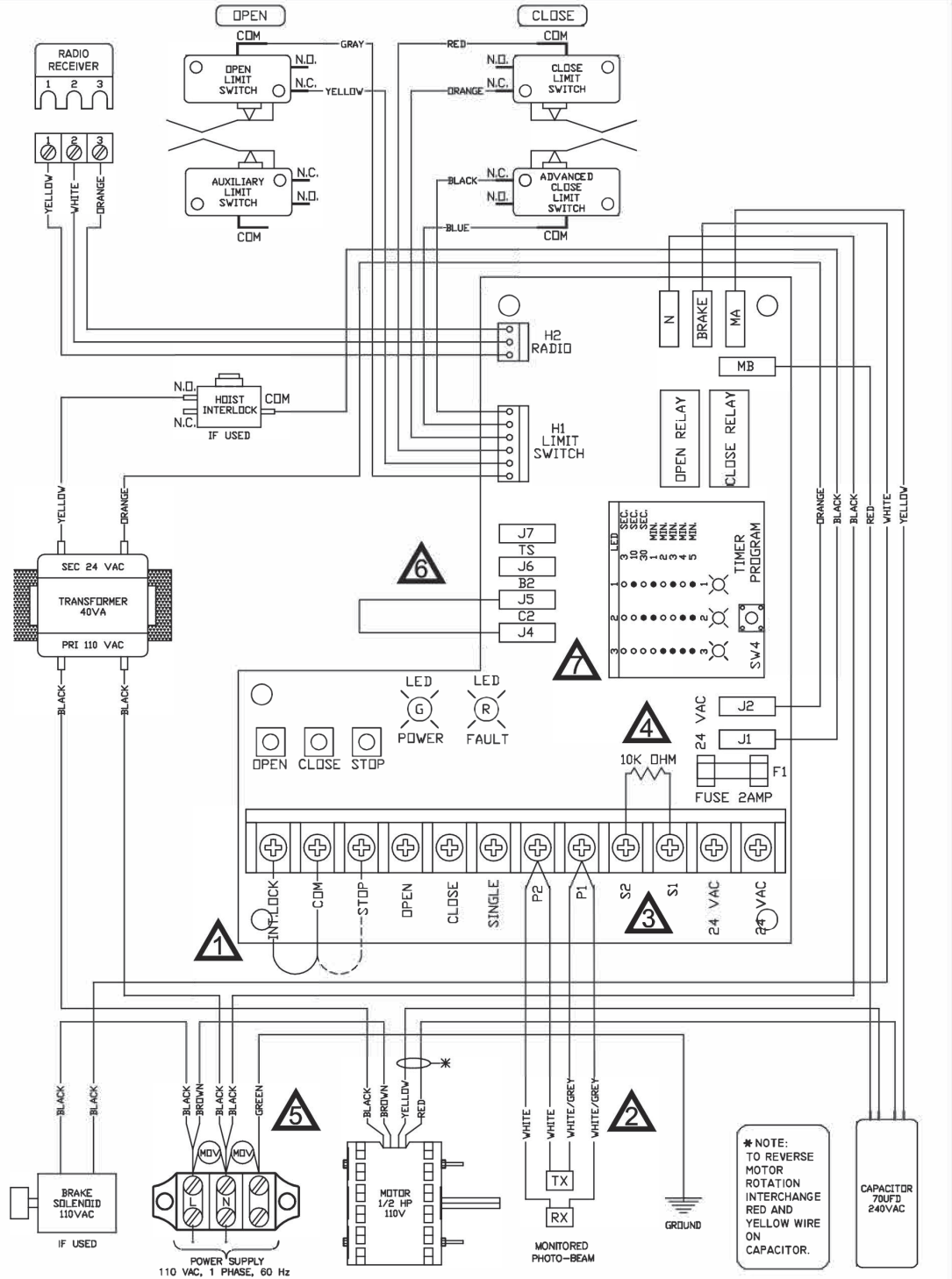

* NOTE: TO REVERSE MOTOR ROTATION INTERCHANGE RED AND YELLOW WIRE ON CAPACITOR.

1-PHASE 110 VAC MSLLHRIIOV-WW

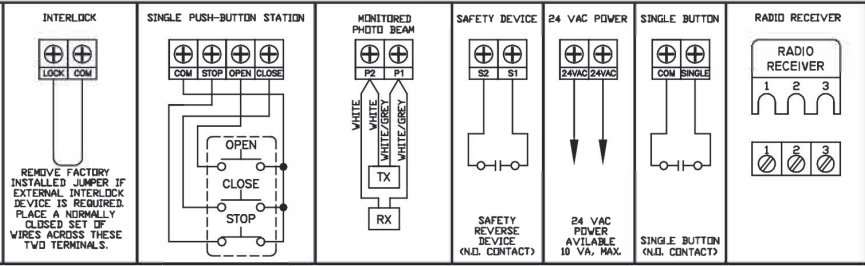

MSLLHR220V-WW 1-Phase Wiring Diagram

1 IF STOP BUTTON USED, REMOVE JUMPER BETWEEN "STOP" AND "COM" TERMINALS.

2 NICE MONITORED PHOTO BEAMS OR NICE COMPATIBLE MONITORED SAFETY DEVICES MUST BE CONNECTED TO P1 AND P2 FOR THE DOOR TO CLOSE IN MOMENTARY MODE (B2 OR TS). IF MONITORED SAFETY DEVICES ARE NOT CONNECTED, DOOR CAN ONLY BE CLOSED BY CONSTANT PRESSURE AND IF CONSTANT PRESSURE IS REMOVED BEFORE DOOR REACHES FULL CLOSE POSITION, DOOR REVERSES TO FULL OPEN POSITION. NOTE: ONLY ONE MONITORED DEVICE CAN BE CONNECTED TO P2 AND P1.

3 ONE OR MORE SECONDARY SAFETY DEVICES (WITH A N.O. CONTACT) CAN BE CONNECTED TO S1 AND S2.

4 DOT NOT REMOVE RESISTOR UNLESS INSTALLING ON A 4-WIRE ELECTRIC EDGE.

5 REFER TO INSTALLATION MANUAL FOR APPROPRIATE SURGE PROTECTOR RATINGS.

6 OPERATOR IS SHIPPED FROM FACTORY IN CONSTANT PRESSURE TO CLOSE (C2) MODE OF OPERATION. IF MOMENTARY ON CLOSE IS REQUIRED, REMOVE THE JUMPER FROM PIN "C2" AND PLACE IT ON PIN "B2". IF TIMER TO CLOSE IS REQUIRED, PLACE THE JUMPER ON PIN "TS".

7 TIMER TO CLOSE ADJUSTMENT: DEFAULT SETTING OF TIMER TO CLOSE IS 3 SEC. TO MODIFY THIS VALUE, PRESS "TIMER PROGRAM" BUTTON UNTIL DESIRED VALUE IS REACHED. REFER TO ON BOARD LED INDEX FOR TIMER VALUE INDICATION

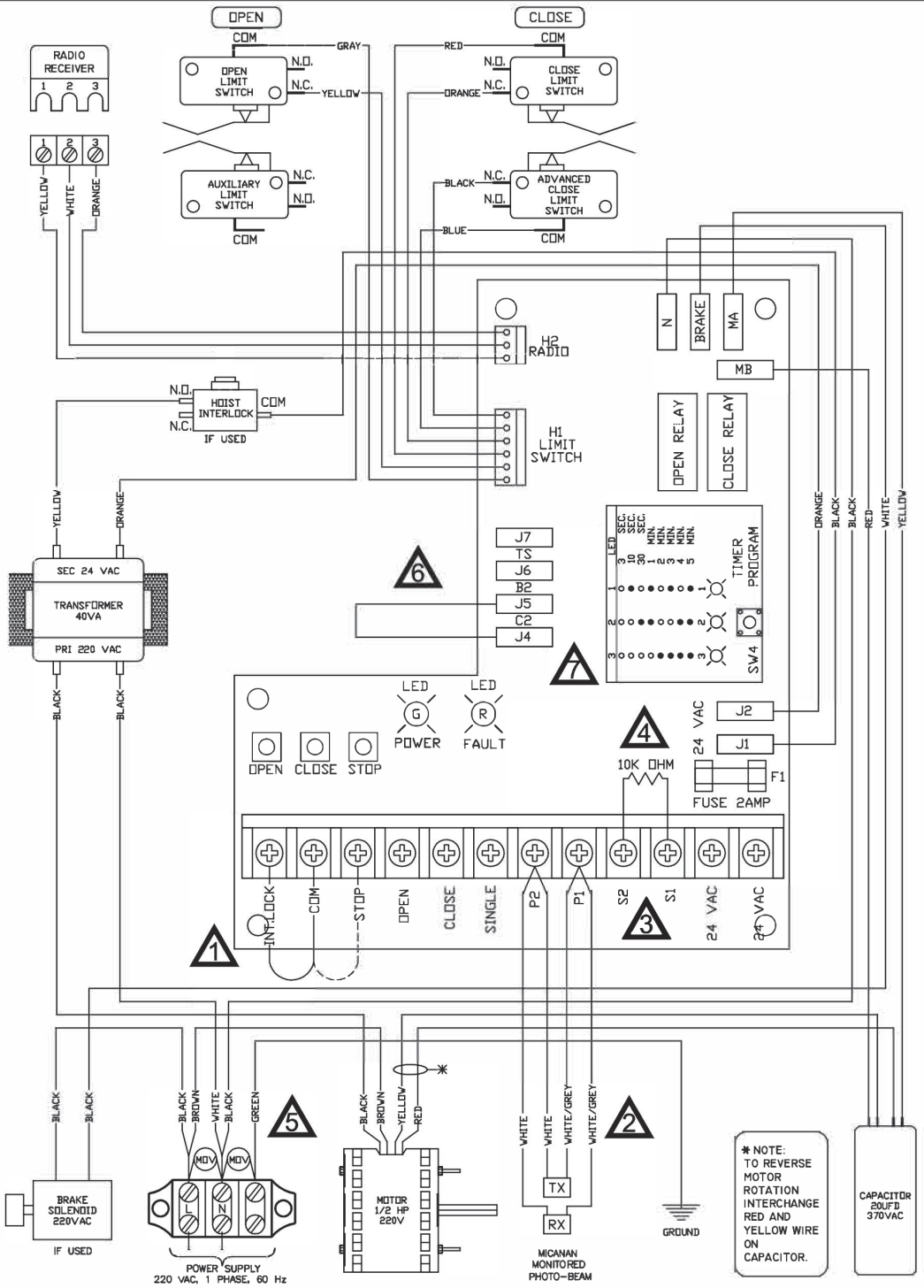

* NOTE: TO REVERSE MOTOR ROTATION INTERCHANGE RED AND YELLOW WIRE ON CAPACITOR.

1-PHASE 220 VAC MSLLHR220V-WW

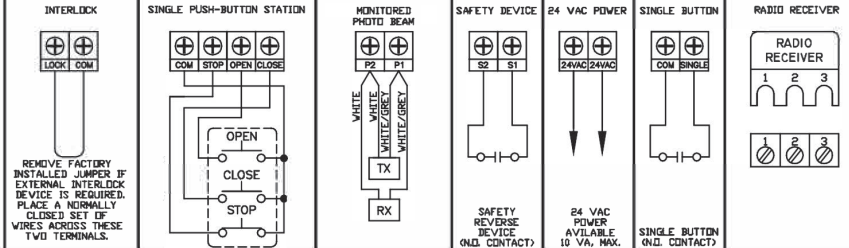

Technical Support:
877-888-1116

Technical Support Hours:
M – F, 8:00 a.m. – 6:00 p.m. ET

Nice North America
c/o Customer Service
5919 Sea Otter Place, Suite 100
Carlsbad, CA 92010



Niceforyou.com

©2024 Nice North America LLC.
All rights reserved.