

Pro-APTC

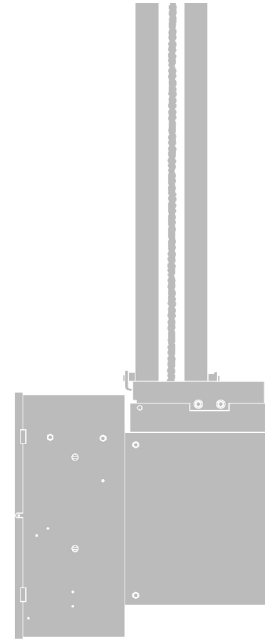

Automation for high cycle sectional overhead doors

Instructions and warnings for installation and use

Nice

Contents

Warranty	3
Verification of Operator and Hardware	4
PRO-APTC Specifications	5
Important Safety Instructions	6
Important Installation Instructions	6
Installation Instructions	7
Wall Mounting Bracket and Operator Installation	8
Wall Mounting Bracket and Operator Installation	9
Electrical Connections	11
SECTION A: PRO-APTC(E)	12
Connection of Power Supply and Control Station	12
Connection of External Single-Button Device	14
Modes of Operation	14
Programming Instructions	16
Run-Timer Setup	16
Mid-Stop Setup	17
Timer to Close Setup	17
Delay on Close Setup (only for use with optional apartment board)	17
On-Board Receiver Programming	17
Installing the Antenna	17
Connection of 110V Red and Green Traffic Lights	18
Programming the On-Board Radio Receiver	19
Operation	19
To Erase all Learned Transmitters	19
Replacing Remote Control Batteries	19
Dip-Switch Setup	20
Status LED	20
SECTION B: For all Operator Control Types	21
Limit Switch Adjustment	21
SECTION C: For Operators with Interface Modules or Logic Boards	22
Installation of Photocells	22
Wall or Floor Mount Installations	22
Photo System Operation	23
FRABA N-4/4 Thru-Beam Photocell (MK00697)	24
Emergency Manual Operation	25
Operator Maintenance	26
Pro-APTC Operator Diagram	27
Pro-APTC Operator Parts List	28
MSL100-110V-3WM-WW 1-Phase Wiring Diagram	30
MSL300APT-WW 3-Phase Wiring Diagram	31
MSLC300APT-WW 3-Phase Wiring Diagram	32
Notes	33

Warranty

Nice North America warrants that materials and workmanship are free from defects for a period of four (4) years or 100,000 cycles, whichever comes first. The start of the warranty will be determined by the date of invoice. Materials returned to Nice deemed defective after examination will be returned at the option of Nice with repaired, new, or re-manufactured parts.

Nice North America will not be responsible for any charges incurred in the process of returning defective material. All returned material must be received pre-paid, or it will not be accepted.

This warranty is limited, and in lieu of all other warranties expressed or implied. There is no expressed liability due on the part of the seller.

MP00046	#40 Drive Chain
MP00023	Double V-belt reduction
MP00045	Cast-iron Pillow block bearings on drive
MP00039	High Cycle modification
PRO-TW/TBW/APTW	Waterproof Modification
PRO-T4X/TB4X/APT4X	Corrosion Proof Modification
PRO-TX/TBX/APTX	Explosion Proof Modification
MP00007*	115 Volt Control Circuit
MP00061**	1.5 Sec Time Delay on Reverse
MP00001**	Timer to Close
PRO-PL	Separate Control Panel
MP00024	Trolley hoist Disconnect
MP00030,78-80	Dual Trolley Assembly
MP00035	Minimum Depth modification

* Not available for logic board controls

** Standard feature with logic board controls

WARNING

DO NOT CONNECT TO ELECTRICAL POWER DURING
INSTALLATION OR SERVICING OF OPERATOR.

IMPORTANT

FOR ANY QUESTIONS CONCERNING THE SAFETY OR OPERATION OF THIS OPERATOR
PLEASE CONTACT NICE AT 1-877-888-1116. SAVE THESE INSTRUCTIONS

Verification of Operator and Hardware

Upon delivery of your Nice heavy-duty trolley door operator, please inspect the unit carefully for damage. Verify that operator horsepower, voltage, phase and amperage correspond to available power supply and door application. Check that along with your operator you have received the following standard hardware.

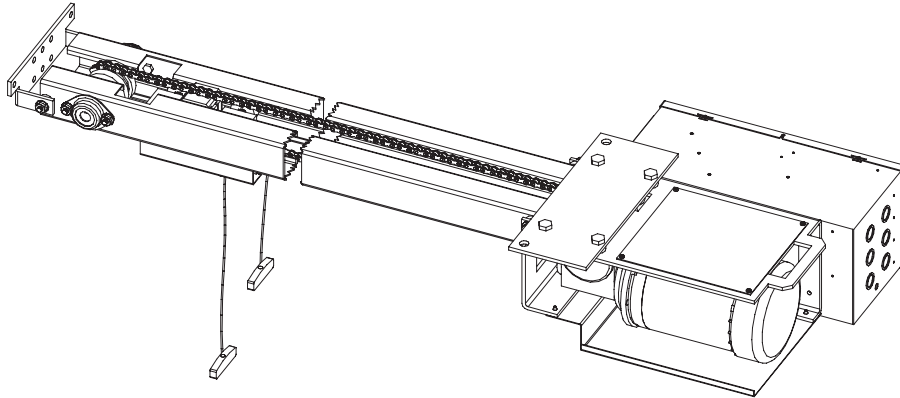

1 x OPEN /CLOSE/STOP 3-button control station

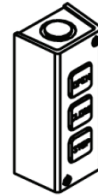

1 x Trolley arm curved bar with wall door attachment bracket

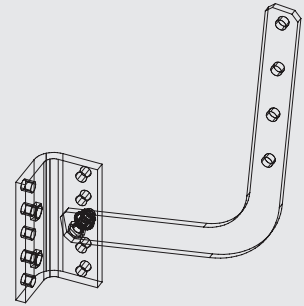

1 x Warning sign



1 set of REBEL monitored photocells (supplied when operator ordered with monitored logic board controls)

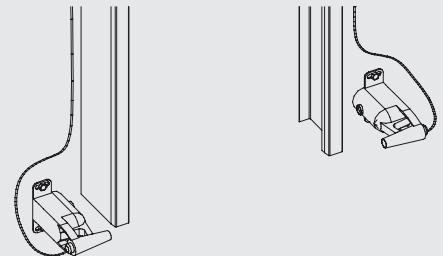

PRO-APTC Specifications

PRO-APTC heavy-duty apartment/condo trolley operators are designed for standard lift overhead sectional garage doors. Model PRO-APTCB is essentially the same as model PRO-APTC with the exception that the PRO-APTCB operator has an electric braking system.

Standard Operator Weight	Operator/rail assembly: 150 Lbs		
Motor			
• Standard	1/2 HP 110V: Instant reversing 1625RPM with built-in manual reset overload protection		
• Continuous duty	1725 RPM industrial type motor		
• Built-in overload protection	(3-phase) or separate full overload protection (1-phase)		
• Voltage	230V 1-phase (60Hz)	230V 3-phase (60 Hz)	220V 1-phase (50Hz)
	460V 3-phase (60Hz)	380V 3-phase (50Hz)	
	575V 3-phase (60Hz)		
• For high speed VFD option:	3/4HP 230V 3-phase Continuous duty 1725 RPM industrial type motor.		
Reduction	Heavy duty worm gear reducer 40:1 reduction, or 25:1 (high speed VFD option)		
Output Shaft Speed	40 RPM		
Door Speed (Standard)	7"/second		
Brake (Model PRO-APTCB)	Magnetic braking system to prevent coasting and maintain door position.		
Wiring Type (3 Options)	Option 1: Full Feature logic board Smart 10.0 (UL325 (2010) compliant). NOTE: Nice compatible primary entrapment device must be connected for B2, T or TS (momentary or timer activation on close) feature. Auxiliary traffic light board.		
	Option 2: VFD controller for ultra high-cycle/high-speed application.		
Transformer	24VAC control circuit, supplies power to drive control relays with 15VA power available for external devices.		
Limit Adjustment	micro switches that control door travel. These limit switches are activated by fully adjustable screw type cams.		
Emergency Disconnect	Dual handle quick release disconnect carriage with re-engage feature to allow person to disengage operator drive chain from door for manual operation.		

Other Dimensions:

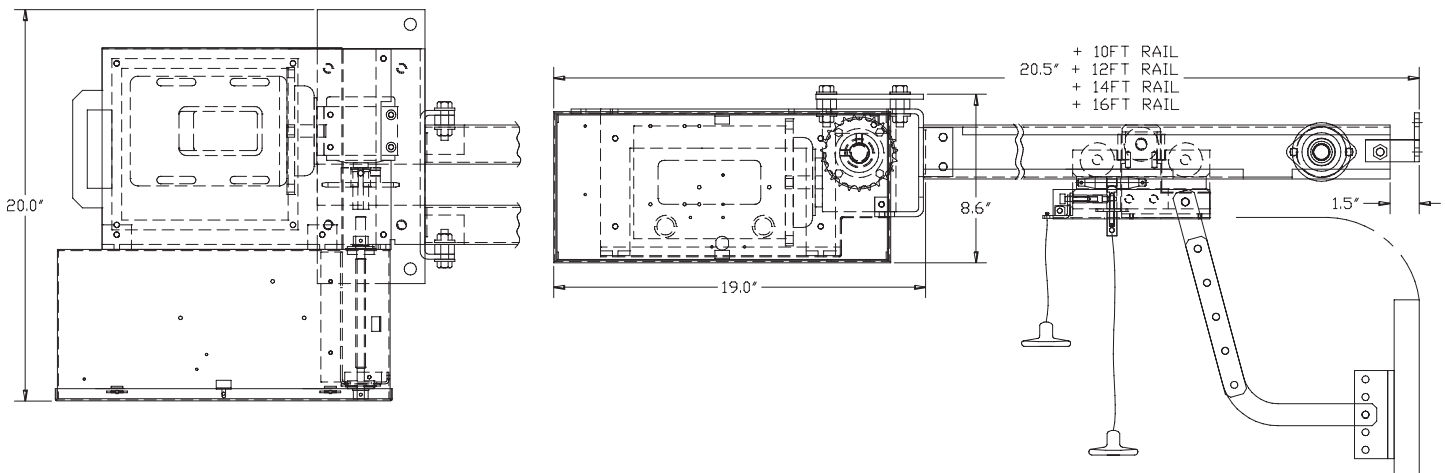

Important Safety Instructions

WARNING

TO REDUCE THE RISK OF INJURY OR DEATH:

- READ AND FOLLOW ALL INSTRUCTIONS
- Never allow children to operate or play with door controls. Keep the remote control (where provided) away from children.
- Personnel should keep away from a door in motion and keep the moving door in sight until it is completely closed or opened. **NO ONE SHOULD CROSS THE PATH OF A MOVING DOOR.**
- Test the door's safety features at least once a month. After adjusting the limit of travel, retest the door operator's safety features. Failure to adjust the operator properly may cause severe injury or death.
- For products having a manual release, if possible, use the manual release only when the door is closed. Use caution when using this release when the door is open. Weak or broken springs may cause the door to fall rapidly, causing severe injury or death.
- **KEEP DOORS PROPERLY OPERATING AND BALANCED.** See Door Manufacturer's Owner's Manual. An improperly operating or balanced door could cause severe injury or death. Have trained door systems technician make repairs to cables, spring assemblies, and other hardware.
- Press the "OPEN" device or use emergency disconnect mechanism if a person is trapped under the door.
- **SAVE THESE INSTRUCTIONS.** The owner or users must understand the safety and operation of door system. Insure that this installation manual be located close to the door system.

Important Installation Instructions

- READ AND FOLLOW ALL INSTALLATION INSTRUCTIONS
- Commercial door operators are never to be installed on a residential installation
- Install only on a properly operating and balanced door. A door that is operating improperly could cause severe injury. Have qualified service personnel make repairs to cables, spring assemblies, and other hardware before installing the operator.
- Remove all pull ropes and remove, or make inoperative, all locks (unless mechanically and/or electrically interlocked to the power unit) that are connected to the door before installing the operator.
- Install the door operator at least 8 feet or more above the floor if the operator has exposed moving parts.
- Do not connect the operator to the source of power until instructed to do so.
- Locate the control station: (a) within sight of the door, (b) at a minimum height of 5 feet so that small children cannot reach it, and (c) away from all moving parts of the door.
- Install the Entrapment Warning Placard next to the control station in a prominent location.
- For products having a manual release, instruct the end user on the operation of the manual release.
- Install non-contact entrapment protection devices (photocells) and/or contact entrapment protection devices (reversing edges). **NOTE:** photocells should be installed at no more than 6" from the floor. Edges should be installed on the leading edge of the door.

Installation Instructions

⚠ WARNING ⚠

DO NOT INSTALL THIS OPERATOR BEFORE READING THIS MANUAL CAREFULLY.

NOTE:

- Installation of operator must be done by a qualified installer. Door must be properly installed and working smoothly. Remove all door locks prior to installation.
1. Install control station away from all moving door parts, within sight of the door and a minimum of 5 ft (1.5 m) from the ground.
 2. Install entrapment warning sign next to control station.



3. Do not remove emergency release tag attached to disconnect handle.

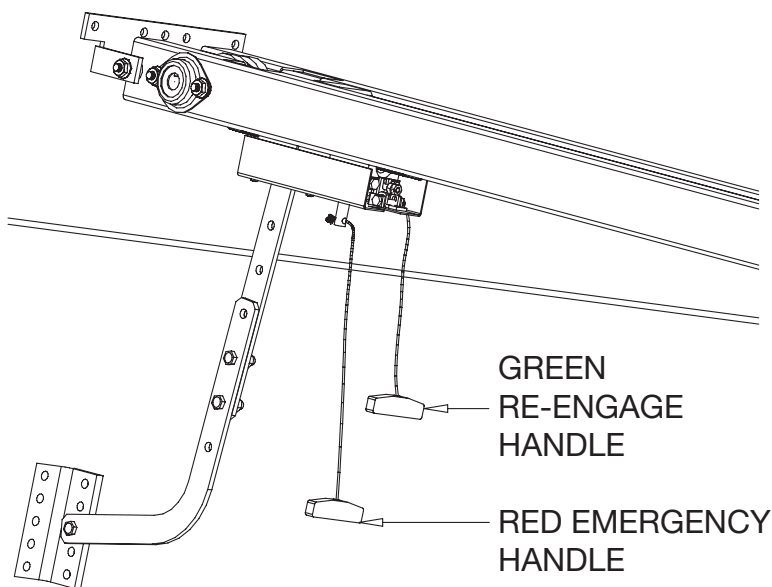

Wall Mounting Bracket and Operator Installation

NOTE: Trolley type operators should generally be mounted directly over the center of the door and the trolley rails should clear the tracks by 2-1/2" (6.5 cm). However, if interfering structures or other reasons do not allow for centered mounting, it is possible to install it up to 18" off-center for torsion spring doors.

1. With door closed, locate the center of door by measuring door width and mark a vertical line above the door (Fig A).
2. Open door and mark the center line of the door on the ceiling (Fig B).

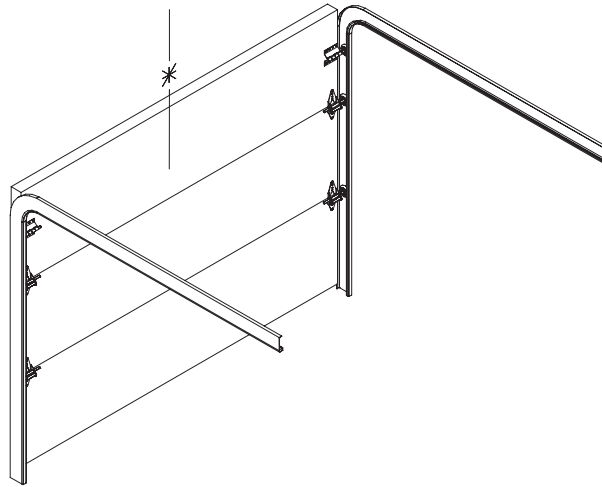

3. Determine the highest point of door travel by manually opening the door. Using a carpenter's level, project a line from where the top section of door reaches its highest point. Mark the spot where this line (high arc) intersects with the vertical line drawn earlier.

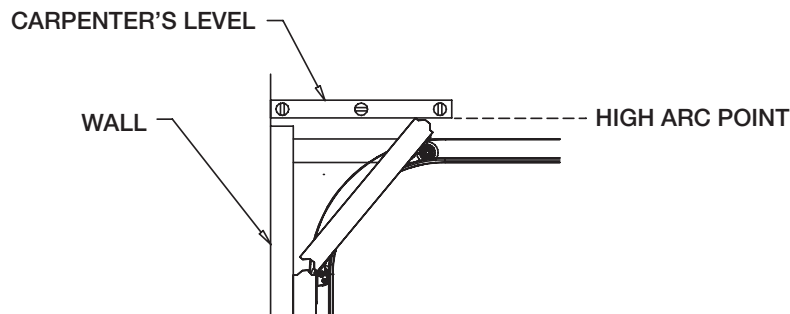

4. Close door. Lay out operator/rail assembly on ground (upside down) in front of door with door operator facing away from door.
5. Install curved trolley arm/door bracket to the trolley arm flat bar that is connected to the carriage. (Fig C). The trolley arm is adjustable so do not tighten bolts at this time.

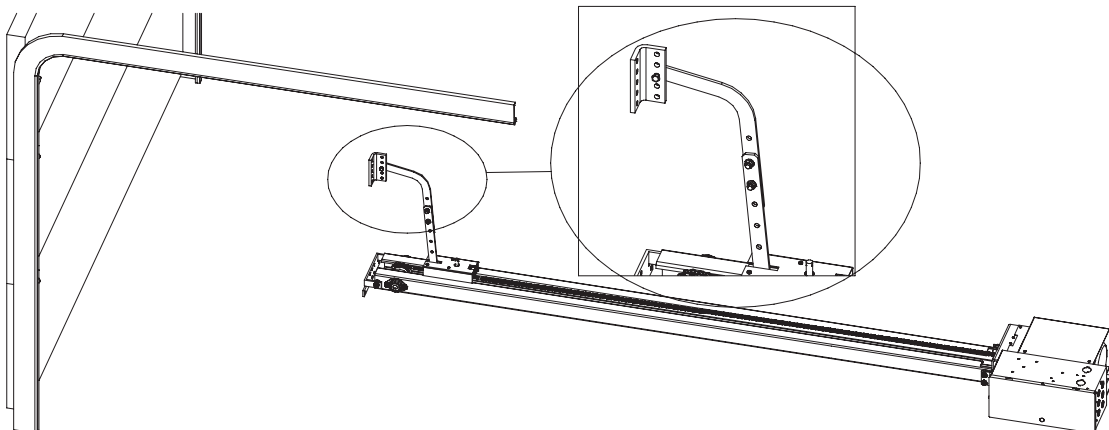

Wall Mounting Bracket and Operator Installation

7. Flip operator assembly so that carriage/trolley are facing the ground. While allowing motor side to rest on floor, lift rail assembly side of operator above door and align according to previously identified centerlines (Fig E). The wall mounting bracket has 5 holes for anchoring to wood block or angle iron or direct to wall. Bracket should be centered with door and positioned so that these holes are 2-1/2" (6.5 cm) above the high arc line of door. Secure wall mounting bracket by welding or using suitable hardware. Carefully open door. Align operator and rails with center of door. Using the door as support, shim the operator so that there is 3" (7.5cm) clearance between door and bottom of operator. Tighten wall mounting bracket bolts.

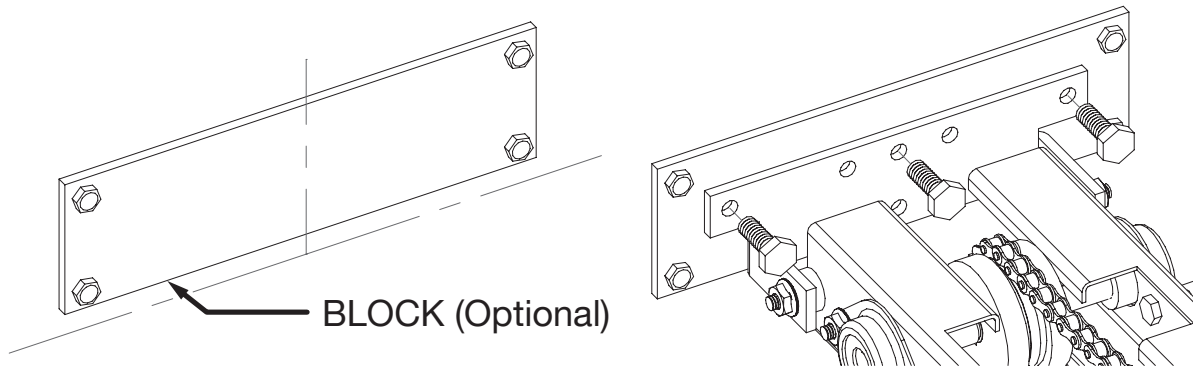

8. Swing the operator above the level of the door tracks and temporarily secure in place with a post, or rope or chain (Fig F). Carefully open door. Align operator and rails with center of door (as per previously identified centerline). Using the door as support, shim the operator so that there is 3" (7.5cm) clearance between door and bottom of operator. Tighten wall mounting bracket bolts.

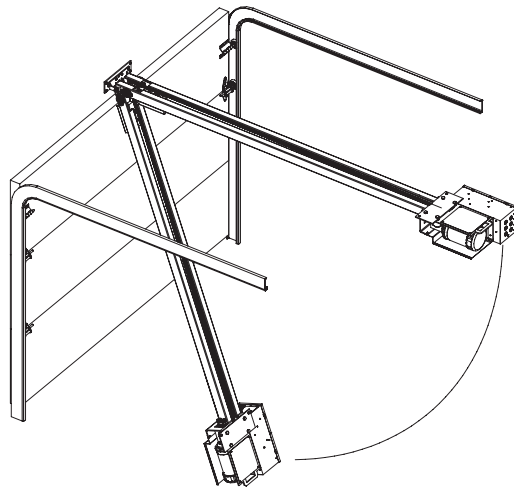

8. For low ceiling applications, bolt operator direct to ceiling as shown in Fig G.

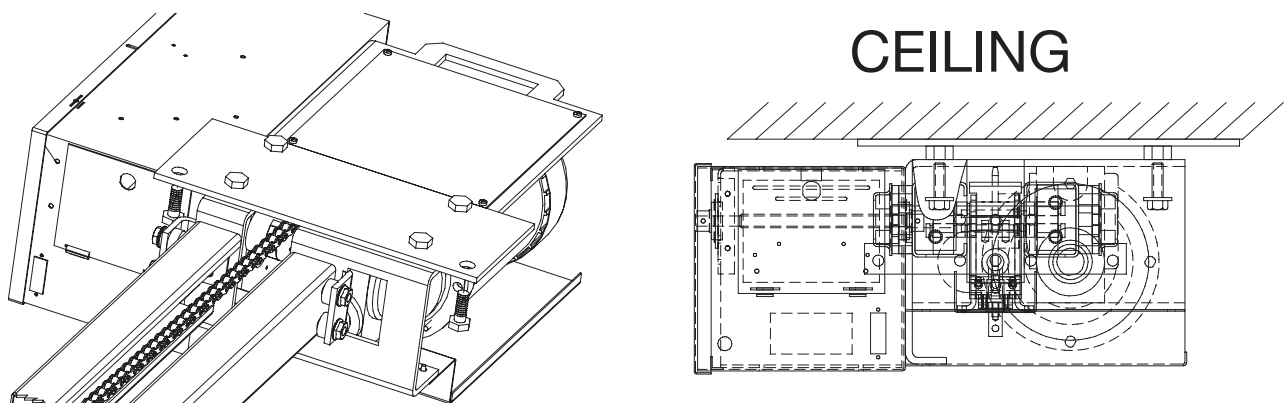

Wall Mounting Bracket and Operator Installation

10. For high ceiling applications, install hanging brackets (braces) from ceiling or structure to operator mounting plate.

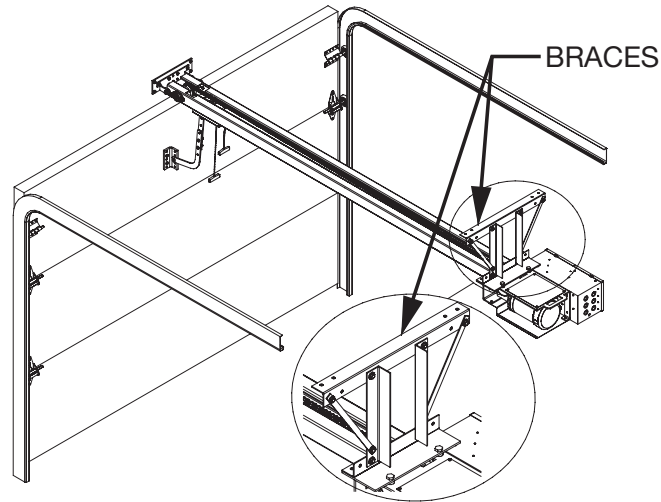

TROLLEY ARM INSTALLATION

1. With door closed and trolley carriage positioned close to end of rails, align the mounting holes of straight arm and curved arm so that pivot bolt on door bracket is in line with the top rollers of the door. Adjust length of 2-piece trolley arm accordingly. Using suitable hardware, Align door bracket with centerline of door and secure to door using suitable hardware.

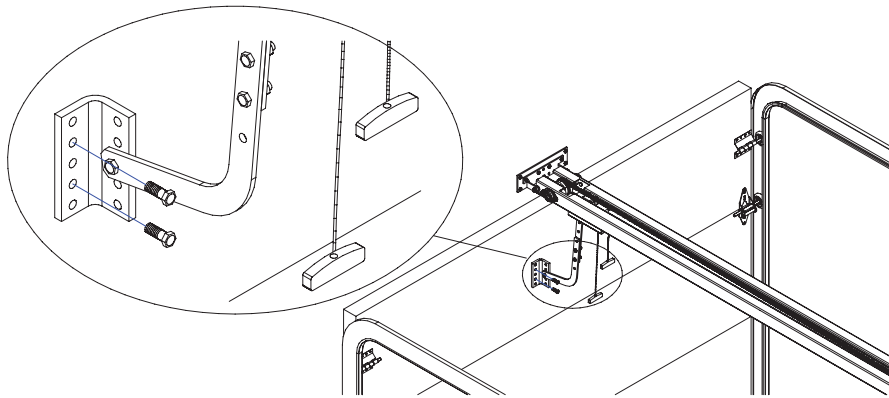

3. When properly installed the door arm should lean slightly away from door when door is fully closed.

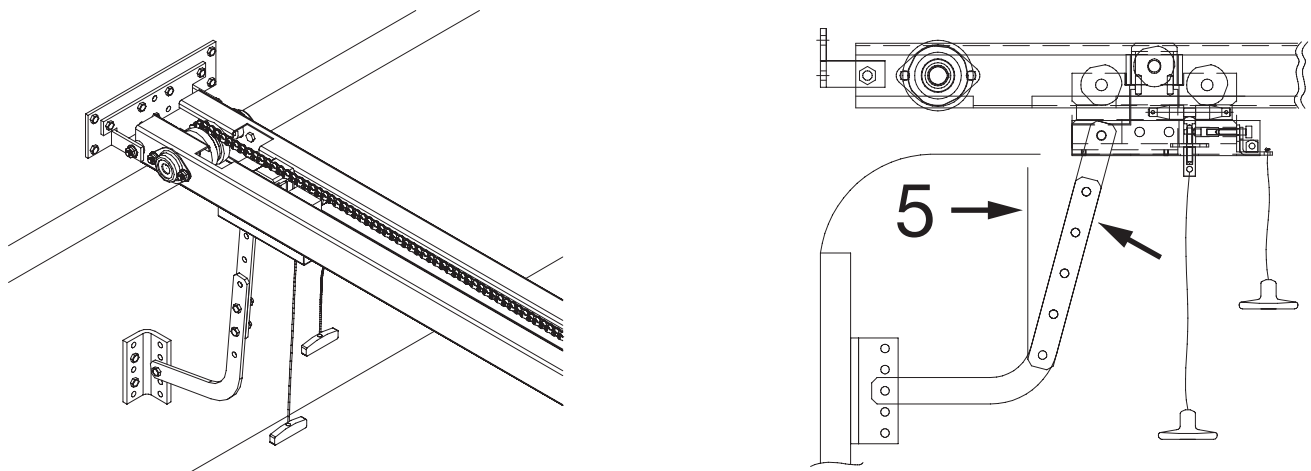

4. At this time, check all bolts for tightness.

Electrical Connections

These are 2 possible electrical control configurations for this operator:

- A) **Full Feature logic board Smart 10.0 (UL325 (2010) compliant)with auxiliary apt board.** Refer to Section A for electrical connections and logic board instructions. Refer to electrical drawings inside your operator control box or generic drawing MSL100APT-110V-3WM-WW, MSL300APT-WW and MSLC300APT-WW in the electrical drawings section at the end of this manual.
- B) **High speed VFD option:** Refer to section A as well as the separate diagrams and instructions located inside control box

IMPORTANT

- EACH INDIVIDUAL COMMERCIAL DOOR OPERATOR MUST HAVE IT'S OWN DEDICATED POWER SUPPLY
- NICE HIGHLY RECOMMENDS THAT EACH INDIVIDUAL COMMERCIAL DOOR OPERATOR HAVE AN EXTERNAL CIRCUIT BREAKER OR FUSED DISCONNECT

⚠ WARNING ⚠

COMPARE AVAILABLE POWER SUPPLY VOLTAGE TO OPERATOR NAMEPLATE PRIOR TO ELECTRICAL CONNECTION. FAILURE TO CONNECT APPROPRIATE POWER SUPPLY VOLTAGE MAY CAUSE SERIOUS DAMAGE TO OPERATOR.

Refer to electrical diagrams inside control box cover or at the end of this manual prior to connection of power supply or control station.

⚠ WARNING ⚠

TO REDUCE THE RISK OF INJURY OR DEATH:
ALL ELECTRICAL CONNECTIONS SHOULD BE MADE BY A QUALIFIED SERVICE PERSON
DO NOT ATTEMPT TO MAKE ELECTRICAL CONNECTIONS TO OPERATOR UNLESS POWER SUPPLY HAS BEEN DISCONNECTED AT FUSE BOX.
OPERATOR MUST BE CONNECTED IN ACCORDANCE TO LOCAL ELECTRICAL CODES AND GROUNDED TO GREEN GROUND LUG LOCATED INSIDE CONTROL BOX.

SECTION A: PRO-APTC(E)

Full feature logic board Smart 10.0 with auxiliary apt board (UL325 compliant)

Connection of Power Supply and Control Station

NOTE: The operator is shipped from the factory in the D1 mode setting (constant pressure open and close). The operator should remain in this mode until all connections and limit switch adjustments are completed.

Power Wiring: Connect primary power supply directly to the separate power terminal strip supplied using any of the 1-1/8" (2.85 cm) diameter holes provided on control box. Do not connect power supply directly to the circuit board.

- Single Phase:** Connect single-phase power supply to terminals L/L1 and N/L2 on three-pole power terminal strip (110V or 220V 1-phase).
- Three Phase:** Connect three-phase power supply to terminals L1, L2 and L3 on three-pole power terminal strip (208V, 230V, 380V, 460V or 575V).

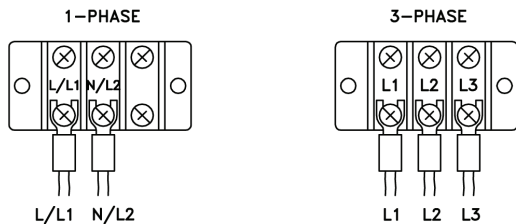

On Board O/C/S PBS Instructions

On-board Open, Close and Stop buttons are provided directly on the board for installation and troubleshooting purposes. In order to operate unit by on-board Open, Close, Stop buttons, the factory installed jumper (#1) between the COM and STOP terminals on the terminal strip must remain connected.

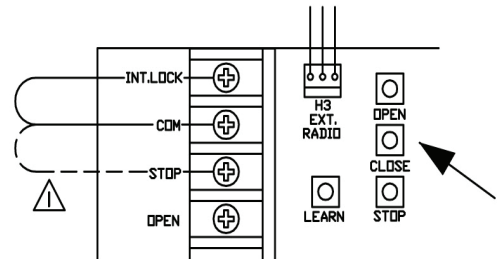

Motor Direction Verification

Make sure the mode of operation is selected to D1.

After electrical power connections are made, manually move door to mid-position. Using the on-board buttons press the "Open" button for several seconds and then press the "Stop" button. If door did not move in correct direction (or if limit cams not moving in correct direction towards the open limit switch) see below:

For Single-Phase Operators: The operators leave the factory with correct motor and limit shaft direction according to standard door installations. However, for special fire door, through wall mounting or other special door applications, the motor direction and limit switch direction may need to be reversed. A dipswitch (Dip #1) is provided to reverse direction of motor and limit switch direction. If motor direction is reversed, the open and close limit switches are automatically reversed. However, the advanced close limit switch needs to be manually changed. Disconnect the 2 wires from the advanced closed limit switch and re-connect to the auxiliary limit switch provided.

NOTE: Ensure that when the on-board open button is depressed and the door moves in the correct open direction that activation of the open limit switch illuminates the "OPEN LIMIT" LED and stops the door.

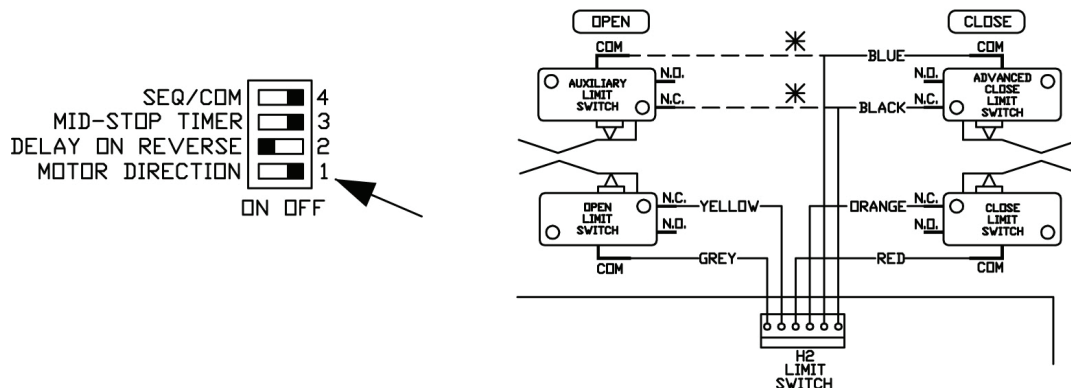

For 3-Phase Operators: If door moves in wrong direction, turn off incoming power and reverse any two of the three incoming power supply leads to correct rotation. Press the on board open button again. If door is going in the correct open direction, activate the open limit switch to ensure door stops. If door does not stop, turn off incoming power and interchange any two incoming power lines once again and slide dipswitch #1 to reverse motor direction. If motor direction is reversed, the open and close limit switches are automatically reversed. However, the advanced close limit switch needs to be manually changed. To do this, disconnect the 2 wires from the advanced limit switch and re-connect to the auxiliary limit switch provided.

NOTE: Ensure that when the on-board open button is depressed and the door moves in the correct open direction that activation of the open limit switch illuminates the “OPEN LIMIT” LED and stops the door.

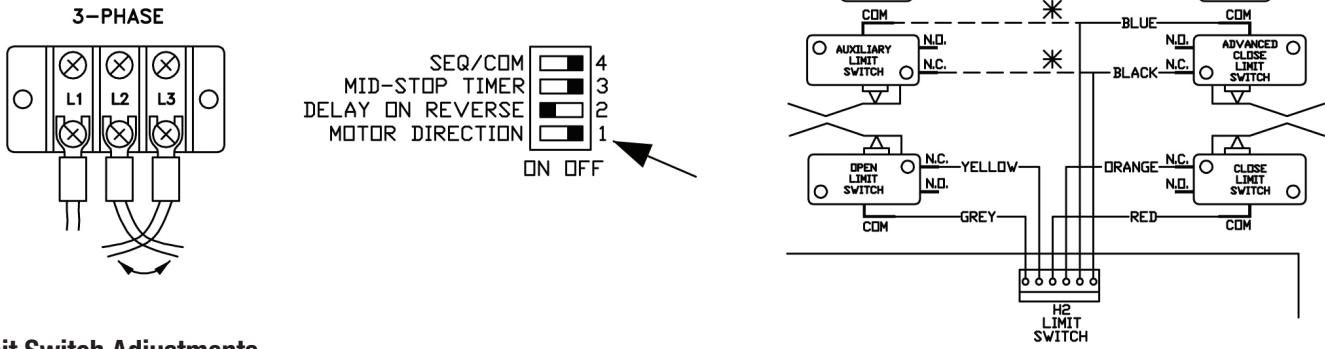

Limit Switch Adjustments

Once the motor rotation and limit cam direction have been verified, adjust the limit cam settings. Please note that when each limit switch is activated the corresponding LED will light up. Refer to operator installation manual for complete limit switch adjustment instructions.

Connection of External O/C/S PBS

Connect O/C/S PBS as shown in diagram.

NOTE: Jumper #1 must be removed after the external O/C/S PBS has been installed.

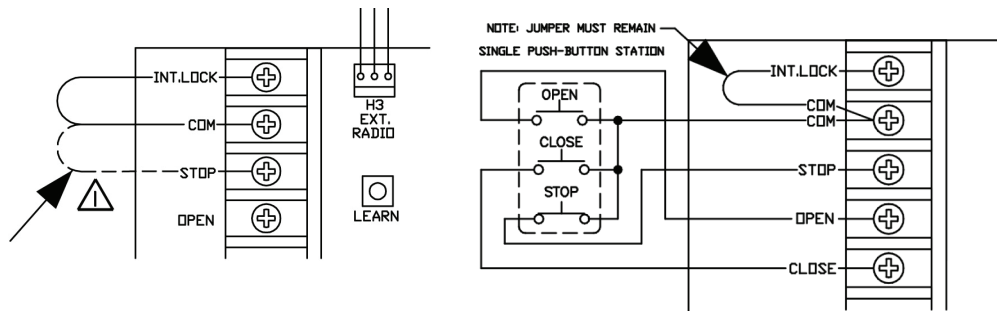

Failsafe Feature

A safety device failsafe feature is built into the logic board. The logic board has provisions to connect one primary monitored safety device as well as 1 or more secondary non-monitored safety device(s).

Primary monitored safety device

Nice monitored failsafe photo beams or Nice compatible monitored failsafe devices must be connected to terminals P1 and P2 as primary monitored safety device. Primary monitored safety device must be connected if momentary activation on close is required in B2, T and TS modes. If it is not connected in B2, T and Ts modes, door can only be closed by constant pressure on close and if constant pressure is removed before door reaches full close position, door reverses to full open.

NOTE: Only one monitored failsafe device can be connected to terminals P1 and P2.

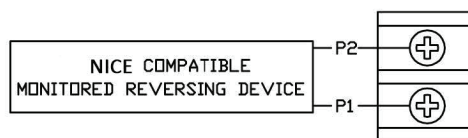
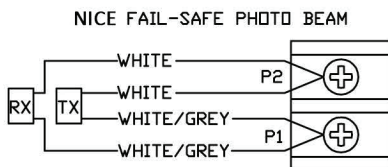

IMPORTANT!
NICE MONITORED SAFETY DEVICES MUST BE CONNECTED IF MOMENTARY ACTIVATION ON CLOSE IS REQUIRED.

Secondary Non-Monitored Safety Device(s):

A standard 2-wire safety edge, non-monitored photo beams or any other non-monitored reversing devices with a N.O contact can be connected to terminals S1 and S2 as secondary non-monitored safety device.

NOTE: More than one secondary non-monitored safety device can be connected to terminals S1 and S2.

IMPORTANT: Do not remove the resistor that is factory installed across terminals S1 and S2 unless installing a 4-wire electric edge.

4-wire electric edge:

A standard 4-wire electric edge can be connected across S1 and S2 terminals as a secondary safety device.

Remove the factory-installed resistor across terminals S1 and S2 when using a 4-wire electric edge.



Connection of External Single-Button Device

Connect an external single-button as shown in diagram. Please refer to “Modes of Operation” for the functionality of single-button.

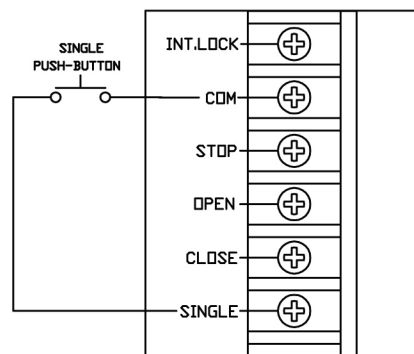

Modes of Operation

All operators leave the factory in the D1 mode setting; please read all modes of operation and determine which operational mode is desired.

B2 (Momentary on open and close):

- **Open Button:** Momentary activation opens the door. When door is closing, momentary activation reverses the door (OPEN OVERRIDE). Momentary contact from mid-stop opens the door to full open position. Constant activation when door is opening, bypass mid-stop if enabled.
- **Close Button:** Momentary on close.
- **Stop Button:** Momentary activation stops the door.
- **Single Button Device and Single Channel Transmitter, 3-Channel (1,2,3) Transmitter:**
 - » **SEQUENTIAL FUNCTION:** Open/Stop/Close/Reverse.
 - » **COMMERCIAL FUNCTION:** Open/Close/Reverse.
- **3-Button O/C/S Radio Transmitter:** Same as open, close and stop buttons.
- **Safety Devices:** When door is closing, momentary activation reverses the door.
- **Timer to Close:** N/A

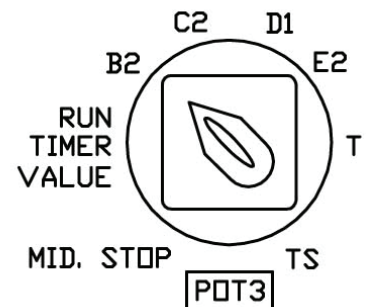

C2 (Momentary open, constant pressure close):

- **Open Button:** Momentary activation opens the door. When door is closing, momentary activation reverses the door (OPEN OVERRIDE). Momentary contact from mid-stop opens the door to full open position. Constant activation when door is opening, bypass mid-stop if enabled.
- **Close Button:** Constant pressure on close. Door will stop when button is released
- **Stop Button:** Momentary activation stops the door.
- **Single Button device:**
 - » **SEQUENTIAL FUNCTION:** Open/Stop/Constant pressure on close/stop.
 - » **COMMERCIAL FUNCTION:** Open/Constant pressure on close/stop.
- Single channel transmitter, 3-channel (1,2,3) transmitter and 3-button O/C/S radio transmitter. Momentary activation opens the door. Momentary contact of OPEN button on 3-button (O/C/S) radio transmitter from mid-stop opens the door to full open position. Cannot close the door.
- **Safety Devices:** When door is closing, momentary activation reverses the door.
- **Timer to Close:** N/A

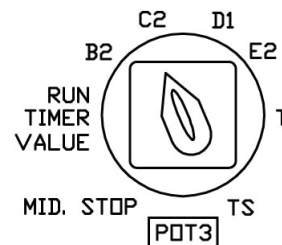

D1 (Constant pressure on open and close):

- **Open Button:** Constant pressure opens the door. Door stops when constant pressure is released. Constant pressure from mid-stop opens the door to full open position.
- **Close Button:** Constant pressure on close. Door will stop when button is released
- **Single Button device, single channel transmitter, 3-channel (1,2,3) transmitter and 3-button (O/C/S) radio transmitter:** N/A
- **Safety Devices:** When door is closing, momentary activation reverses the door.
- **Timer to Close:** N/A

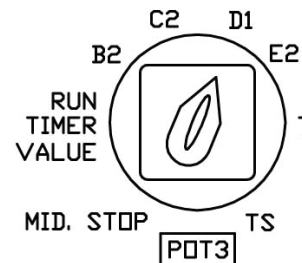

E2: (Momentary on open, constant pressure on close with roll-back feature)

- **Open Button:** Momentary activation opens the door. When door is closing, momentary activation reverses the door. Momentary contact from mid-stop opens the door to full open position. Constant activation when door is opening, bypass mid-stop if enabled.
- **Close Button:** Constant pressure on close. Door reverses to full open when button is released.
- **Single Button:**
 - » **SEQUENTIAL FUNCTION:** Open/Stop/Constant pressure on close/stop.
 - » **COMMERCIAL FUNCTION:** Open/Constant pressure on close/reverse.
- **Single channel device, 3-channel (1,2,3) transmitter and 3-button (O/C/S) radio transmitter:** Momentary activation opens the door. Momentary contact of OPEN button on 3-button (open/close/stop) radio transmitter from mid-stop opens the door to full open position. Cannot close the door.
- **Safety Devices:** When door is closing, momentary activation reverses the door.
- **Timer to Close:** N/A

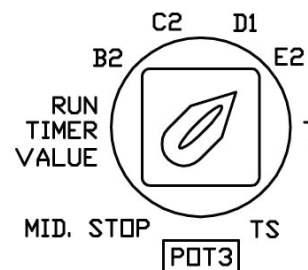

T: (Momentary on open and close, timer to close, SAFETY ACTIVATION & STOP BUTTON DISABLE TIMER)

- **Open Button:** Momentary activation opens the door. When door is closing, momentary activation reverses the door. Momentary contact from mid-stop opens the door to full open position. Momentary contact at full-open refreshes the timer if enabled at full open. Momentary contact at full open position re-activates the timer if timer is disabled previously by stop button or safety device. Constant activation when door is opening, bypass mid-stop if enabled.
- **Close Button:** Momentary on close.
- **Single Button:** If door is opening or closing, momentary activation stops the door. Momentary activation while timer is counting at mid-stop or full open deactivates the timer.
- **Single button device, single channel and 3-channel (1,2,3) radio transmitter:**
 - » **SEQUENTIAL FUNCTION:** Open/Stop/Close/Reverse.
 - » **COMMERCIAL FUNCTION:** Open/Reverse/Refresh timer.
- **3-button (O/C/S) Transmitter:** Same as open, close, stop buttons.
- **Safety Devices:** When door is closing, momentary activation reverses the door to full open AND DISABLES TIMER.

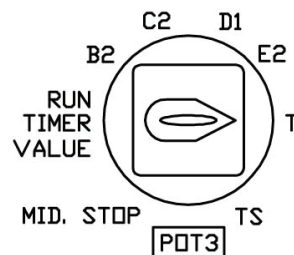

- **Timer to Close:** Closes the door from mid-stop or full open. Momentary activation of stop button will deactivate the timer. When door is closing, momentary activation of safety devices will reverse the door to mid-stop (if enabled) or full open and deactivates the timer. Timer resumes its normal operation upon momentary activation of open push button or once the close cycle is completed. If mid-stop is enabled and “Timer from mid-stop only” dip-switch is ON, timer is enabled only from mid-stop and disabled from full open. If mid-stop is enabled and “Timer from mid-stop only” dip-switch is OFF, timer is enabled from full open and mid-stop.

TS: (Momentary on open and close, timer to close secure, STOP BUTTON DISABLES TIMER)

- **Open Button:** Momentary activation opens the door. When door is closing, momentary activation reverses the door. Momentary contact from mid-stop opens the door to full open position. Momentary contact at full-open refreshes the timer if enabled at full open. Momentary contact at full open position re-activates the timer if timer has been disabled previously by stop button. Constant activation when door is opening, bypass mid-stop if enabled.
- **Close Button:** Momentary on close.
- **Stop Button:** If door is opening or closing, momentary activation stops the door. Momentary activation while timer is counting at mid-stop or full open deactivates the timer.
- **Single button device, single channel transmitter and 3-channel (1,2,3) radio transmitter:**
 - » **SEQUENTIAL FUNCTION:** Open/Stop/Close/Reverse.
 - » **COMMERCIAL FUNCTION:** Open/Reverse/Refresh timer.
- **3-button O/C/S radio transmitter:** Same as open, close, stop buttons.
- **Safety Devices:** When door is closing, momentary activation reverses the door. Momentary activation refreshes the timer to close.
- **Timer to Close:** Closes the door from mid-stop or full open. Momentary activation of stop button will deactivate the timer. Timer resumes its normal operation upon momentary activation of open push button or once the close cycle is completed. If mid-stop is enabled and “Timer from mid-stop only” dip-switch is ON, timer is enabled only from mid-stop and disabled from full open. If mid-stop is enabled and “Timer from mid-stop only” dip-switch is OFF, timer is enabled from full open and mid-stop.

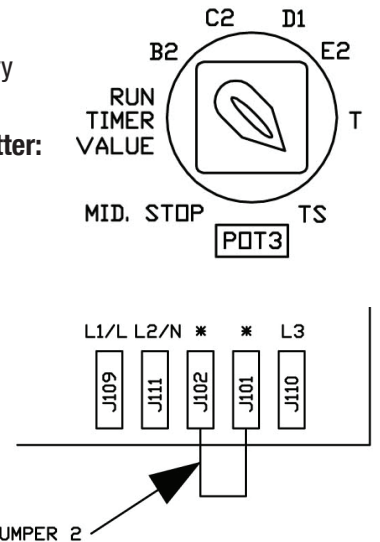

WARNING: When replacing the logic board in a single-phase operator. Make sure that Jumper 2 is installed properly before operating the door. Failure to do this will damage the logic board.

Programming Instructions

NOTE: ALL PROGRAM FUNCTIONS CAN BE INITIATED BY TURNING SELECTOR SWITCH TO THE DESIRED SETTING AT ANY POINT DURING OPERATION EXCEPT FOR THE MID STOP and RUN TIMER MODE. PROGRAMMING MUST START FROM THE FULL CLOSED POSITION.

Run-Timer Setup

Run-timer is the maximum amount of time the motor will run upon receiving an open or close command. The factory default value for run-timer is 45 seconds.

NOTE: Limits must be set prior to setting run-timer.

Modify the run-timer from factory default:

1. Close the door to full close position.
2. Set the selector dial to “Run-timer” position. The “Delay On Close Timer”. LED should blink.
3. Press open button. Wait until door reaches full open position. The run timer value is set to the time taken for the door to travel from full close position to full open position plus 5 seconds.
4. Set the selector dial to the desired mode of operation.

Modify the run-timer to factory default:

1. Close the door to full close position.
2. Set the selector dial to “Run-timer” position.
3. Press **Stop Button**. The run-timer is modified to the factory default value. Then set the selector dial to the desired mode of operation.

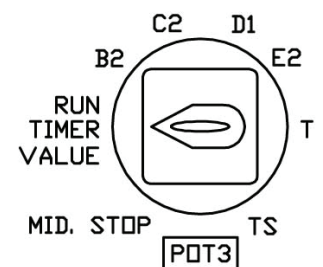

Mid-Stop Setup

Mid-Stop feature can be used to open the door to a preset point prior to full open position.

NOTE: Limits must be set prior to setting mid-stop position.

To Activate Mid-Stop:

1. Close the door to full close position.
2. Set the selector dial to “Mid-Stop” position. “Mid-Stop” LED starts blinking.
3. Press open push button. Door opens. Once the door reaches the desired mid-stop position, stop the door by activating stop push button.
4. Set the selector dial to the desired mode of operation.

NOTE: When door opens to the programmed mid-stop position, “Mid-Stop” LED will illuminate.

To De-activate the Mid-Stop position:

1. Close the door to full close position.
2. Set the selector dial to “Mid-Stop” position.
3. Press the stop button, Mid-Stop is deactivated.

Modify mid-stop position:

To modify the current mid-stop position, follow the same steps to activate mid-stop. The new mid-stop position will override the old mid-stop position.

Timer to Close Setup

Timer to close is enabled only in TS and T modes of operation. To adjust the timer value turn POT1 clockwise to the desired value. The minimum value for timer to close is 3 seconds and the maximum value is 300 seconds.

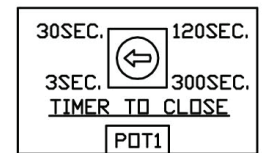

Delay on Close Setup (only for use with optional apartment board)

Delay on close timer can be used to delay the closing of the door in B2 and TS modes of operation. This timer is deactivated in C2, D1, E2 and T modes of operation. Delay on close timer is OFF when the “Delay on close” dial is set to OFF position. To adjust this timer, rotate the dial clockwise to the desired value. The minimum value for delay on close timer is 1 second and the maximum value is 60 seconds. It is recommended to use this feature in apartment applications where RED and GREEN traffic lights are used.

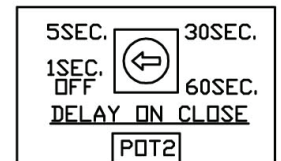

NOTE: In TS mode, the “Delay on close” timer starts only once the “Timer to close” has finished counting. Unless a delay on close is required this dial should be rotated to the OFF position. If left in any other position but OFF, activation of close button will delay to POT2 amount of time.

On-Board Receiver Programming

This logic board has a built-in 372 MHz radio receiver and can only be used with Nice single button, 3-button (OPEN/CLOSE/STOP) and 3-channel radio transmitters.

Installing the Antenna

Direct Connection:

Attach the antenna when supplied with the operator to the F connector on the control box. For best reception, keep antenna wire straight and away from metal objects.

Indirect connection (Mounting the antenna at a remote location):

1. Connect coax extension cable (optional) to the F connector on the control box.
2. Route cable inside metal enclosure.
3. Route and secure cable away from moving parts.
4. Mount antenna holder (not provided) outside enclosure.
5. Attach antenna to extension wire.
6. Position antenna wire straight. For best reception, keep antenna away from metal.

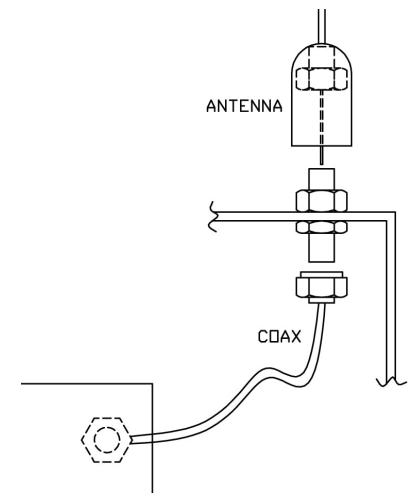

NOTE: Do not route coax cable near any moving parts of the operator. If necessary, secure coax wire away from any moving part

Connection of 110V Red and Green Traffic Lights

Refer to electrical schematic for connection of traffic lights

The operator is pre-wired to connect and activate 110V RED and GREEN traffic lights as per the following sequence:

- Green light is ON when the door is fully open.
- Red light is ON when door is in motion or stopped in any position other than fully open or fully closed. When “Delay on close” timer is activated, Red light turns ON for the adjustable period of time set by the “DELAY ON CLOSE” dial before the door closes. Please refer to “DELAY ON CLOSE SETUP” on page 16 of this manual.
- Traffic lights are OFF when door is fully closed.

The traffic lights can be connected to the apartment board as shown in the following diagram.

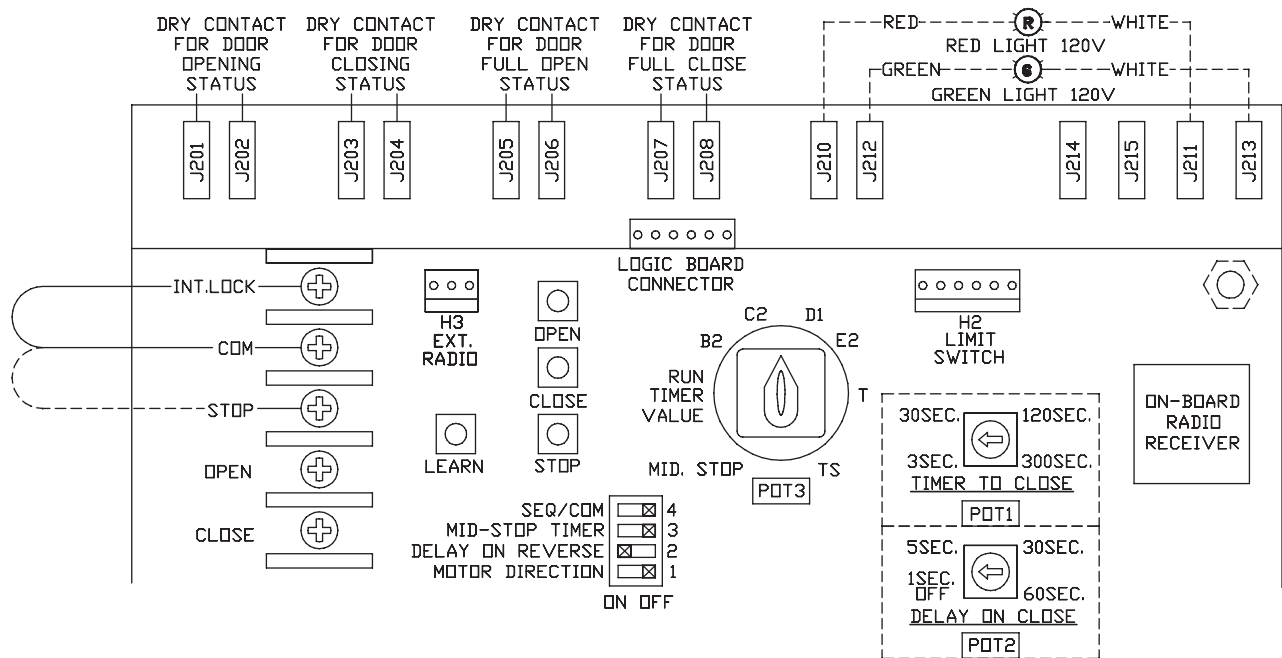

The following dry contacts are available on the apartment board for door status indication:

- Dry contact status for door opening status: Contact closes when door is opening.
- Dry contact status for door closing status: Contact closes when door is closing.
- Dry contact for door full open status: Contact closes when door is fully open.
- Dry contact for door full close status: Contact closes when door is fully closed.

Nice recommends the following setup and traffic light sequence in a typical apartment/condo installation:

- Mode of operation : TS (Set timer to close dial to desired value)
- Delay on close : Set the dial as required for the application
- Traffic lights are OFF when door is fully closed
- RED light turn ON upon activation of an open command and remains ON until door is fully open
- Green light turns ON and Red light turns OFF when door is fully open.
- Green light remain ON until timer to close timer is counting.
- “Delay on close” timer turns ON once the timer to close timer stops counting. At this time, Green light turns OFF and Red light turns ON. Red light remains ON while “delay on close” timer is counting.
- Door closes after the Delay on close timer finishes counting. Red light is ON when door is closing and remains ON until door is fully closes.

Programming the On-Board Radio Receiver

Warning: During programming, door operator will activate. Keep people and objects away from door.

1. Connect power to door operator.
2. Press and release the learn button once. The receiver's LED will turn on.
3. To program a single button transmitter, press the button on the transmitter. The receiver's LED will blink twice indicating a successful programming.
4. Press the button on the transmitter once more to confirm operation of the door operator.
5. To program a 3-channel (1,2,3) transmitter, press any of the 3 buttons on the transmitter. The receiver's LED will blink twice indicating a successful programming. Press the same button on the transmitter to confirm operation of the door operator. This button is now associated with that particular receiver. You can repeat the programming process for the other two buttons to control two other receivers.
6. To program a 3-button (O/C/S) transmitter, press OPEN button on the transmitter. The receiver's LED will blink twice indicating a successful programming. Press the OPEN button on the transmitter to confirm operation of the door operator. OPEN, CLOSE and STOP buttons on the transmitter can be used to open, close and stop the operator respectively.
7. Test range of transmitter. Repositioning antenna may provide greater range.
8. Repeat transmitter-programming steps for additional transmitters.

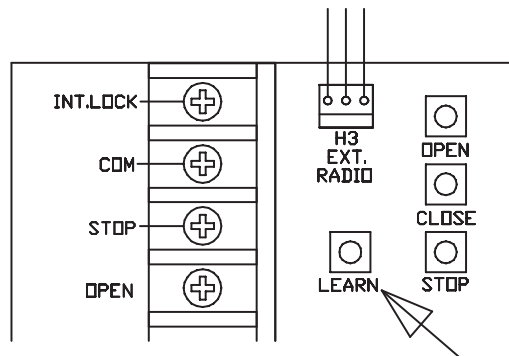

Operation

1. Press and release the button on Nice transmitter.
2. Receiver LED will light momentarily and door will cycle.

To Erase all Learned Transmitters

1. Press and hold down the LEARN button.
2. After 5 seconds, the LED will blink for 5 seconds.
3. Release the LEARN button during the time LED is blinking.
4. After you released the button, the LED will blink 5 times indicating all transmitters are erased from the receiver's memory.

NOTE: A maximum of 20 transmitters can be programmed for the same receiver. If more than 20 are required, consult factory.

Replacing Remote Control Batteries

The batteries (lithium, 3V) should produce power for up to 5 years. To replace the battery, open the transmitter by removing the screws on the back of the transmitter. Match the positive and negative terminals of the battery to the positive and negative terminals of the transmitter.

NOTE: The receiver and transmitter comply with part 15 of the FCC rules with RSS-210 of industry Canada. Operation is subject to the following two conditions: (1) this device may not cause harmful interference, and (2) this device must accept any interference received, including interference that may cause undesired operation.

NOTE: If an external radio-receiver (Nice or other) is used instead of the built-in radio receiver, it is highly recommended to disconnect the co-axial cable from the logic board.

NOTE: When using any external receiver, the Nice on-board receiver should not be used.

Dip-Switch Setup

DIP-SWITCH	ON	OFF	NOTE
SEQ/COM	Single button and radio in SEQ mode	Single button and radio in COM mode	
Mid-stop Timer	Timer is enabled from mid-stop only	Timer is enabled from both mid-stop and full open	T or TS mode can be selected to enable a timer for mid-stop
Delay on reverse	Delay on reverse is 1.5 seconds	Delay on reverse is 0.5 seconds	Nice recommends 1.5 second delay on reverse for all applications
Motor direction	Reverse motor direction	Standard motor direction	See NOTE ** below

NOTE: If motor direction is reversed, the open and close limit switches are automatically reversed. However, the advanced close limit switch needs to be manually changed. To do this, disconnect the 2 wires from the advanced closed limit switch and re-connect to the auxiliary limit switch provided.

Status LED

LED	Status	Cause
Fault	ON	<ul style="list-style-type: none"> » Primary safety devices not connected to P1 & P2 or not functioning properly » Safety devices are activated » 10k Ohm resistor (between S1 & S2) removed or faulty
Fault	Blinking	<ul style="list-style-type: none"> » Interlock is activated. » Interlock jumper is not connected
Run-out-timer	ON	Run-out timer has elapsed
Delay on close timer	Blinking	<ul style="list-style-type: none"> » Delay on close timer is counting » Selector dial is set to Run-timer
Timer to close	Blinking	Timer to close is counting.
Safety/Photo	ON	<ul style="list-style-type: none"> » Primary safety devices not connected to P1 & P2 or not functioning properly » Safety devices are activated » 10k Ohm resistor (between S1 & S2) removed or faulty
Mid. Stop	ON	Door is at Mid-stop position.
Close Limit	ON	Close limit switch is activated.
Open Limit	ON	Open limit switch is switched
Stop PB	ON OFF	<ul style="list-style-type: none"> » Stop button connected and functioning » Stop push button is activated (or the stop circuit is open).
Close Relay	Blinking	<ul style="list-style-type: none"> » Door is closing » Close relay is activated
Open Relay	Blinking	<ul style="list-style-type: none"> » Door is opening. » Open relay is activated.
Power	ON	24 VAC power to logic board is ON.

FAULT	<input type="checkbox"/>
RUN-OUT TIMER	<input type="checkbox"/>
DELAY ON CLOSE TIMER	<input type="checkbox"/>
TIMER TO CLOSE	<input type="checkbox"/>
SAFETY/PHOTO	<input type="checkbox"/>
MID. STOP	<input type="checkbox"/>
CLOSE LIMIT	<input type="checkbox"/>
OPEN LIMIT	<input type="checkbox"/>
STOP P.B.	<input type="checkbox"/>
CLOSE RELAY	<input type="checkbox"/>
OPEN RELAY	<input type="checkbox"/>
POWER	<input type="checkbox"/>

SECTION B: For all Operator Control Types

Limit Switch Adjustment

Adjustment of door travel is done by moving the limit cams on the threaded shaft. The position of the 4 limit switches are factory adjusted and should not be altered. The limit switches are:

- **“Open” limit switch:** End of door travel in the fully open position
- **“Closed” limit switch:** End of door travel in the fully closed position
- **“Advanced Open” or “Auxiliary advanced closed” limit switch:**
 - A) For relay logic operators this advanced open limit switch is used for open/close devices or timer to close features.
 - B) For logic board this auxiliary closed limit switch is used for open/close devices used when motor direction is reverse of standard.
- **“Advanced Closed” Limit switch:** Used to prevent reversing device from reversing door when door is almost fully closed.

⚠ WARNING ⚠

TO REDUCE THE RISK OF INJURY OR DEATH: DO NOT ATTEMPT TO MAKE LIMIT SWITCH ADJUSTMENTS UNLESS POWER HAS BEEN ELECTRICALLY DISCONNECTED.

To adjust door travel:

1. **Open cycle:** Depress cam plate and spin “Open” limit cam away from “Open” limit switch to increase door travel or spin “Open” limit cam towards the “Open” limit switch to decrease door travel. After each adjustment ensure that cam plate fully engages in slots of both limit nuts.
2. Adjust “Open” limit cam so that door stops at the desired fully open position.
3. **Close cycle:** Depress cam plate and spin “Close” limit cam away from “Close” limit switch to increase door travel or spin “Close” limit cam towards the “Close” limit switch to decrease door travel. After each adjustment ensure that cam plate fully engages in slots of both limit nuts.
4. Adjust “Close” limit cam so that door stops at the desired fully closed position.

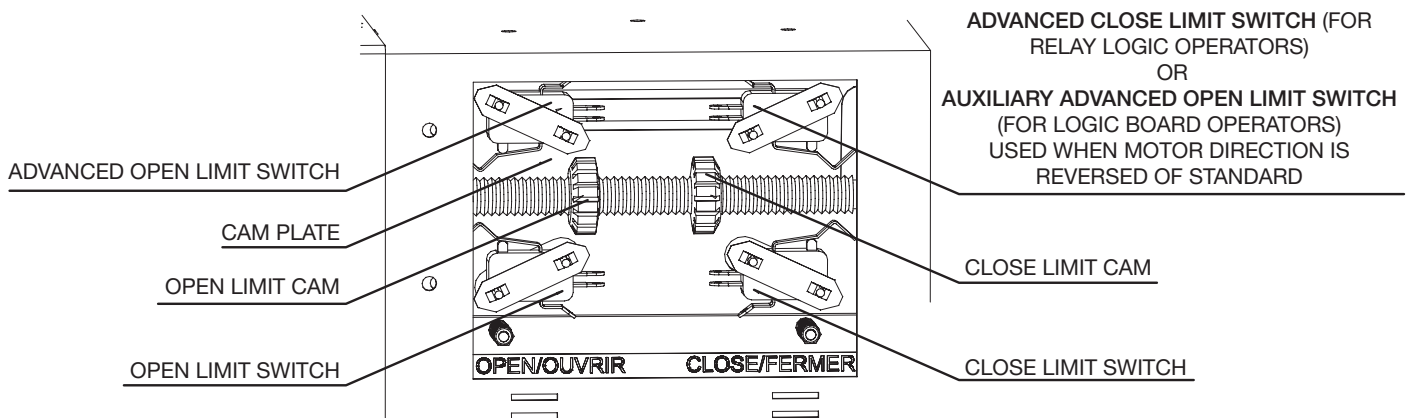

SECTION C: For Operators with Interface Modules or Logic Boards

Installation of Photocells

⚠ WARNING ⚠

Nice MV00298 NEMA-4 and FRABA MK00697 NEMA 4/4X infrared photo systems are for use only with Nice logic board operators or relay logic operators equipped with the Nice failsafe interface module. Use of this device on other than recommended operators can lead to severe or fatal injury. Follow these instructions carefully.

IMPORTANT

For momentary activation on close, the Nice photocells (or a Nice 2-wire monitored edge), must be installed as part of the operator system. If a Nice 2-wire monitored edge or the Nice infrared photocells system is not installed (or not operating correctly), the operator will only operate in fault mode (constant pressure to close).

READ and FOLLOW all installation instructions.

1. Before installing the photo beam, read the door or gate operator's instruction manual fully, so you are aware of all of the unit's functions and features.
2. Wear protective gloves and eye protection when using tools.
3. Before installing photo beam, disconnect all power to door operator to prevent unintended operation and have the door full open or close.
4. Do not reconnect power to the door or gate operator until instructed to do so.
5. Only install photobeams on a properly functioning door or gate operator.
6. Installation and wiring must comply with local building and electrical codes. This device is not intended and must not be installed in an explosive environment.

⚠ WARNING ⚠

Keep fingers and other body parts away from all moving parts of the door and gate operator system while the system is being operated.

⚠ WARNING ⚠

To prevent unintended operation, disconnect power to the door or gate operator prior to installing the photobeam system.

NICE N-4 monitored Through beam PHOTOCELL (MV00298)

NOTE: The MV00298 photocell system has a maximum range of 30 ft.

Installation

NOTE: Photo beams should be mounted as close to the door track inside the door to offer maximum entrapment protection.

Wall or Floor Mount Installations

1. Select a location on the wall no more than 6 inches from the floor or on the ground to install photocell mounting flanges on the left and right side of the door. Both brackets must be mounted at the same height for proper alignment.
2. Drill holes in the wall or floor and attach photocells using appropriate hardware as shown in Fig. 1.

FIGURE 1

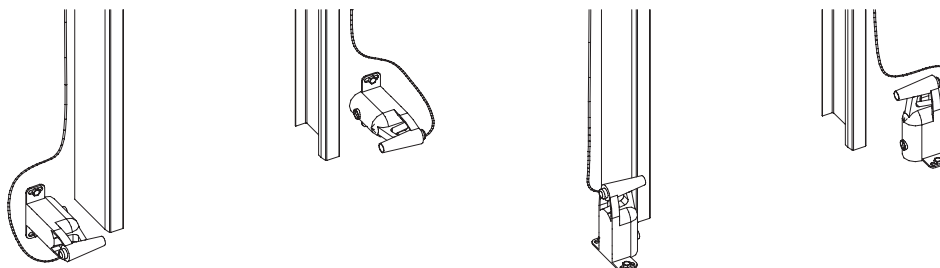

3. Pair the two white wires and the two black wires together from transmitter and receiver to a junction box.
4. Connect these paired wires to the P1 and P2 terminals on the logic board (or interface module if applicable) as shown in Figure 3.

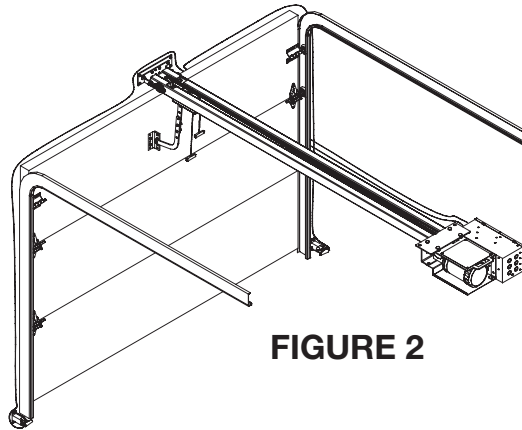

FIGURE 2

5. Pair the two white wires and the two white/gray wires together from transmitter and receiver.
6. Connect these paired wires to the P1 and P2 terminals on the logic board (or interface module if applicable) as shown in Figure 3.

FIGURE 3

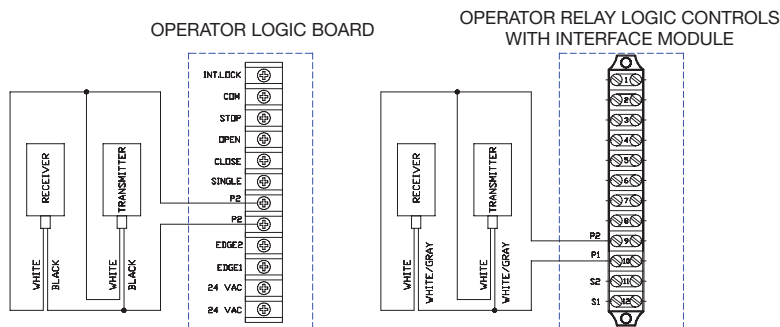

Photo System Operation

Monitored photocells must be connected for the door to close in momentary mode (unless a Nice monitored 2-wire edge is connected). When the photo system is properly installed and aligned, the infrared beam will detect any obstruction in the path of the beam. Upon detecting an obstruction, closing door will stop and reverse to full open. The Nice operator control circuit continuously monitors the correct operation of the photo system. If the photocells are not connected or not functioning properly, the operator will go into fail-safe mode and closing door will reverse to full open. In fail-safe mode door can only be closed by constant pressure on close.

1. Turn the power on to the operator. Align transmitter and receiver by adjusting height of the fixture (Fig. 4).
2. Utilize LEDs on photocells for alignment and trouble shooting. Make sure to tighten photocells after alignment is completed.
 - » Transmitter Green (ON), Receiver Green (ON), Receiver Red (OFF): Normal operation
 - » Transmitter Green (OFF), Receiver Green (OFF): No power. Verify wiring
 - » Receiver Red LED (ON): Obstruction (Normal when beam is broken)
 - » Receiver Green (Flashing): Misalignment or out of range

To test the photo system: Open the door to full open position. Close the door. When door is closing, obstruct the beam. The door should stop and reverse

FIGURE 4

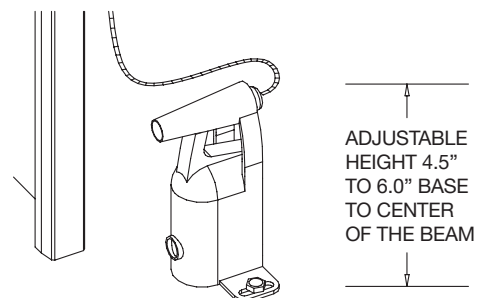

FRABA N-4/4 Thru-Beam Photocell (MK00697)

NOTE: The MK00687 photocell system has a maximum range of 45 ft. Sun Visor protector optional.

1. Select a location on the wall no more than 6 inches from the floor to install wall mounting brackets on the left and right side of the door. Both brackets must be mounted at the same height for proper alignment.
2. Drill holes in the wall and attach brackets to the wall using screws provided as shown in Fig. 4.

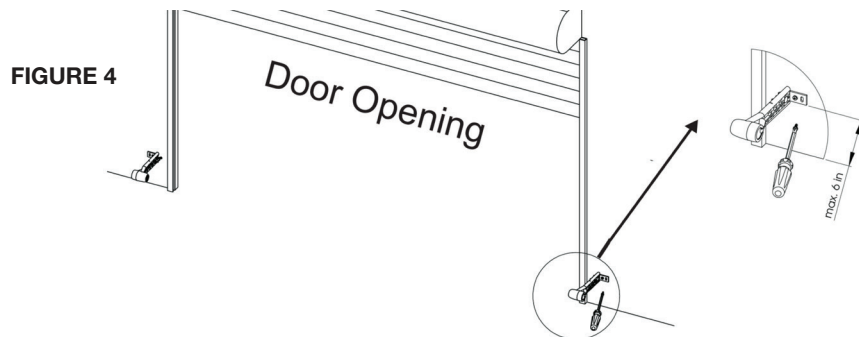

3. Plug sensors into flexible adapters as shown in Fig. 5. Please note that the 2 brackets are not identical. The receiver (Rx) must be installed into the receiver adapter and the transmitter (Tx) must be installed into the transmitter adapter (Fig. 6).

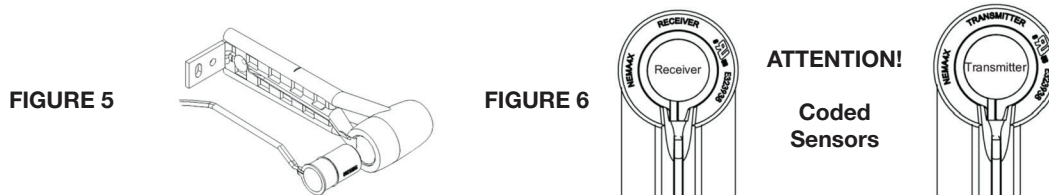

4. Pair the two black and the two black with white tracer wires together from transmitter and receiver. Connect these paired wires to the P1 and P2 terminals on the logic board (or interface module if applicable) as shown in Fig. 7. Use minimum 18 gauge wires and secure the wires to wall or ceiling.

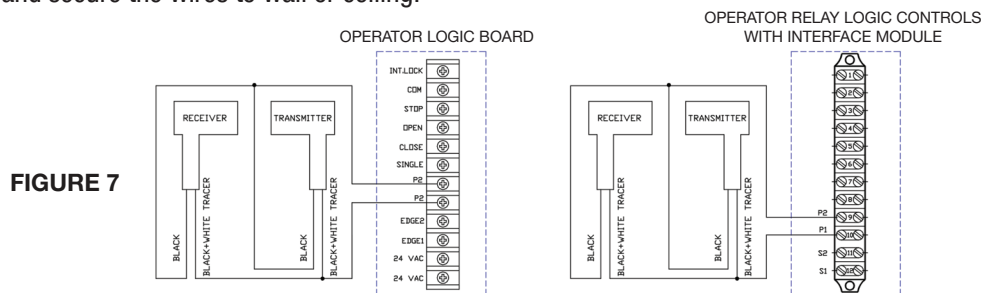

5. Turn the power on to the operator. Align transmitter and receiver by adjusting angle and height of the fixture (Fig. 8A and 8B).

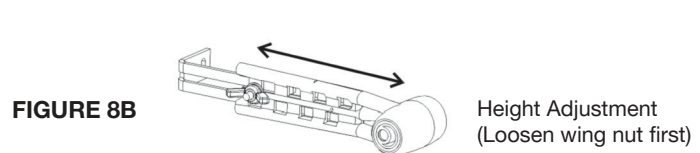
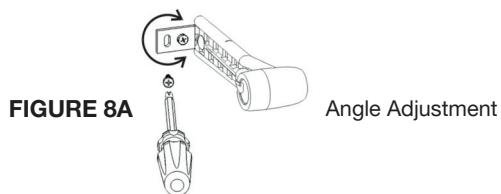

6. Utilize LEDs on photocells for alignment and trouble shooting. Make sure to tighten screws and wing nuts after photocells are aligned.
 - **Red LED (ON), Green LED (ON):** Normal operation
 - **Red LED (ON), Green LED (OFF):** No power. Verify wiring
 - **Red LED (Blinking twice), Green LED (ON):** Bad Alignment, or Obstructed Beam, or Rx defective
 - **Red LED (Blinking twice), Green LED (OFF):** Check power and wiring to Rx, or Rx defective
 - **Red LED (Blinking three times), Green LED (ON):** Rx receiving sunlight (or interference). Install visor or interchange position of transmitter and receiver to reduce sunlight affecting receiver.

To test the photo system: Open the door to full open position. Close the door. When door is closing, obstruct the beam. The door should stop and reverse.

Emergency Manual Operation

The operator is equipped with a quick release disconnect system to manually operate door in case of emergency. This feature should not be used to manually operate a malfunctioning door.

⚠ WARNING ⚠

TO REDUCE THE RISK OF INJURY OR DEATH:

DO NOT ATTEMPT TO USE EMERGENCY DISCONNECT SYSTEM WHILE OPERATOR IS RUNNING.

POWER TO THE OPERATOR SHOULD BE TURNED OFF PRIOR TO OPERATING DOOR MANUALLY.

TO AVOID BEING STRUCK BY DOOR ARM, DO NOT STAND DIRECTLY UNDER THE RELEASE ARM WHEN PULLING THE RELEASE CORD.

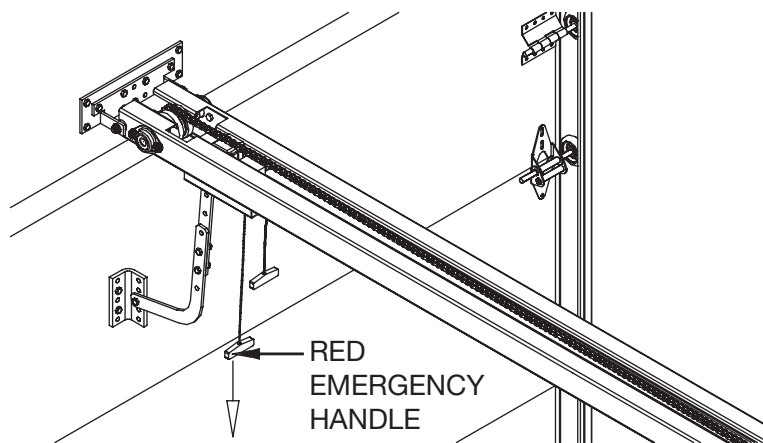

1. Pull once on the emergency disconnect handle (red rope) on trolley carriage downwards to disconnect drive chain arm from carriage and manually operate door.
2. To return to electrical operation, pull once on re-engage handle (green rope) to allow automatic re-engagement of drive chain. Open door manually/or electrically until drive chain bullet re-engages carriage.

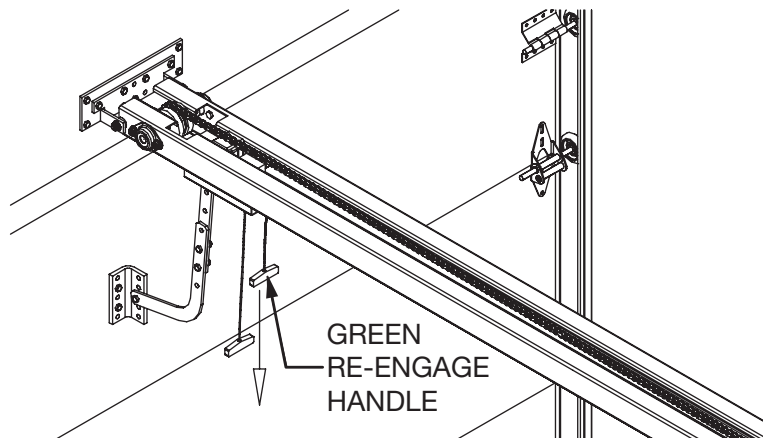

Operator Maintenance

WARNING

TO REDUCE THE RISK OF INJURY OR DEATH:

DO NOT ATTEMPT TO SERVICE THE OPERATOR UNLESS
POWER SUPPLY HAS BEEN DISCONNECTED.

- Inspect manual function of the door every 3-months. Make sure that door runs smoothly. If door does not manually open or close freely, have a qualified service person make repairs. Do not attempt to electrically operate a malfunctioning door.
- Every 3 months:
 1. Verify that door area is kept clean. Remove any obstructions that would prevent proper door operation.
 2. Check for any excessive slack in chains. If chain adjustment is required verify and adjust limit switches, if necessary.
 3. Verify and adjust clutch and brake (Do not lubricate).
 4. Lubricate chains, bearings and limit shaft.
 5. Verify that motor, solenoid and operator runs smoothly and quietly.
- Every 6 months:
 1. Verify tightness of all fasteners and set screws.
 2. Verify that operator is properly secured.
 3. Inspect manual disconnect.
 4. Verify tension and condition of V-belt.
- Every 12 months:
 1. Perform a complete service check.
 2. Verify that inside of control box is clean and that grounding wires, terminations and power terminations do not show signs of corrosion.
 3. Verify tightness of all terminal strip screws and electrical connections.
 4. Verify power supply, voltage of input terminals during operation.
 5. Verify that current consumption of operator corresponds to nameplate information.

Pro-APTC Operator Diagram

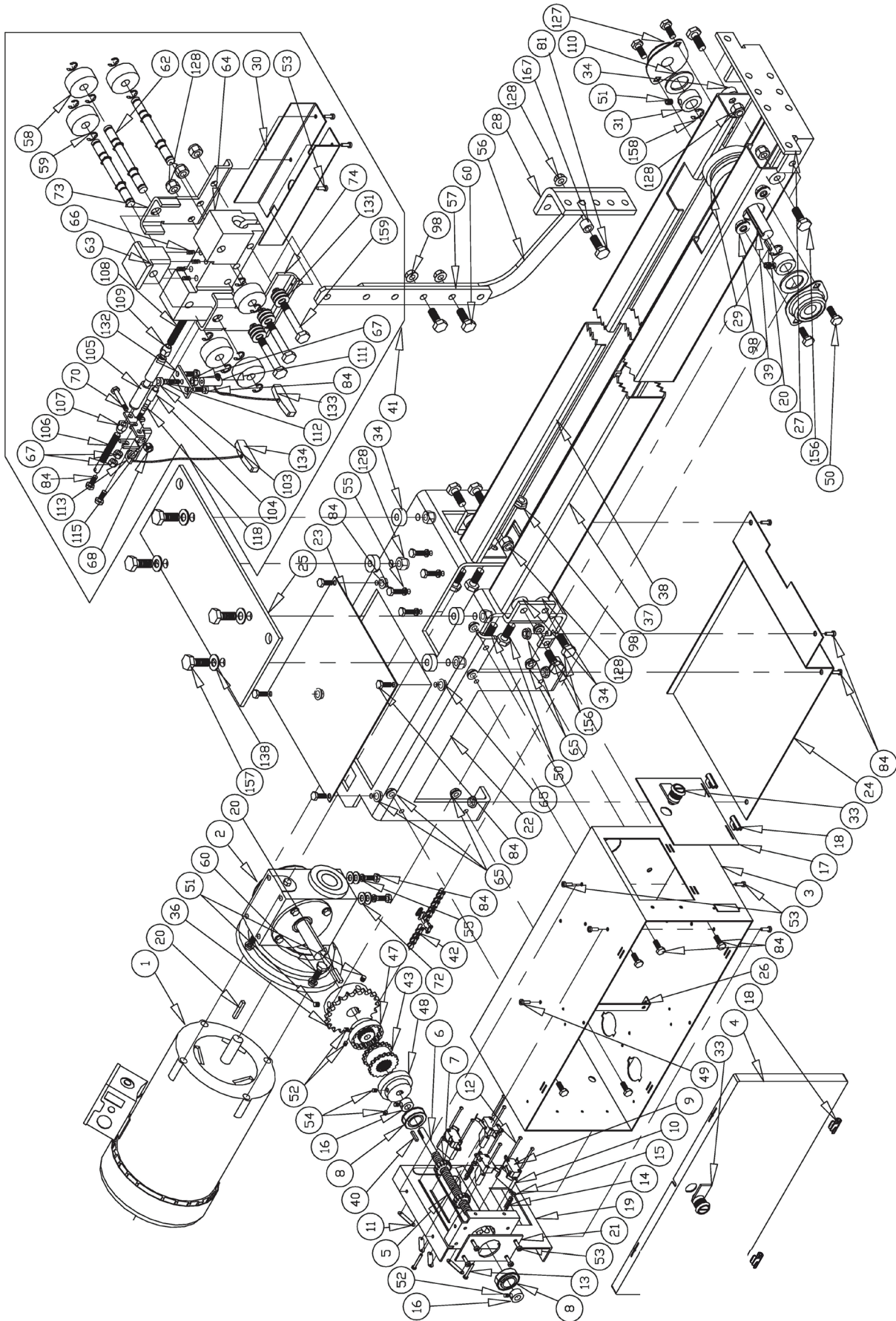

Pro-APTC Operator Parts List

CODE	ARTICLE#	DESCRIPTION	PRO-APTC QUANTITY
**	1	MOTOR	1
MC00050	2	REDUCER SIZE 40 RIGHT ANGLE 40:1	1
MM00411	3	PRO-APTC CONTROL BOX	1
MM00410	4	PRO-APTC CONTROL BOX COVER	1
MM00024	5	CAM PLATE MSI0013	1
ME00074	6	PRO-APTC LIMIT SHAFT 3/8-1/2 UNC COARSE THREAD	1
MG00134	7	PRO-APTC LIMIT CAM 1/2-13 UNC COARSE THREAD	2
MH00096	8	PRECISION FLANGE BEARING 3/8" ID x 1-3/8" OD	2
MK00004	9	LIMIT SWITCH	4
MJ00006	10	LIMIT SWITCH DOUBLE SPACER 3/4" LONG	4
MG00003	11	DOUBLE NUT FOR LIM-SW.	4
MF00003	12	R.H. PHILLIPS MACHINE SCREW 4-40 UNC x 1-1/2"	8
MF00004	13	R.H. PHILLIPS MACHINE SCREW 6-32 UNC x 1"	2
MO00001	14	CAM PLATE COMPRESSION SPRING (.178IDx.032GX.55L)	2
MG00007	15	HEX NYLON LOCK NUT 6-32UNC	2
MH00006	16	COLLAR 3/8 ID	2
MM00420	17	PRO-APTC LIMIT SWITCH COVER	1
MM00046	18	CONTROL BOX HINGE	4
MM00419	19	PRO-APTC CONTROL BOX FRAME	1
ME00018	20	KEYWAY 3/16 SQ. x 1-1/4" LONG	3
MM00412	21	PRO-APTC LIMIT BEARING PLATE	1
MM00408	22	PRO-APTC BASE 1 A	1
MM00408	23	PRO-APTC BASE 1 B	1
MM00421	24	PRO-APTC MOTOR COVER	1
MM00418	25	PRO-APTC MOUNTING PLATE	1
MM00413	26	PRO-APTC LOGIC BOARD SUPPORT U-BRACKET	2
MM00416	27	PRO-APTC RAIL SUPPORT U-BRACKET	1
MM00422	28	PRO-APTC DOOR BRACKET	1
MM00447	29	PRO-APTC IDLER WHEEL	1
MM00441	30	PRO-APTC CARRIAGE COVER	1
MH00008	31	COLLAR 3/4" ID	2
MG00029	32	FLAT WASHER 3/8" ID	
MG00133	33	1/4 TURN LOCK FOR APTC	2
MG00132	34	RUBBER WASHER 3/8" ID x 1/2" THICK	01
MD00418	36	SPROCKET 41B20 x 3/4", 3/16" KW, 2 SS	1
MM00414	37A	PRO-APTC RAIL 10FT RIGHT	1*
MM00415	38A	PRO-APTC RAIL 10FT LEFT	1*
MM00423	37B	PRO-APTC RAIL 12FT RIGHT	1*
MM00424	38B	PRO-APCT RAIL 12FT LEFT	1*
MM00425	37C	PRO-APTC RAIL 14FT RIGHT	1*
MM00426	38C	PRO-APTC RAIL 14FT LEFT	1*
MM00427	37D	PRO-APTC RAIL 16FT RIGHT	1*
MM00428	38D	PRO-APTC RAIL 16FT LEFT	1*
ME00071	39	PRO-APTC IDLER SHAFT	1
ME00078	40	KEYSEAT 1/8" x 1/8" x 3/4" LONG	1
MX00170	41	PRO-APTC COMPLETE CARRIAGE ASSEMBLY	1
MD00029	42	#41 ROLLER CHAIN DRIVE C/W CONN LINK	X FT
MD00422	43	LOVEJOY COUPLER RUBBER	1
MD00413	47	LOVEJOY COUPLER 3/4" ID	1
MD00420	48	LOVEJOY COUPLER 3/8" ID	1

Pro-APTC Operator Parts List

CODE	ARTICLE#	DESCRIPTION	PRO-APTC QUANTITY
MF00045	49	H.H. SLOTTED SELF ROUNDING WASHER HEAD SCREW 8-32 UNF x 3/8"	4
MF00011	50	H.H. BOLT 3/8"-16UNC x 3/4" LONG	8
MQ00008	51	SET SCREW 5/16" -18	4
MQ00009	52	SET SCREW 1/4" -20	4
MF00046	53	H.H. SLOTTED SELF ROUNDING WASHER HEAD SCREW 10-32 UNF x 1/2"	13
MQ00010	54	SET SCREW 10 -24	2
MG00015	55	LOCK WASHER 1/4"	6
MM00032	56	TROLLEY ARM 105 DEGREE (MODIFIED FOR APTC)	1
MM00033	57	TROLLEY EXTENSION ARM (MODIFIED FOR APTC)	1
MM00446	58	PRO-APTC ROLLER	6
•	59	C-CLIP 7/16" (FOR 1/2" SHAFT)	12
MF00019	60	HEX HEAD BOLT 3/8-16UNC x 1" (Full thread)	6
ME00072	62	PRO-APTC CARRIAGE SHAFT	3
MM00434	63	PRO-APTC UHMW CARRIAGE BOTTOM	1
MM00433	64	PRO-APTC UHMW CARRIAGE TOP	1
MG00011	65	RIBBED HEX NUT 1/4-20UNC 14	
MO00026	66	SPRING 0.047" WIRE x 0.57" OD x 1" LONG	4
MG00006	67	HEX NUT 1/4-20UNC	3
MG00009	68	HEX NYLON LOCK NUT 1/4-20UNC	1
MF00029	70	HEX HEAD BOLT 1/4-20UNC x 1-3/4" (partial thread)	1
MG00017	72	1/4" FLAT WASHER	2
MM00435	73	PRO-APTC CARRIAGE SUPPORT LEFT	1
MM00436	74	PRO-APTC CARRIAGE SUPPORT RIGHT	1
MF00020	81	HEX HEAD BOLT 3/8"-16UNC x 1-1/4"	1
MF00007	84	HEX HEAD BOLT 1/4" - 20UNC x 3/4"	20
MG00013	98	RIBBED HEX NUT 3/8" - 16UNC	10
ME00068	103	PRO-APTC DISCONNECT PLUNGER	1
ME00069	104	PRO-APTC CARRIAGE PLUNGER	1
ME00075	105	PRO-APT/APTC CHAIN BULLET	1
MF00119	106	PRO-APT/APTC BULLET TAKE-UP-BOLT RIGHT HAND THREAD	1
MG00136	107	PRO-APT/APTC TAKE-UP-BOLT NUT RIGHT HAND THREAD	1
MF00120	108	PRO-APT/APTC BULLET TAKE-UP-BOLT LEFT HAND THREAD	1
MG00135	109	PRO-APT/APTC TAKE-UP-BOLT NUT LEFT HAND THREAD	1
MG00021	110	FLAT WASHER 7/8" ID x 1-1/8" OD	2
MM00440	111	PRO-APTC CARRIAGE ROPE DISCONNECT RELEASE ROD	1
MO00025	112	SPRING 0.055" WIRE x 0.48" OD x 5/8" LONG 5 TURNS	1
MM00439	113	PRO-APTC CARRIAGE DISCONNECT LEVER	1
MM00438	115	PRO-APTC CARRIAGE FRONT PLATE	1
MO00024	118	SPRING 0.041" WIRE x 3/8" OD x 1.5" LONG 13 TURNS	1
MH00099	127	PRECISION BEARING 3/4" C/W ALUMINUM HOUSING	2
MG00027	128	HEX NYLON LOCK NUT 3/8" -16UNC	14
MG00053	131	FLAT WASHER 3/8" SAE	9
MM00437	132	PRO-APTC CARRIAGE DISCONNECT PLATE	1
*	133	RED LABELED HANDLE AND RED ROPE 18" LONG	1
*	134	GREEN LABELED HANDLE AND GREEN ROPE 14" LONG	1
MF00068	156	HEX HEAD BOLT 3/8" - 16UNC x 1-1/2"	6
MF00087	157	HEX HEAD BOLT 3/8" - 16UNC x 2"	4
MG00122	158	C-CLIP 5/8" (FOR 3/4" SHAFT)	2
MF00121	159	HEX HEAD BOLT 3/8" - 16UNC x 2-1/2"	3
MH00048	167	OILITE FLANGE BUSHING 3/8" ID x 5/8"OD x 1/2" LONG	1

MSL100-110V-3WM-WW 1-Phase Wiring Diagram

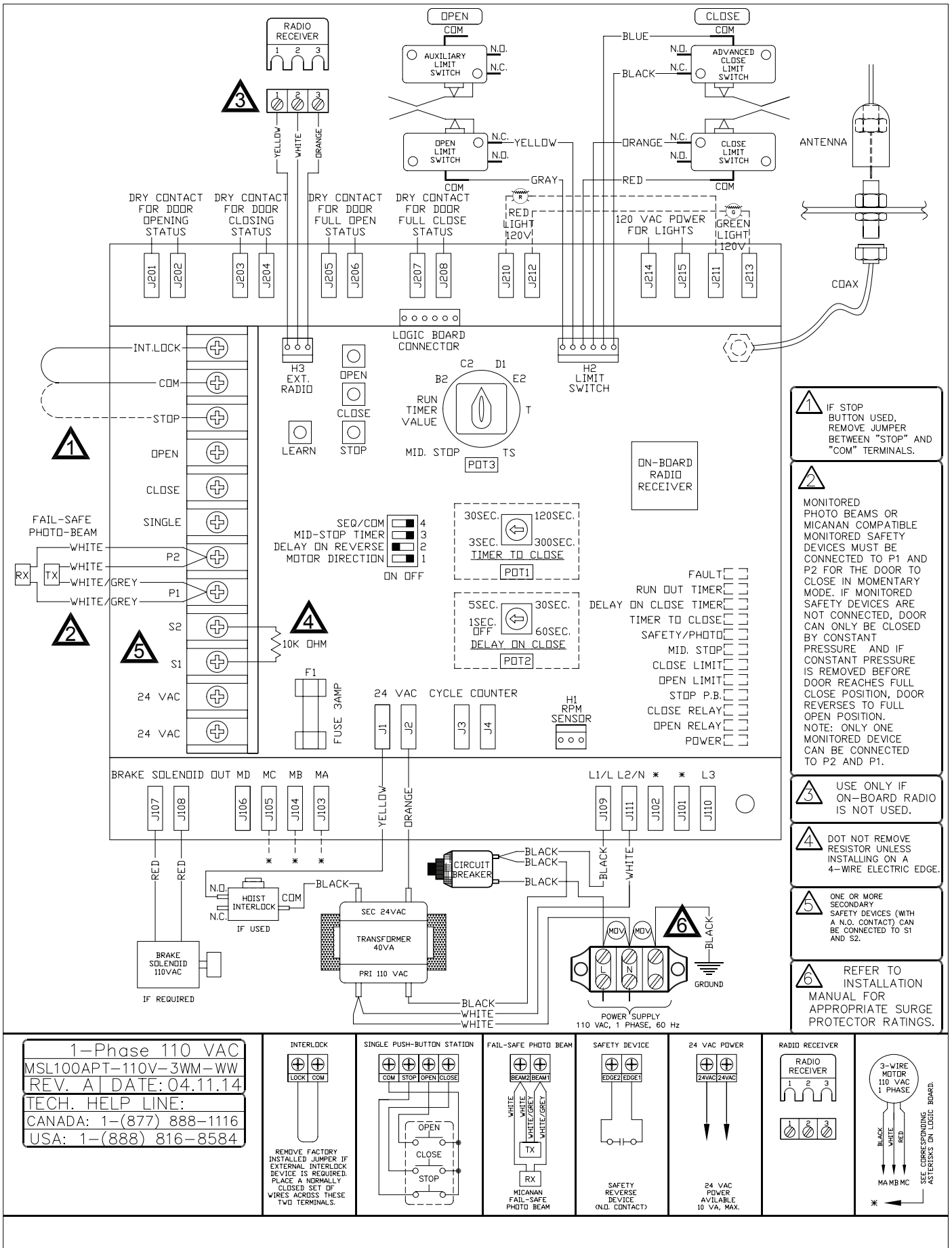

1-Phase 110 VAC
 MSL100APT-110V-3WM-WW
 REV. A | DATE: 04.11.14
 TECH. HELP LINE:
 CANADA: 1-(877) 888-1116
 USA: 1-(888) 816-8584

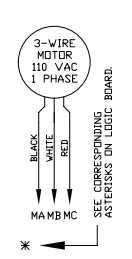
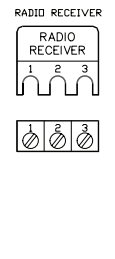
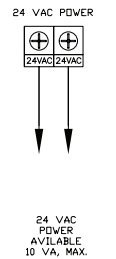
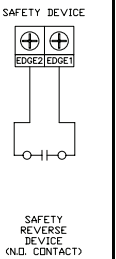
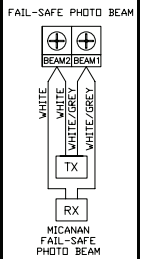
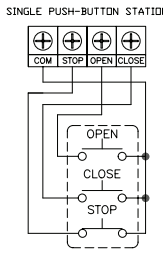
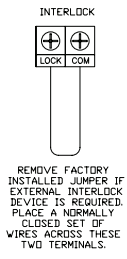

MSL300APT-WW 3-Phase Wiring Diagram

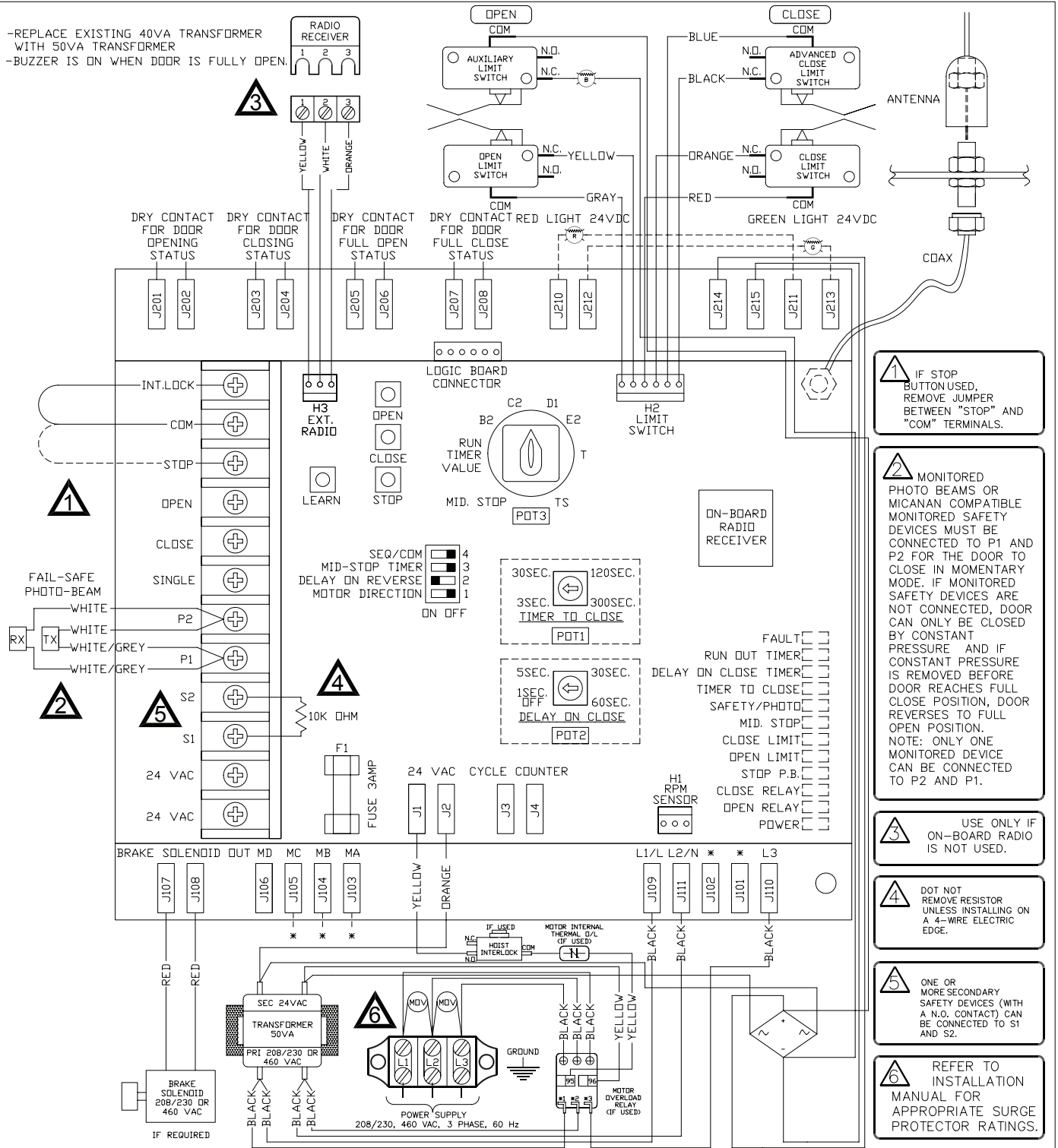

3-Phase Wiring Diagram
 MSL300APT-WW
 REV. B | DATE: 26.01.15
 TECH. HELP LINE:
 CANADA: 1-(877) 888-1116
 USA: 1-(888) 816-8584

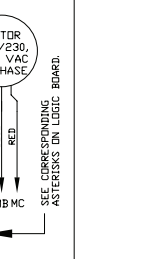
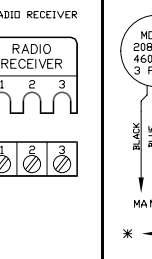
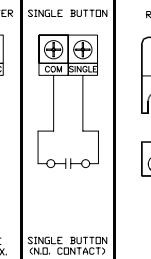
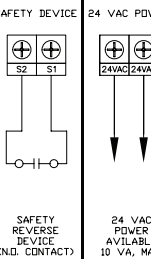
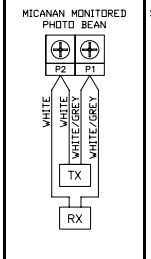
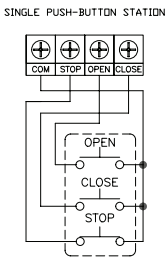
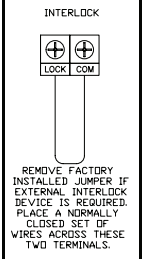

MSLC300APT-WW 3-Phase Wiring Diagram

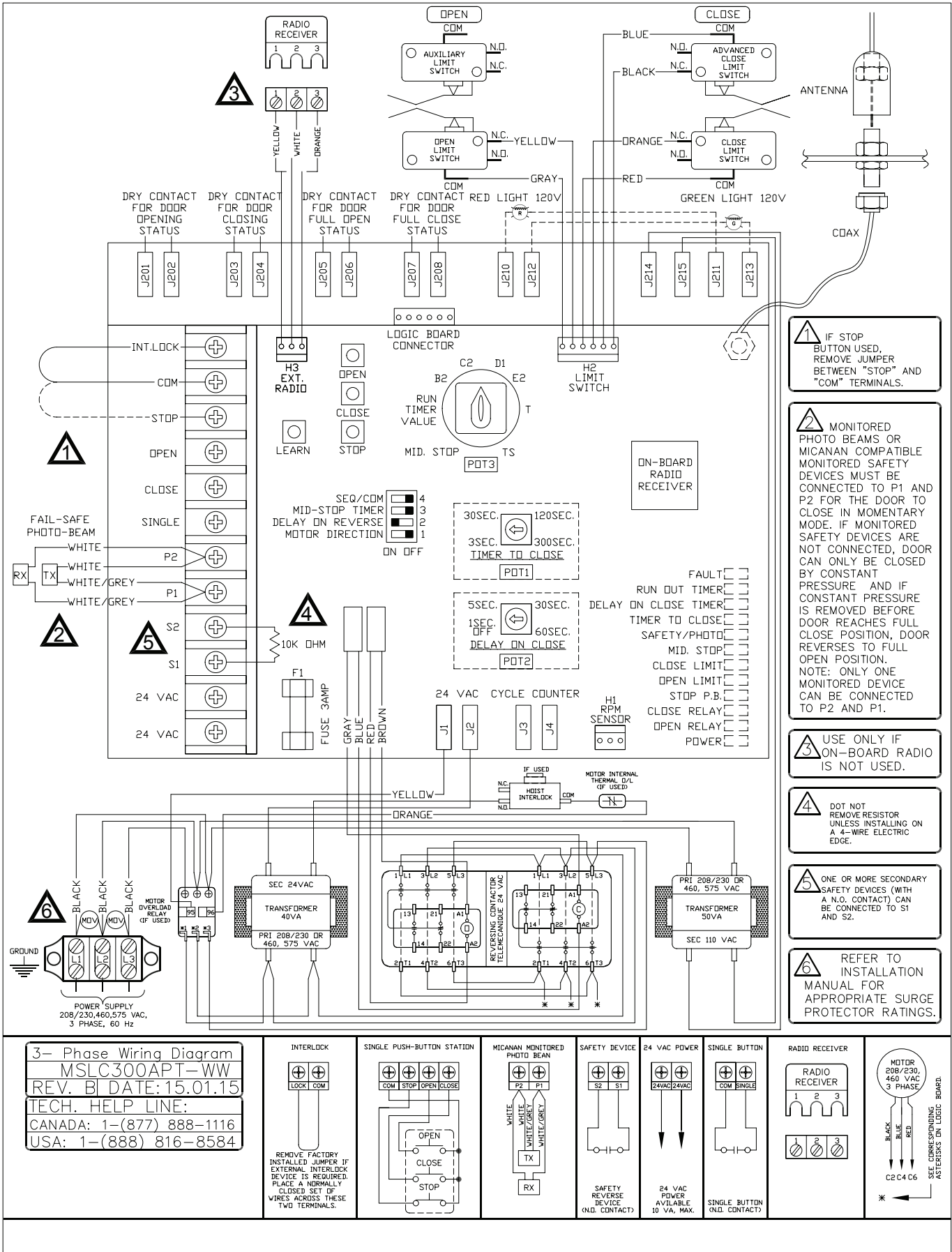

1 IF STOP BUTTON USED, REMOVE JUMPER BETWEEN "STOP" AND "COM" TERMINALS.

2 MONITORED PHOTO BEAMS OR MICANAN COMPATIBLE MONITORED SAFETY DEVICES MUST BE CONNECTED TO P1 AND P2 FOR THE DOOR TO CLOSE IN MOMENTARY MODE. IF MONITORED SAFETY DEVICES ARE NOT CONNECTED, DOOR CAN ONLY BE CLOSED BY CONSTANT PRESSURE AND IF CONSTANT PRESSURE IS REMOVED BEFORE DOOR REACHES FULL CLOSE POSITION, DOOR REVERSES TO FULL OPEN POSITION. NOTE: ONLY ONE MONITORED DEVICE CAN BE CONNECTED TO P2 AND P1.

3 USE ONLY IF ON-BOARD RADIO IS NOT USED.

4 DO NOT REMOVE RESISTOR UNLESS INSTALLING ON A 4-WIRE ELECTRIC EDGE.

5 ONE OR MORE SECONDARY SAFETY DEVICES (WITH A N.O. CONTACT) CAN BE CONNECTED TO S1 AND S2.

6 REFER TO INSTALLATION MANUAL FOR APPROPRIATE SURGE PROTECTOR RATINGS.

3- Phase Wiring Diagram
 MSLC300APT-WW
 REV. B1 DATE: 15.01.15
 TECH. HELP LINE:
 CANADA: 1-(877) 888-1116
 USA: 1-(888) 816-8584

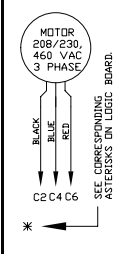
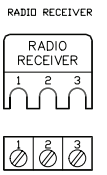
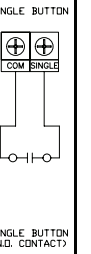
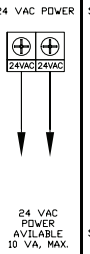
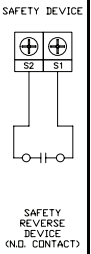
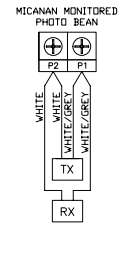
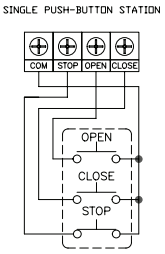
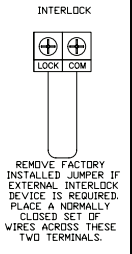

Technical Support:
877-888-1116

Technical Support Hours:
M – F, 8:00 a.m. – 6:00 p.m. ET

Nice North America
c/o Customer Service
5919 Sea Otter Place, Suite 100
Carlsbad, CA 92010



Niceforyou.com

©2024 Nice North America LLC.
All rights reserved.