

# PRO-HBH ARCHITECTURAL SHOP DRAWING

Date: \_\_\_\_\_

Page: \_\_\_\_\_ of \_\_\_\_\_

Drawing No.: \_\_\_\_\_

Architect/ Engineer: \_\_\_\_\_

Contractor: \_\_\_\_\_

Customer: \_\_\_\_\_

Number of Operators: \_\_\_\_\_

Horsepower: \_\_\_\_\_

Volts: \_\_\_\_\_

Phase: \_\_\_\_\_

Hertz: \_\_\_\_\_

Type of Door: \_\_\_\_\_

Door Width/ Height: \_\_\_\_\_ W x \_\_\_\_\_ H

Operator Nema Rating: \_\_\_\_\_

OPEN/ CLOSE/ STOP Control Stations: \_\_\_\_\_

## FULL LOAD AMP RATING CHART (AMPS)

VOLTAGE	1/3 HP	1/2 HP	3/4 HP	1 HP
115V 1-Φ, 60 HZ	7.9	8.5	11.6	14.2
230V 1-Φ, 60 HZ	3.9	4.2	6.0	7.2
230V 1-Φ, 50 HZ	3.1	3.1	5.6	
208/230V 3-Φ, 60 HZ	2.1	2.1	2.8	3.5
380V 3-Φ, 50 HZ	1.1	1.1	1.4	2.2
460V 3-Φ, 60 HZ	1.1	1.1	1.5	1.8
575V 3-Φ, 60 HZ	1.0	1.0	1.2	1.5

Control Wiring Option: \_\_\_\_\_

- A** Relay Logic w/ interface module (monitored reversing device supplied)
- B** Smart 10.0 logic board (monitored reversing devices supplied)
- C** Relay Logic (not available in US or other areas where UL325 is mandated)

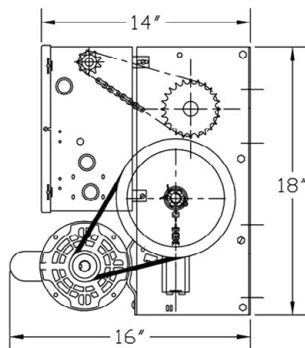
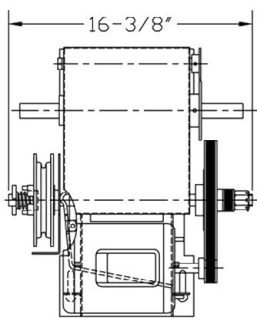

WALL MOUNT

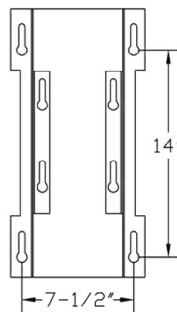

BRACKET MOUNT

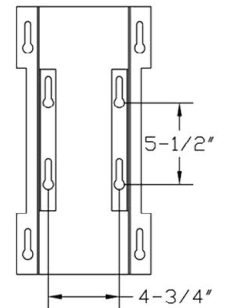

## ADDITIONAL EQUIPMENT OR OPTIONS

---



---



---

