



LIMITED DUTY CIRCUIT BOARD START-UP INSTRUCTIONS (WITHOUT MONITORED SAFETY DEVICE)

WARNING: COMPARE AVAILABLE POWER SUPPLY VOLTAGE TO OPERATOR NAMEPLATE PRIOR TO ELECTRICAL CONNECTION. FAILURE TO CONNECT APPROPRIATE POWER SUPPLY VOLTAGE MAY CAUSE SERIOUS DAMAGE TO THE OPERATOR

IMPORTANT: READ THESE INSTRUCTIONS PRIOR TO MAKING ANY POWER CONNECTIONS

Note: The operator is shipped from the factory in the C2 mode (constant pressure close and momentary open). The operator should remain in this mode until all connections and limit switch adjustments are completed.

POWER WIRING INSTRUCTIONS:

Connect primary power supply directly to the separate power terminal strip supplied using any of the 1-1/8" (2.85 cm) diameter holes provided on control box. **Do not connect power supply directly to the circuit board.**

Connect 110V single phase power supply to terminals L (line) and N (neutral) on three-pole power terminal strip.

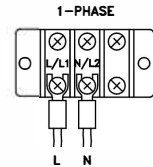

ON BOARD O/C/S PBS INSTRUCTIONS:

On-board Open, Close and Stop buttons are provided directly on the board for installation and troubleshooting purposes. In order to operate unit by on-board Open, Close, Stop buttons, the factory installed jumper (#1) between the COM and STOP terminals on the terminal strip must remain connected.

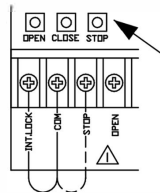

MOTOR DIRECTION VERIFICATION:

Make sure the mode of operation is selected to C2. After electrical power connections are made, manually move door to mid-position. Using the on-board buttons press the "Open" button for several seconds and then press the "Stop" button. If door did not move in correct direction (or if limit cams not moving in correct direction towards the open limit switch) see below:

The operators leave the factory with correct motor and limit shaft direction according to standard door installations. However, for special fire door, through wall mounting or other special door applications, the motor direction and limit switch direction may need to be reversed. To reverse the motor rotation, interchange red and yellow wires on the capacitor and interchange the wires on open and close limits. Disconnect the 2 wires from the advanced closed limit switch and re-connect to the auxiliary limit switch provided.

Note: Ensure that when the on-board open button is depressed and the door moves in the correct open direction that activation of the open limit switch stops the door.

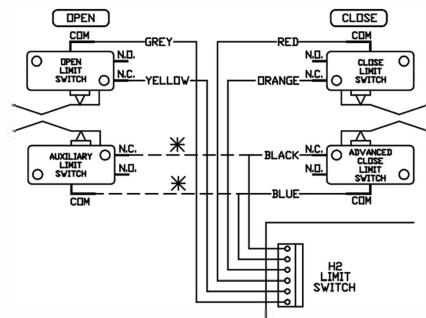

LIMIT SWITCH ADJUSTMENTS:

Once the motor rotation and limit cam direction have been verified, adjust the limit cam settings. Refer to operator installation manual for complete limit switch adjustment instructions.

CONNECTION OF EXTERNAL O/C/S PBS:

Connect O/C/S PBS as shown in diagram. **Note:** Jumper #1 must be removed after the external O/C/S PBS has been installed.

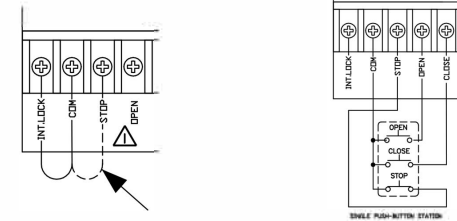

CONNECTION OF REVERSING DEVICE(S)

The logic board has provisions to connect one or more safety device(s)

A standard 2-wire safety edge, non-monitored photo beams or any other non-monitored reversing devices with a N.O contact can be connected to terminals S1 and S2 as a non-monitored safety device.

Note: More than one non-monitored safety device can be connected to terminals S1 and S2.

Important: Do not remove the resistor that is factory installed across terminals S1 and S2 unless installing a 4-wire electric edge.

4-wire electric edge:

A standard 4-wire electric edge can be connected across S1 and S2 terminals as a safety device.

Remove the factory installed resistor across terminals S1 and S2 when using a 4-wire electric edge



CONNECTION OF EXTERNAL SINGLE-BUTTON DEVICE

Connect an external single-button as shown in diagram. Please refer to "Modes of operation" for the functionality of single-button.

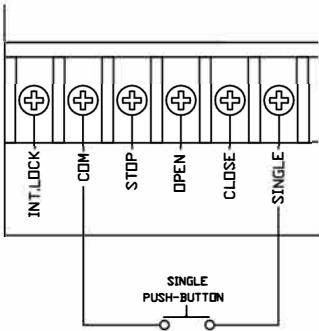

MODES OF OPERATION

All operators leave the factory with the jumper on C2. Please read all modes of operation and determine which operational mode is desired

B2: (Momentary on open and close)

- Open Button: Momentary activation opens the door. When door is closing, momentary activation reverses the door (OPEN OVERRIDE).
- Close button: Momentary on close.
- Stop button: Momentary activation stops the door.
- Single button device and external radio control: Open/Close/Reverse
- Safety Devices: When door is closing, momentary activation reverses the door.
- Timer to close: N/A

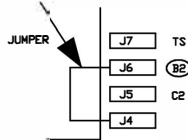

C2 (Momentary open, constant pressure close)

- Open Button: Momentary activation opens the door. When door is closing, momentary activation reverses the door (OPEN OVERRIDE).
- Close button: Constant pressure on close. Door will stop when button is released
- Stop button: Momentary activation stops the door.
- Single button device: Open/Constant pressure close/Stop
- External radio receiver: momentary activation opens the door (cannot close the door).
- Safety Devices: When door is closing, momentary activation reverses the door.
- Timer to close: N/A

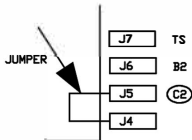

TS: (Momentary on open and close, timer to close secure, STOP BUTTON DISABLES TIMER)

- Open Button: Momentary activation opens the door. When door is closing, momentary activation reverses the door. Momentary contact at full open position re-activates the timer if timer has been disabled previously by stop button.
- Close button: Momentary on close.
- Stop button: If door is opening or closing, momentary activation stops the door. Momentary activation while timer is counting at full open de-activates the timer.
- Single button and external radio: open/reverse/refresh timer.
- Safety Devices: When door is closing, momentary activation reverses the door. Momentary activation when door is at full open refreshes the timer to close.
- Timer to close: Closes the door from full open. Momentary activation of stop button will de-activate the timer. Timer resumes its normal operation upon momentary activation of open push button or once the close cycle is completed.

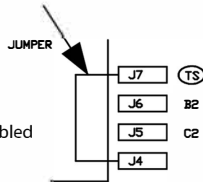

General Information: Auxiliary device may be installed to edge terminals, open or close button terminals, and single button terminals providing that they are of the NORMALLY OPEN DRY CONTACT TYPE.

Timer to close Setup:

Timer to close is enabled only in TS mode of operation. There are 3 LED lights on the board to indicate the timer to close value. Default setting of timer to close is 3 seconds. To modify this value, press "TIMER PROGRAM" button until desired value is reached. The LED status changes when the "TIMER PROGRAM" button is pressed each time. The following chart correlates the LED lights status to the timer to close value.

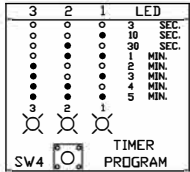

STATUS LED:

LED	STATUS	CAUSE
Fault	ON	-Safety devices not connected or functioning properly. - Safety devices are activated.
Power	ON	- 24 VAC power to logic board is ON.